

# KONINKLIJKE LANDMACHT

2 DL 002083

---

DETAILLIJST

Basisboek, t.b.v. Y-4222 serie  
(Alle uitvoeringen)

PROJECTNUMMER : 002083



DIRECTIE MATERIEEL KL  
AFDELING WIELVOERTUIGEN  
EN GENIEMATERIAAL

aangebrachte opgave van wijziging

nummer	nummer	nummer	nummer	nummer	nummer

Hierbij vervalt:

d.d.

Vastgesteld door het hoofd van de Afdeling Wielvoertuigen en Geniematerieel van de Directie Materieel KL, d.d. 05-09-1989.

Y-CHE.ME

## Overzicht Vau's 40 kN 4x4 DAF Y-4442

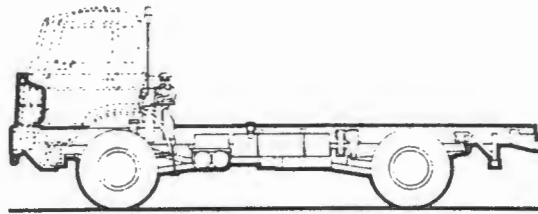

Proj. nr. 2083: Basisgedeelte voor alle uitvoeringen

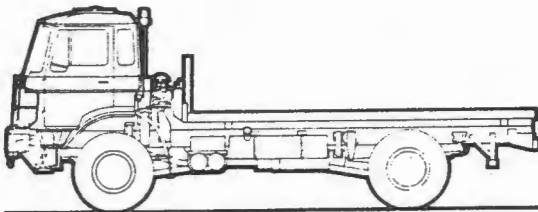

Proj. nr. 2084 : YAS-4442 (Sheltervervoer)  
NSN 2320-17-053-8271

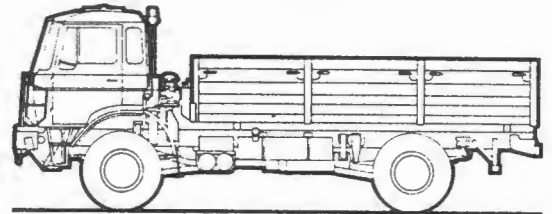

Proj. nr. 2091 : YAJ-4442 (Jerrycan-vervoer; ADR/VLG)  
NSN 2320-17-101-7944

Proj. nr. 2090 : YAO-4442 (Opleidingsvoertuig)  
NSN 2320-17-101-8084

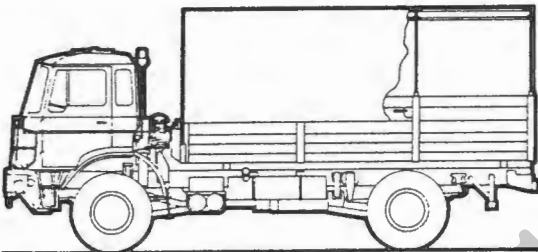

Proj. nr. 2089 : YAI-4442 (Inbouw)  
NSN 2320-17-101-7943

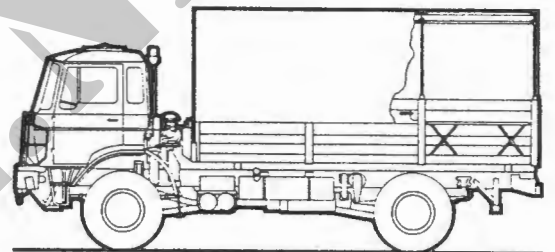

Proj. nr. 2088 : YAD-4442 (Algemene dienst vtg.)  
NSN 2320-17-101-8780

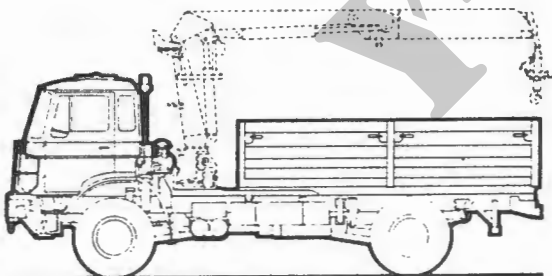

Proj. nr. 2087 : YAK-4442 (vtg. met autolaadkraan)  
NSN 2320-17-053-8270

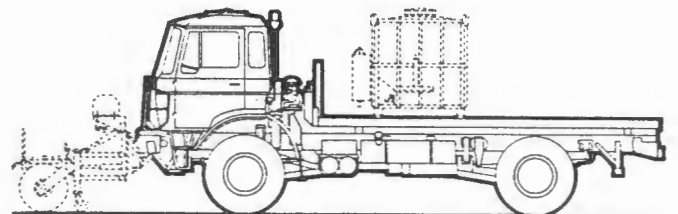

Proj. nr. 2092 : YAV-4442 (vtg. voor veeginstallatie)  
NSN 2320-17-102-4747

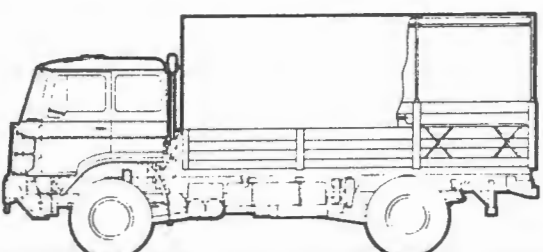

Proj. nr. 2086 : YAL-4442 (Lesvoertuig)  
NSN 2320-17-053-8269

Y-CHE.ME

## TOELICHTING OP DE DETAILLIJST

### 1. ALGEMEEN

Een detaillijst bestaat uit : a. - tekst  
b. - afbeeldingen

ad a. De tekst bestaat uit:  
(1) de inhoudsopgave  
(2) de artikelgegevens

ad b. Iedere afbeelding (MOS) wordt geïdentificeerd door een MOS-nummer bestaande uit 2 groepen van 4 posities gescheiden door een koppelteken. De 1e groep van 4 posities geeft de hoofd- en subgroep aan van de samenstelling waar de afbeelding betrekking op heeft. De 2e groep van 4 posities geeft het afbeeldingsnummer van de desbetreffende MOS binnen voornoemde hoofd-/subgroep.

N.B. Wanneer in de detaillijst geen 1DL is opgenomen, kan deze door het 2e t/m het 5e echelon apart worden aangevraagd.

### 2. HET GEBRUIK VAN DE DETAILLIJST

Stel u heeft gegevens nodig van een artikel; hiertoe gaat u als volgt te werk:

- Zoek in de inhoudsopgave de naam van het samengestelde deel op waarvan het artikel deel uitmaakt en u vindt het daarbij behorende MOS-nummer
- Zoek in het plaatdeel met het gevonden MOS-nummer de gewenste afbeelding op
- Zoek in de afbeelding het artikel op en u vindt het daarbij behorende figuurnummer
- Zoek in de tekst het deel met hetzelfde MOS-nummer op
- Zoek in de kolom "FIG NR" het figuurnummer op wat u gevonden hebt op de afbeelding.

U beschikt nu over de volgende artikelgegevens:

- het NATO-stocknummer (NSN)
- het fabrikantencodenummer (FCN)
- het fabrieksartikelnummer (FAC)
- een artikelomschrijving
- het aantal gemonteerd
- het echelon
- evt. opmerkingen

### 3. OVERIGE INFORMATIE

- a. Aan de boven- en onderzijde van het tekstblad is de benaming van de afbeelding vermeld waarop het tekstblad betrekking heeft. Indien het figuurnummer wordt gevolgd door een letter (bijv. 3A, 6A etc.) is er sprake van een niet afgebeeld artikel of van een op een later tijdstip tussengevoegd artikel. Als in de kolom "Natostocknummer" geen natostocknummer is vermeld betreft het een artikel dat niet aangevraagd kan worden.
- b. In de kolom "echelon" is het laagste echelon aangegeven waarop de onderhoudswerkzaamheden mogen worden verricht of waardoor het artikel mag worden aangevraagd.

**Y-CHE.ME**

- c. Het aantal genoemd in de kolom "Aantal gemonteerd" heeft betrekking op het aantal gemonteerd binnen het naasthoger samengestelde artikel.
- d. Indien in de kolom "Opmerkingen" geen andere rekeneenheid is aangegeven is de rekeneenheid van het artikel "stuk" (EA).  
Voor overige aanduidingen in deze kolom zie de lijst van afkortingen.

4. WIJZIGINGEN

Wijzigen van de detaillijst geschiedt door het toezenden van vervangingsbladen en zonodig een gewijzigde inhoudsopgave.

Op ieder tekstblad is vermeld op welke datum de desbetreffende bladzijde tot stand is gekomen. Bij vervanging van de bladzijde wordt de verwerkingsdatum van het vervangende blad vermeld. De gewijzigde c.q. toegevoegde regels zijn op de vervangingsbladen gemerkt met een \* in de kolom opmerkingen.

KCH.E.M.

**Y-CHE.ME**

## LIJST VAN AFKORTINGEN

In deze detaillijst kunnen de navolgende afkortingen voorkomen:

Tabel opmerkingen in de detaillijst (OPM)

Code	Betekenis
DR	- Het artikel is voor het 2e tot en met het 5e echelon een directe ruil artikel.
EI	- Het artikel moet worden ingeleverd op grond van zijn exploitatie inhoud.
HB	- Het artikel is beperkt houdbaar.
IM	- Bij het bestellen van dit artikel dient een minimum stuklengte te worden opgegeven.
KEW	- Het artikel moet worden ingeleverd op grond van de kernenergie wet.
MW	- Het artikel moet worden ingeleverd op grond van de milieuwet.
OBA	- Het artikel heeft een BEVO-waarde van 02 en is dus een oorlogsbevoorrading artikel.
OW	- Het artikel moet worden ingeleverd op grond van de opiumwet.
R	- Het artikel komt voor reparatie in aanmerking, of het artikel moet worden uitgesplitst in componenten. Het artikel is geen directe ruil artikel.
Zie VS	
2-100	- Op dit artikel zijn verdere materieel technische publicaties van kracht, zie hiervoor het VS 2-100, de index van van kracht zijnde materieel technische publikaties.
Spatie-	Geen van bovenstaande opmerkingen en het artikel wordt per stuk verstrekt.
**	- De verstrekkingseenheid van dit artikel is niet ingevuld.

Opmerking: Alle overige afkortingen die in de KOLOM OPMERKINGEN staan verwijzen verder naar de tabel verstrekkingseenheid.

**Y-CHE.ME**

Tabel verstrekkigseenheid (VRSE)

Code	Betekenis	Code	Betekenis
AA	250	DI	dispenser
AM	ampul	DX	stel kaarten
AT	assortiment	DL	deciliter
AV	25	DM	drachme, US (3,888 g)
AX	20	DR	trommel, drum
AY	samenstel	DW	pennyweight (1,555 g)
BA	kluwen	DZ	dozijn (12 stuks)
BC	blok	EA	stuks
BD	bundel, A	EN	envelop, map
BE	baal	FL	flacon, fles
BF	board foot (0,00236 m3)	FO	font
BG	zak, tas	FT	voet (30,48 cm)
BH	bundel, bos	GB	gallon, ENG (4,546 l)
BI	briket	GG	12 gros (1728 stuks)
BK	boek	GI	1/4 pint, US (0,1183 l)
BL	vat, ton	GL	gallon, US (3,785 l)
BN	bundel, V	GM	gram
BO	rol (stof, papier)	GN	grein (0,0648 g)
BR	staaf	GP	groep
BT	fles	GR	gros (144 stuks)
BU	schepel, US (35,24 l)	GS	glazen pot
BX	doos(je)	HD	100
CA	huls	HE	stuks (vee)
CB	mandfles	HF	100 voet (30,48 m)
CC	kubieke centimeter (cm3)	HG	half gros (72 stuks)
CD	kaart, D, kubieke yard, A (0,7646 m3)	HH	okshoofd (2,385 h)
CE	kegel	HI	120 acres
CF	kubieke voet (0,02832 m3)	HK	streng (768,1 m)
CG	centigram	HP	100 pound (45,36 kg)
CH	kist	HS	100 vierkante voet
CI	kubieke inch (16,39 cm3)	HW	centenaar (CW)
CK	stuk (zeep)	HY	100 yard (91,4 m)
CL	klos	IG	staa
CM	centimeter	II	2
CN	kan, bus	IN	inch (2,54 cm)
CO	container	IV	4
CP	capsule	JG	kruik
CQ	kubieke millimeter	JR	pot, stopfles
CR	krat	KD	vadem (3,625 m3)
CS	kist	KE	vaatje
CT	kartonnen doos	KG	kilogram
CU	kubieke yard (0,7646 m3)	KK	66 voet, US (30,48 m)
CV	kubieke decimeter	KM	kilometer (1000 m)
CW	1000 kubieke meter	KR	karaat (0,2 g)
CX	bus, blikken kan	KS	vat, ton
CY	cilinder, drukfles	KT	gereedschapskist
CZ	kubieke meter (1000 l)	LB	pound, ENG (0,4536 kg)
DC	decagram	LF	streckende voet
DE	decimeter	LG	lengte
DG	decigram	LI	licht
DH	half dozijn (6 stuks)	LK	schakel (20,12 cm)
		LL	50

**Y-CHE.ME**

Code	Betekenis	Code	Betekenis
LN	long ton (1016 kg)	RO	wals, rol, A staaf, D
LR	liter	SB	metalen plaat
LT	partij	SC	onderdeel
LY	streckende yard	SD	skid
MA	magazijn	SE	set
MB	1000 vaten	SF	vierkante voet, NL (900 cm <sup>2</sup> )
ME	rantsoen		vierkante voet, SI (929 cm <sup>2</sup> )
MF	1000 voet (304,80 m)	SG	canule
MG	milligram	SH	vel
MI	mijl (1609 m)	SI	vierkant inch (6,452 cm <sup>2</sup> )
ML	milliliter	SK	120 yard
MM	millimeter	SL	spoel
MR	meter	SN	huid
MX	1000	SO	projectiel
NT	net ton (952,6 kg)	SP	strook
OT	uitrusting	SQ	9,29 meter
OZ	ons, ENG (28,35 g)	SR	beker
PA	blad	SS	108 kubieke voet (3,059 m <sup>3</sup> )
PC	stuk	ST	staaf
PD	schrijfblok	SU	garnituur
PE	2 gallon, US (8810 l)	SV	mof, sok
PF	paneel	SW	subscription
PG	pakje	SY	vierkante yard (0,8361 m <sup>2</sup> )
PH	$\frac{1}{2}$ pond, ENG (226,5 g)	SZ	stock
PK	pak	TB	kuip, tobbe
PL	emmer	TL	10 vaten
PM	plaat	TN	ton (1000 kg)
PN	verpakking	TO	troy ounce (31,10 g)
PO	zak	TP	band
PR	paar	TR	bakje
PT	pint, 1/8 gallon, US (0,4732 l)	TS	short ton (907,2 kg)
PY	pyramide	TT	tablet, plaat
PZ	pakje	TU	tube, koker
QC	vierkante centimeter	UN	eenheid
QD	vierkante decimeter	US	USP eenheid
QI	quard, ENG (1,136 l)	VC	500
QL	vierkante millimeter	VI	fiool
QM	vierkante meter	VM	5000
QR	boek, papier (24 vel)	VO	boekdeel
QT	quard, droge stof, US (1,101 l)	VX	5
RA	rantsoen	WF	ouwel
RD	schot	WG	wijngallon (3,7553 l)
RE	haspel, spoel, D	XL	centiliter
RL	haspel, spoel, A wals, rol, D	XV	15
RM	riem	XX	10
RN	strook	YD	yard

**Y-CHE.ME**

I N H O U D S O P G A V E  
-----

01	MOTOR
0102	
0102-0001	CILINDERBLOK
0102-0004	ZIJDEKSELS
0106	
0106-0001	KLEPPEN, -VEREN, -STOTERS
0107	
0107-0001	SMEERORGANEN ( INW. )
0108	
0108-0002	OLIEKOELER
0108-0003	OLIELEID. TURBO-COMPRESSOR
0110	
0110-0001	MOTORREM MET BEDIENING
0111	
0111-0001	VENTILATOR
0111-0002	SNAARSCHIJVEN EN RIEMEN
03	BRANDSTOF SYSTEEM
0301	
0301-0001	BRANDSTOFTANK
0301-0002	BRANDSTOFLEIDINGEN
0301-0003	BRANDSTOFFILTERS
0302	
0302-0002	INSPUITLEIDINGEN
0302-0003	BRANDSTOF-EN LEKLEIDINGEN

I N H O U D S O P G A V E

0303		
0303-0003	OPVOERPOMP	
0303-0004	VULDRUKREGELAAR	
0304		
0304-0001	GASBEDIENING, -STOPBEDIENING	
05	KOELSYSTEEM	
0501		
0501-0001	RADIATEUR, EXPANSIETANK	
0504		
0504-0001	KOELWATERPOMP KPL	
0504-0002	THERMOSTATEN	
0505		
0505-0001	WINDTUNNEL, MANCHET	
06	ELEKTRISCHE INSTALLATIE	
0601		
0601-0001	DYNAMO	
0603		
0603-0001	BATTERIJHOUDER	
0603-0002	BATTERIJKABELS	
0604		
0604-0001	ELEC. CENTRAALKAST	
0604-0003	CONTACTDOZEN OP LAADBAK	
0604-0004	EL. ZEKERINGKAST IN CABINE	
0605		
2	0605-0002	SNELHEIDSMETER TOERENTELLER

I N H O U D S O P G A V E

0606	
0606-0001	VERLICHTING
0606-0002	VERLICHTING VERDUISTERIJ
0608	
0608-0002	EL.LEIDINGBOMEN LAADBAK
0609	
0609-0001	STARTMOTOR
0610	
0610-0001	CLAXON
07	KOPPELING EN TRANSMISSIE
0702	
0702-0004	BEDIENINGSCILINDER
0703	
0703-0002	HUIS VERSNELINGSBAK
08	AANDRIJFAS/EINDAANDRIJVING
0801	
0801-0002	HUIS TUSSENBAK
0803	
0803-0002	SCHAKELMECHANISME(UITW)
0803-0004	VENTIEL,BEDIENING TUSSENBAK
0804	
0804-0001	TUSSENASSEN

I N H O U D S O P G A V E

0805

0805-0002 VOORASLICHAAM  
0805-0003 DIFF. VOORAS

0806

0806-0002 ACHTERASLICHAAM  
0806-0003 DIFF. ACHTERAS  
0806-0004 AANDRIJFASSEN IN ACHTERAS

09  
0901 LOOPWERK

0901-0001 FUSEE-, STUUR-, SPOORSTANGARMEN

0902

0902-0001 NAAF EN REMTROMMEL VOORAS  
0902-0002 NAAF EN REMTROMMEL ACHTERAS  
0902-0003 REMTROMMELASSET, VOORAS, DR  
0902-0004 REMTROMMELASSET, ACHTERAS, DR

0904

0904-0001 BANDEN EN VELGEN

10  
1001 VERING EN DEMPING

1001-0001 VOORVEER EN OPHANGING  
1001-0002 SCHOKBREKERS VOORAS

1002

1002-0001 ACHTERVEER EN OPHANGING  
1002-0002 SCHOKBREKERS ACHTERAS

12  
1201 REMSYSTEEM

4 1201-0001 REMPEDAAL MET STANGEN

I N H O U D S O P G A V E  
-----

1201-0002	VOETREMKLEP
1201-0006	REMCILINDERS VOORAS (ONDERD.)
1201-0007	REMCYLINDERS ACHTERAS
1201-0008	DRUKREGELAAR
1201-0009	LUCHTDROGER
1201-0010	RELAISVENTIEL
1201-0012	REACTIEVENTIEL
1201-0013	LASTAFH. REMREGELING
1201-0014	4-KRINGS VEILIGH. VENTIEL
1201-0015	TERUGSLAGKLEP
1201-0018	MEETAANSLUITING
1202	
1202-0001	LUCHTKETELS
1202-0002	REMLEIDINGEN, -SIANGEN
1202-0003	KOELLEIDING
1202-0004	REMLEIDINGEN ACHTERAS
1202-0005	LEIDINGKOPPELINGEN
1203	
1203-0001	COMPRESSOR
1204	
1204-0001	REMSCHOEN EN NOKAS VOOR
1204-0003	REMSCHOEN EN NOKAS ACHTER
1206	
1206-0001	BEDIENINGSKLEP VOLGW.
1206-0003	KOPPELINGSKOPPEN VOLGWAGEN
1206-0004	BUFFER RESERVOIR
14	
1401	STUURSYSTEEM
1401-0001	STUURKOLOM EN STUURWIEL

I N H O U D S O P G A V E  
-----

1401-0002	STUURSTANG
1401-0003	SPOORSTANG
1403	
1403-0002	HYDRAULISCHE STUURLEIDINGEN
1403-0003	HYDR. STUURPOMPTANK
18	CHASSIS/CARROSSERIE
1802	
1802-0005	PORTIEREN
1802-0006	GRILLE
1803	
1803-0002	SPATSCHERMEN ACHTER
1805	
1805-0001	STOEL, BESTUURDER
1805-0007	AFDEKMIDDELEN
1805-0008	INTERIEUR
1807	
1807-0001	OPBERGKAST DEKZEIL
1807-0002	PIONIERREK
1809	
1809-0001	BUMPER
1809-0002	BESCHERMROOSTER RADIATEUR
1809-0003	TAKKENSCHERM
1810	
1810-0001	TREKHAAK
1810-0002	SLEEPOGEN

PROJECTNUMMER 002083 VAU, 40KN, 4X4, Y4442 BASISUITV. BLAD: 7

I N H O U D S O P G A V E

1811	
1811-0001	RESERVEWIELDRAGER
19	OPBOUW
1902	
1902-0001	STOOTBALK+BUFFERS
25	LUCHTCONDITIONERINGS-SYSTEEM
2501	
2501-0001	VERWARMINGSKACHEL

V-CHE.ML

**YCHIE.ME**

**Y-CHE.ME**

PROJECTNUMMER: 002083

MOSNUMMER : 0102-0001

CILINDERBLOK

DATUM 871102

BLAD 1 VAN 1 BLADEN

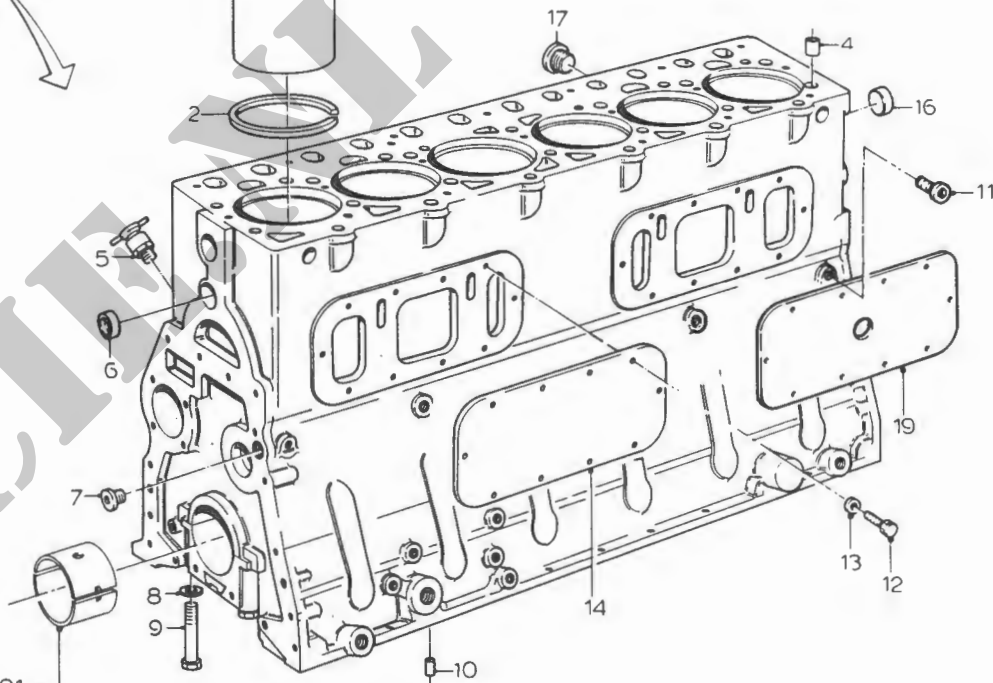
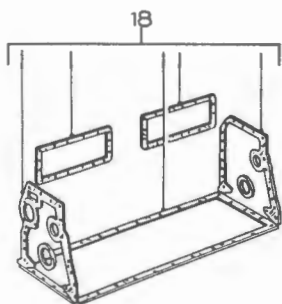
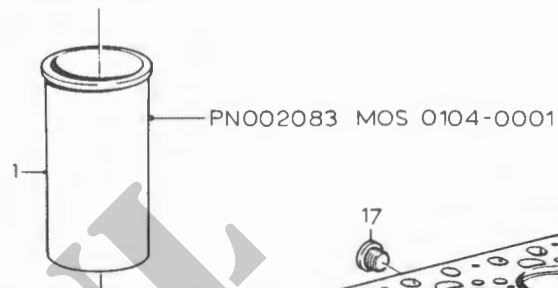
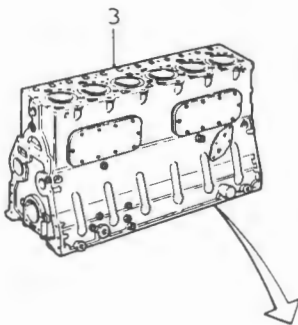
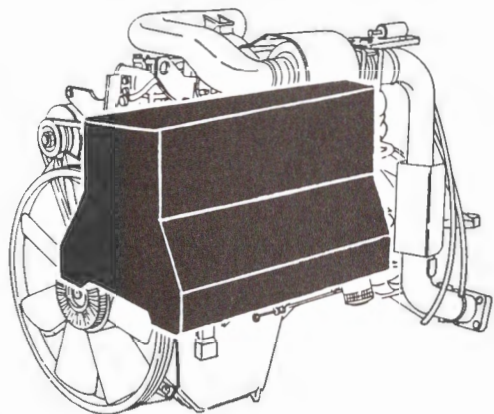

PNOO 2083  
MOS 0103-0001

0102-0001

PN 002083

MOSNR 0102-0001

CILINDERBLOK

DATUM: 890905

BLAD: 1

FIGNR N MC B NSN C FCN REFERENTIENUMMER (= FAN)

ARTIKELOMSCHRIJVING TOELICHTING AANT ECH OPMERKINGEN

5 B 0000-KL-040-9741 2 H0001 0360496

KRAAN, AFTAP-

1 2

KOCHIE.NL

PN 002083

CILINDERBLOK

MOSNR 0102-0001 BLAD: 1

8

-LAATSTE BLAD-

**Y-CHE.ME**

**Y-CHE.ME**

PROJECTNUMMER: 002083

MOSNUMMER : 0102-0004

ZIJDEKSELS

DATUM 871102

BLAD 1 VAN 1 BLADEN

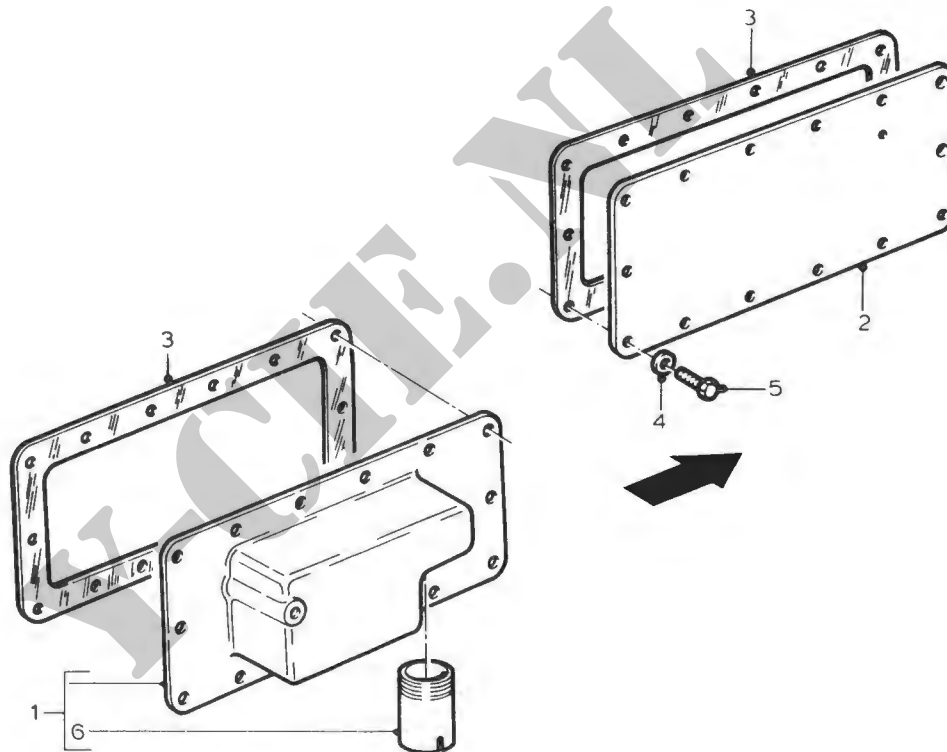
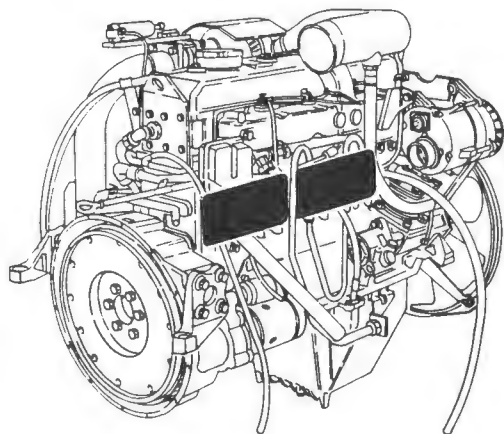

0102-0004

PN 002083

MOSNR 0102-0004

ZIJDEKSELS

DATUM: 890905

BLAD: 1

FIGNR	N	MC	B	NSN	C	FCN	REFERENTIENUMMER (= FAN)	ARTIKELOMSCHRIJVING TOELICHTING	AANT	ECH	OPMERKINGEN
3			B	5330-17-025-1007	3	H0001	0215093	GASKET	2	2	
4			B	5310-12-125-0066	3	H0001	0240528	ONDERLEGRING, VEER-	28	2	
						D8286	DIN137-B8				
5			B	5305-12-156-4863	2	H0001	0251621	SCHROEF, ZESKANTE KO	28	2	
						D8286	DIN933-M8X20-8.8-A2P				

Y-CHE.ML

PN 002083

ZIJDEKSELS

MOSNR 0102-0004 BLAD:

1

**Y-CHE.ME**

**Y-CHE.ME**

PROJECTNUMMER: 002083  
MOSNUMMER : 0106-0001

KLEPPEN,-VEREN,-STOTERS

DATUM 871102  
BLAD 1 VAN 1 BLADEN

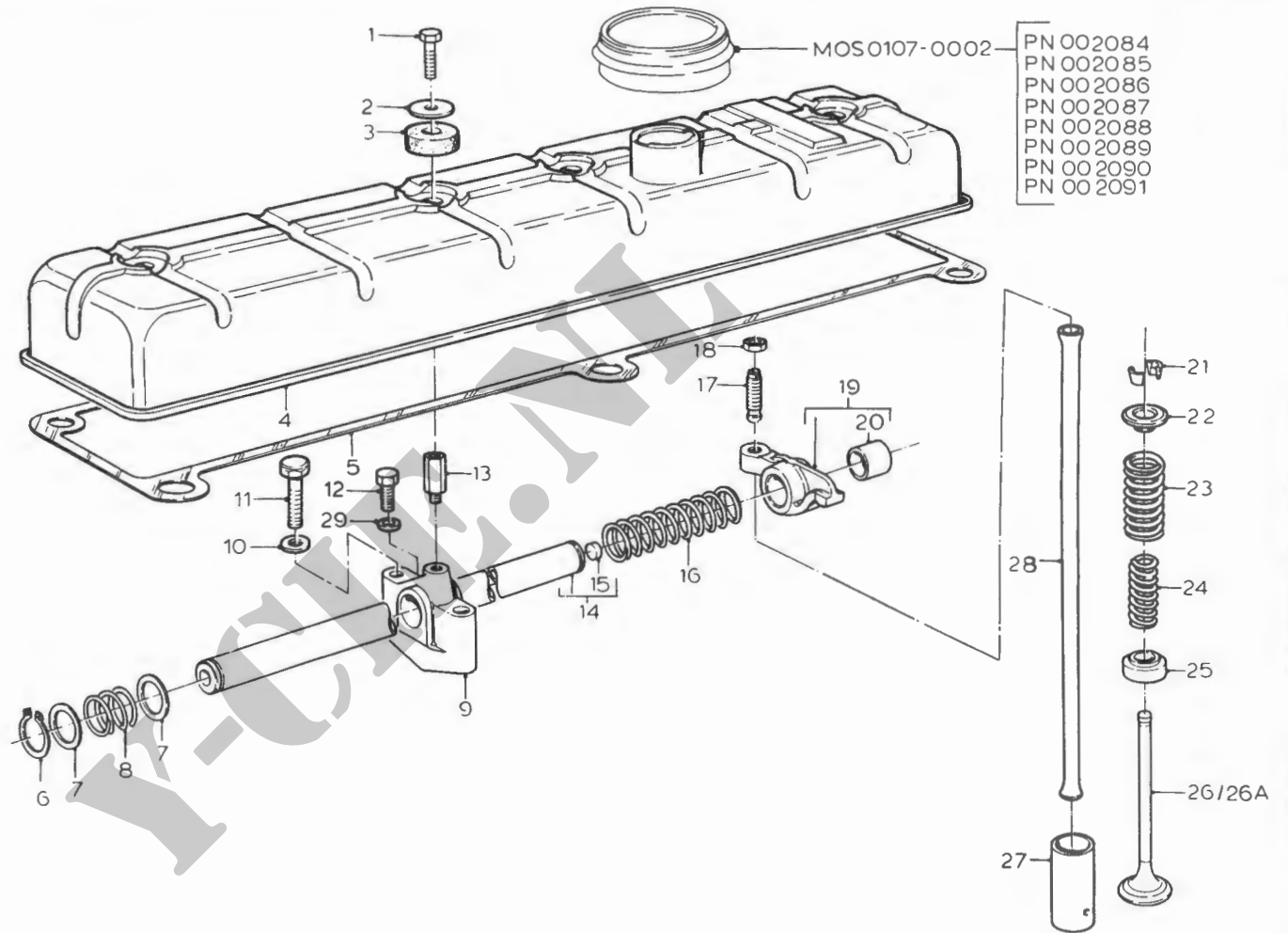
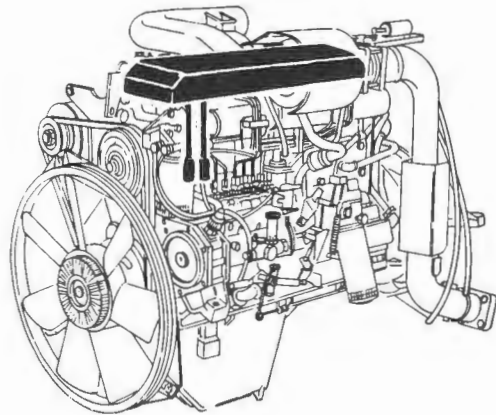

0106-0001

PN 002083

MOSNR 0106-0001

KLEPPEN, -VEREN, -STOTERS

DATUM: 890905

BLAD: 1

FIGNR	N	MC	B	NSN	C	FCN	REFRENTIENUMMER (= FAN)	ARTIKELOMSCHRIJVING	TOELICHTING	AANT	ECH	OPMERKINGEN
1			B	5305-12-167-2507	0	H0001	0126719	SCHROEF, ZESKANTE KO		4	2	
						D8286	DIN933-M8X14-8.8-A2P					
3			B	5310-17-103-4087	4	H0001	0224364	ONDERLEGRING,	SET VAN 4	1	2	
17			B	5306-17-103-5350	2	H0001	0082662	STELSCHROEF		12	2	
18			B	5310-17-034-0840	0	H0001	0240527	MOER, ZESKANT		12	2	

V-CHE.ML

PN 002083

KLEPPEN, -VEREN, -STOTERS

MOSNR 0106-0001 BLAD:

1

10

-LAATSTE BLAD-

**Y-CHE.ME**

**Y-CHE.ME**

PROJECTNUMMER: 002083

MOSNUMMER : 0107-0001

SMEERORGANEN (INW.)

DATUM 871102

BLAD 1 VAN 1 BLADEN

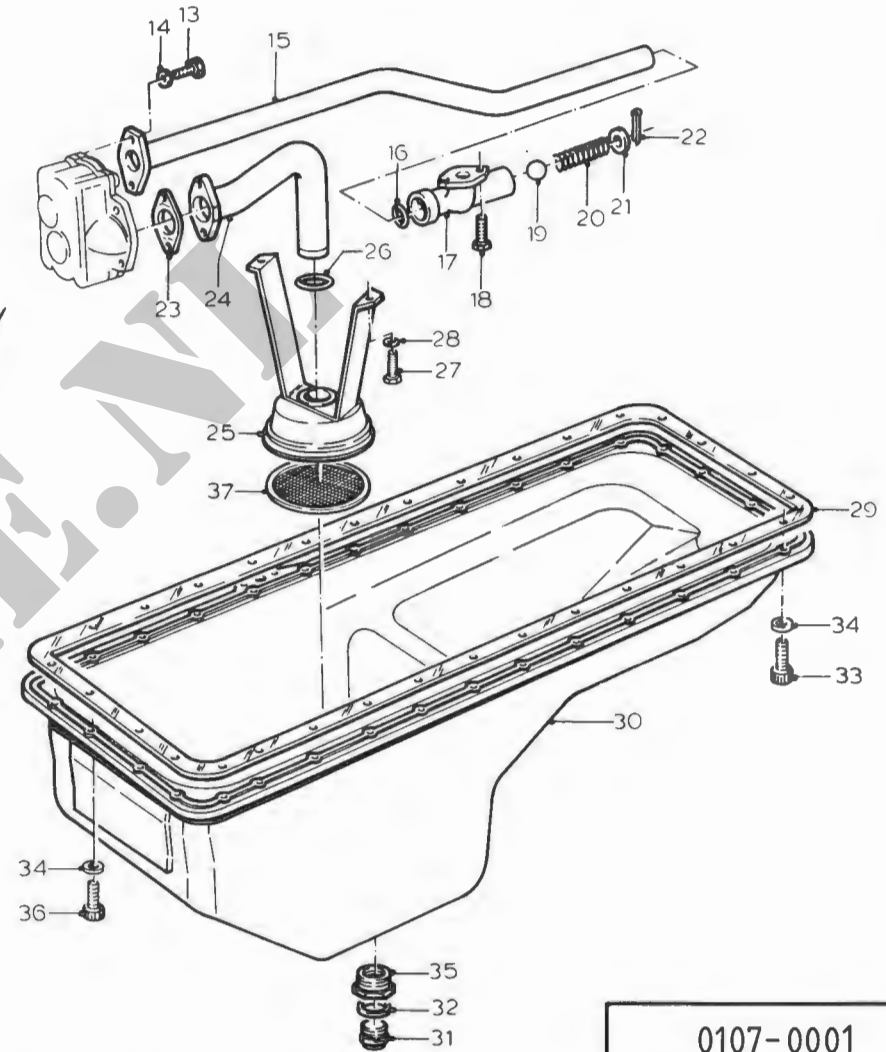
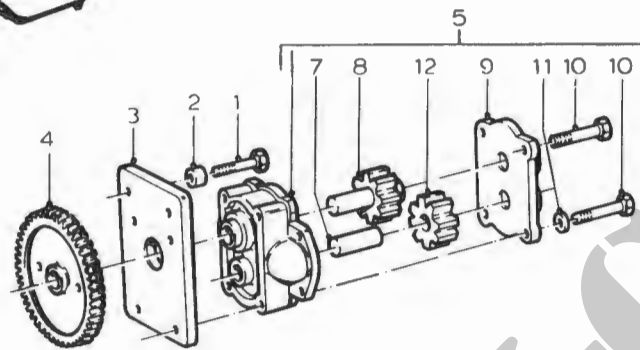
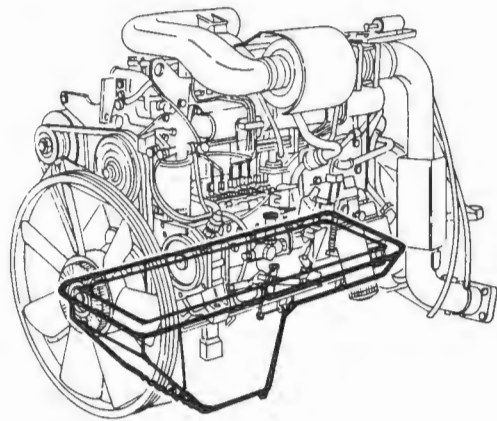

0107-0001

PN 002083

MOSNR 0107-0001

SMEERORGANEN (INW.)

DATUM: 890905 BLAD: 1

FIGNR	N	MC	B	NSN	C	FCN	REFERENTIENUMMER (= FAN)	ARTIKELOMSCHRIJVING TOELICHTING	AANT ECH	OPMERKINGEN
31			B	5365-17-048-5221	5	H0001	0264326	STOP,CILINDRISCHE S	1 2	
				5365-12-151-4279						DIT NSN IS VERVALLEN BIJ BESTELLING
32			B	5330-12-156-4531	0	H0001	0119136	GASKET	1 2	
						D8286	DIN7603-A30X36-CU			
35			B	4730-17-055-3735	0	H0001	0612621	KOPPELSTUK,VERLOOP-	1 2	

KOCHIE.ME

PN 002083

SMEERORGANEN (INW.)

MOSNR 0107-0001 BLAD: 1

**Y-CHE.ME**

**Y-CHE.ME**

PROJECTNUMMER: 002083

MOSNUMMER : 0108-0002

OLIEKOELER

DATUM 871102

BLAD 1 VAN 1 BLADEN

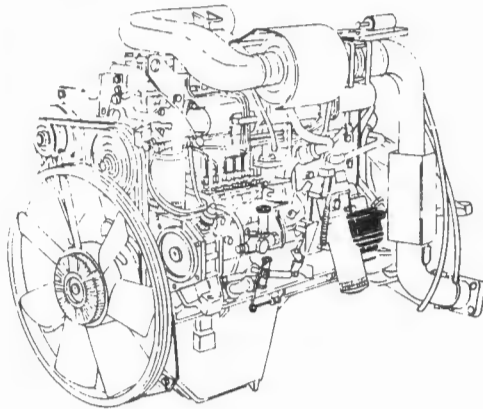

PN  
002084  
002085  
002086  
002087  
002088 MOS 0108-0001  
002089  
002090  
002091

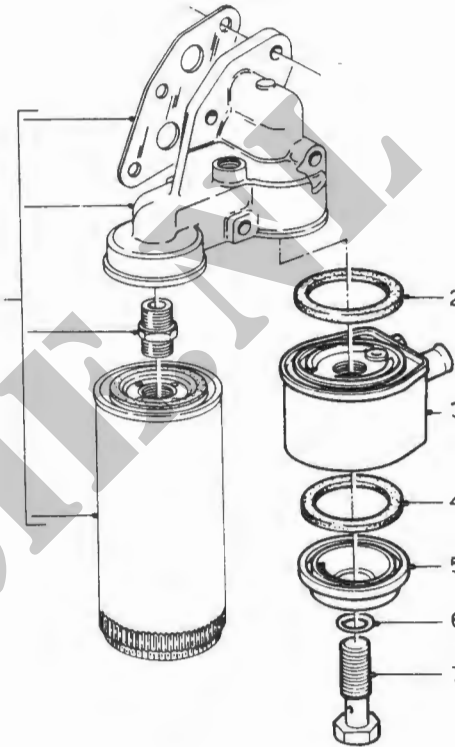

0108-0002

PN 002083

MOSNR 0108-0002

OLIEKOELER

DATUM: 890905

BLAD: 1

FIGNR	N	MC	B	NSN	C	FCN	REFERENTIENUMMER (= FAN)	ARTIKFLOMSCHRIJVING	IOELICHTING	AANT	ECH	OPMERKINGEN
2			B	5330-17-102-9972	3	H0001	0270937	PAKKING, VOORGEVORM		1	2	
3			B	2520-12-318-1204	3	H0001	0270935	KOELER, VLOEISTOF		1	2	
4			B	5330-17-102-9973	4	H0001	0270936	PAKKING, VOORGEVORM		1	2	
6			B	5330-99-717-9054	3	H0001	0649878	RING, SEALING, TOROID		1	2	
						K0640	RM0186-24P5					

Y-CHE.ML

PN 002083

OLIEKOELER

MOSNR 0108-0002

BLAD: 1

**YCHIE.ME**

**Y-CHE.ME**

PROJECTNUMMER: 002083  
MOSNUMMER : 0108-0003

OLIELEID.TURBO COMPRESSOR.

DATUM 871102  
BLAD 1 VAN 1 BLADEN

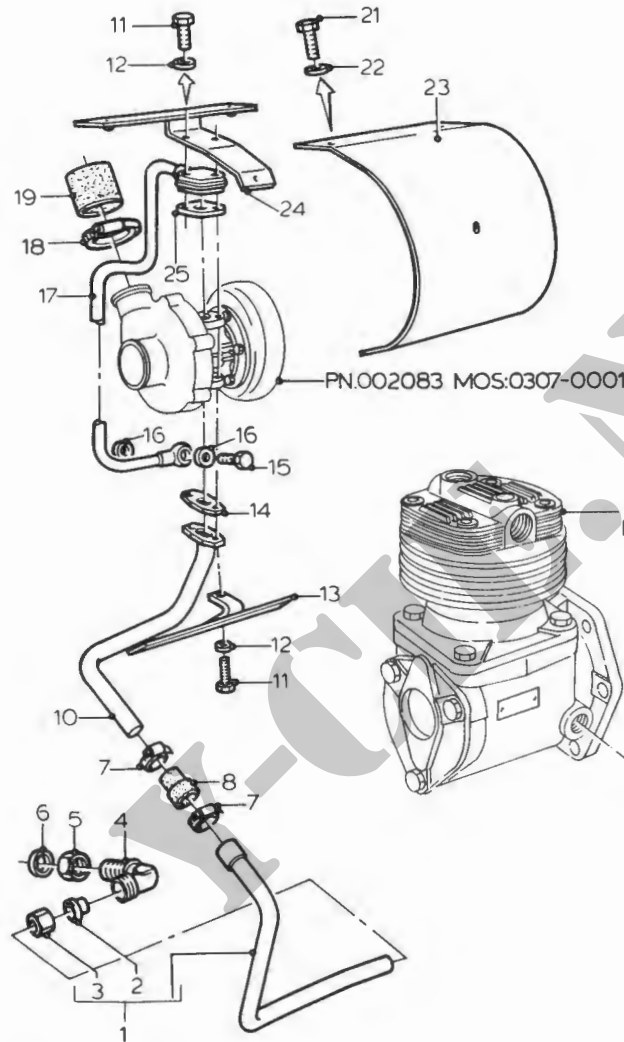
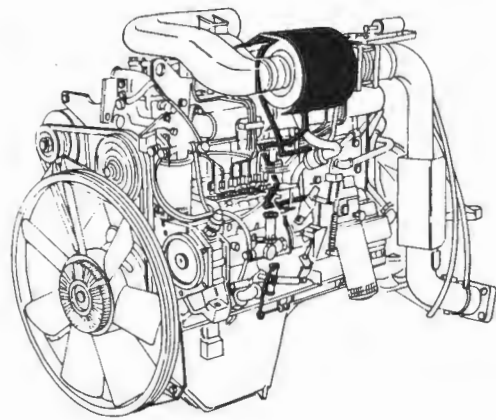

PN.002083  
MOS:0303-0001

PN.002083  
MOS:1203-0001

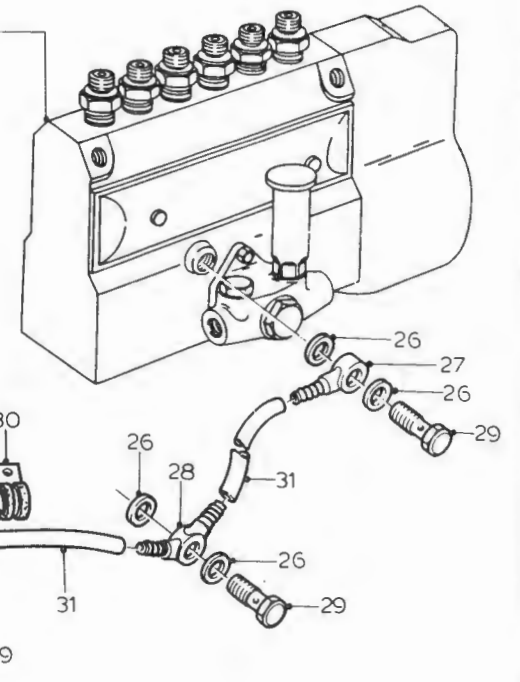

0108-0003

PN 002083

MOSNR 0108-0003

OLIELEID. TURBO-COMPRESSOR

DATUM: 890905

BLAD: 1

FIGNR	N MC	B	NSN	C	FCN	REFERENTIENUMMER (= FAN)	ARTIKELOMSCHRIJVING TOELICHTING	AANT ECH	OPMERKINGEN
1		B	2815-17-103-0386	0	H0001	0893042	LEIDING, OLIE-	1 2	
2		B	4730-12-132-1952	4	D8286	DIN3861-L22-ST-A3P	HULS, INPERS-, PYPFIT	1 2	
3		B	4730-12-132-1911	7	H0001	0211547	MOER, PYPKOPPELING	1 2	0108/0003/00001
					D8286	DIN3870-AL22		1 2	
4		B	4730-17-103-0387	0	H0001	0292557	KNIE, PIJP	1 2	0108/0003/00001
5		B	5310-12-145-2081	3	H0001	0541284	MOER, ZESKANT	2 2	
					D8286	DIN80705-M26X1,5-A2P			
6		B	5310-17-103-3904	8	H0001	0542905	ONDERLEGRING (1), V	1 2	
					H0001	M26X1,5X32X3DAFN.9105			
7		B	4730-12-163-5758	2	H0001	0251973	KLEM, SLANG	2 2	
					D8286	DIN3017-AS25-40C8-W5			
8		B	0000-KL-044-1051	6	H0001	0397242	SLANG, VOORGEVORMD	1 2	
10		B	2815-17-103-0821	5	H0001	0894498	LEIDING, OLIE-	1 2	
11		B	5305-12-142-0511	3	H0001	0251483	SCHROEF, ZESKANTE KO	4 2	
					D8286	DIN931-M8X40-8.8-A2P			
12		B	5310-12-162-2131	4	H0001	0251928	ONDERLEGRING, BORG-	4 2	
					D8286	DIN128-A8			
14		B	5330-17-056-2821	0	H0001	0642979	GASKET	1 2	
15		B	4730-17-103-1066	8	H0001	0635840	BOUT, BANJO-	1 2	
16		B	5330-12-156-4527	7	H0001	0331331	GASKET	2 2	
					D8286	DIN7603-A18X24-CU			
17		B	2815-17-103-0822	6	H0001	0388411	LEIDING, OLIE-	1 2	
18		B	4730-12-163-5756	0	D8286	DIN3017-AS40-60C8-W5	KLEM, SLANG	2 2	
19		B	4720-17-103-0388	1	H0001	0528294	SLANG, LUCHTCIRCULAT	1 2	
21		B	5305-12-146-2633	6	H0001	0126718	SCHROEF, ZESKANTE KO	7 2	
					D8286	DIN933-M6X16-8.8-A2P			
22		B	5310-12-142-0644	4	H0001	0251904	ONDERLEGRING, VLAK	7 2	
					D8286	DIN125-B6,4-ST-A3P			
25		B	5330-17-102-7210	2	H0001	0642980	GASKET	1 2	
26		B	5330-12-156-4518	9	H0001	0331327	GASKET	6 2	
					D8286	DIN7603-A10X14-CU			
27		B	4730-12-179-1616	1	H0001	0263256	AANSLUITSTUK, MEERVO	2 2	
					D9596	023522			
28		B	5340-17-909-8307	3	H0001	0671137	BANJOHUIS	1 2	
					C1618	261004040090GR			
29		B	4730-12-158-8862	0	H0001	0232055	BOUT, BANJO	3 2	
					D8286	DIN7643-6			
30		B	5340-12-166-0529	1	H0001	0252391	KLEM, LUS	1 2	
					D8286	DIN3016-D1-6X20-W1-2			

PN 002083

OLIELEID. TURBO-COMPRESSOR

MOSNR 0108-0003 BLAD:

1

PN 002083

MOSNR 0108-0003

OLIELEID. TURBO-COMPRESSOR

DATUM: 890905 BLAD: 2

FIGNR N MC B

NSN

C

FCN

REFERENTIENUMMER (= FAN)

ARTIKELOMSCHRIJVING TOELICHTING

AANT ECH

OPMERKINGEN

31

B 4720-12-173-8647 8

H0001 0799007

D8286 DIN73378-PA11WSWLT-6X1

PYP, NIET METAAL

NB 2

MR

Y-CHE.ML

PN 002083

OLIELEID. TURBO-COMPRESSOR

MOSNR 0108-0003 BLAD: 2

14

-LAATSTE BLAD-

**Y-CHE.ME**

PROJECTNUMMER: 002083  
MOSNUMMER : 0110-0001

# MOTORREM MET BEDIENING

DATUM 871102  
BLAD 1 VAN 1 BLADEN

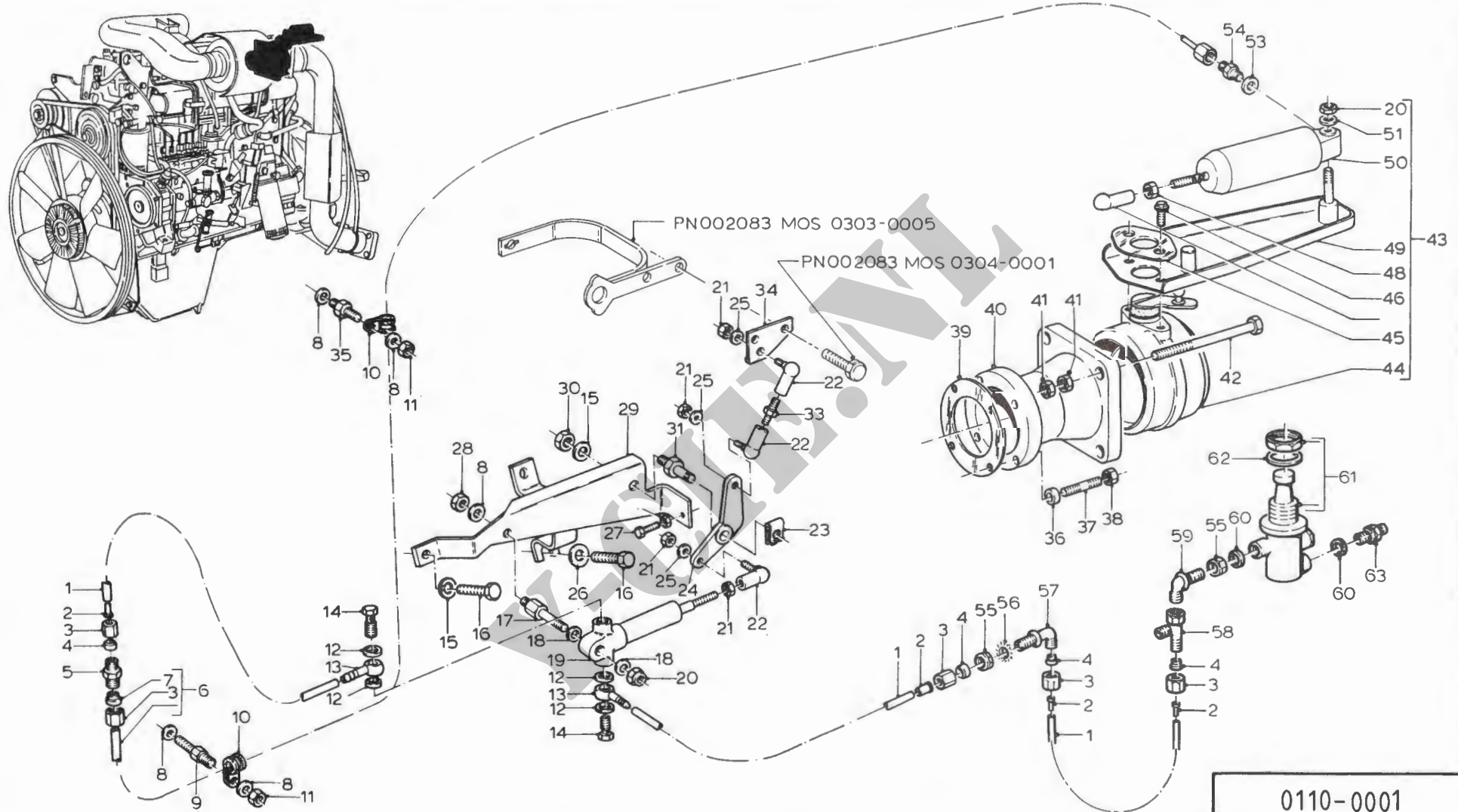

PN 002083

MOSNR 0110-0001

MOTORREM MET BEDIENING

DATUM: 890905

BLAD: 1

FIGNR	N MC	B	NSN	C	FCN	REFERENTIENUMMER (= FAN)	ARTIKELOMSCHRIJVING TOELICHTING	AANT ECH	OPMERKINGEN
1		B	4720-12-173-8647	8	H0001	0799007	PYP, NIET METAAL	1 2	MR
					D8286	DIN73378-PA11WSWLT-6X1			
2		B	4730-12-174-0669	6	H0001	0624109	HULS, TROMPETVORMIG,	1 2	
					D8096	8930402104			
3		B	4730-12-132-5661	6	H0001	0226483	MOER, PYPKOPPELING	3 2	
					D8286	DIN3870-AL6			
4		B	4730-12-132-5660	5	H0001	0624112	HULS, INPERS-, PYPFIT	1 2	
					D8286	DIN3861-L6-ST-A3P			
5		B	4730-12-151-9993	1	H0001	0226566	KOPPELSTUK	1 2	
					D8286	DIN3902-L6-ST			
6		B	2815-17-103-0820	4	H0001	0393246	LEIDING STAAL	1 2	
7		B	4730-12-132-5660	5	H0001	0226480	HULS, INPERS-, PYPFIT	2 2	
					D8286	DIN3861-L6-ST-A3P			
8		B	5310-12-162-2131	4	H0001	0251928	ONDERLEGRING, BORG-	7 2	
					D8286	DIN128-A8			
9		B	5307-17-052-7092	0	H0001	0167845	TAPEIND, BORST	1 2	
10		B	5340-12-166-0529	1	H0001	0252391	KLEM, LUS	3 2	
					D8286	DIN3016-D1-6X20-W1-2			
11		B	5310-12-144-6120	4	H0001	0251283	MOER, ZESKANT	3 2	
					D8286	DIN439-BM8-05-A2P			
12		B	5330-12-156-4805	0	H0001	0331328	GASKET	4 2	
					D8286	DIN7603-A12X17-CU			
13		B	4730-12-175-6826	4	H0001	0263257	AANSLUITSTUK, MEERVO	2 2	
					D9596	023682			
14		B	4730-12-124-1298	2	H0001	0243734	BOUT, BANJO	2 2	
					D8286	DIN7623-A6-6.8			
15		B	5310-12-162-2130	3	H0001	0251929	ONDERLEGRING, BORG-	3 2	
					D8286	DIN128-A10			
16		B	5305-12-158-0033	3	H0001	0126721	SCHROEF, ZESKANTE KO	3 2	
					D8286	DIN933-M10X16-8.8-A3P			
17		B	5315-17-103-0406	8	H0001	0364113	PEN, LAGER-	1 2	
18		B	5310-12-149-4353	2	H0001	0325421	ONDERLEGRING, VLAK	2 2	
					D8286	DIN125-A8, 4-ST-A3P			
19		B	2910-12-305-2772	7	H0001	0276480	CILINDERSAMENSTEL, B	1 2	
					C1208	516-3.2077			
20		B	5310-12-167-1881	1	D8286	DIN982-M8-8-A2P	MOER, ZELFBORGEND, ZE	2 2	
21		B	5310-12-156-4991	9	H0001	0251274	MOER, ZESKANT	5 2	
					D8286	DIN934-M6-8-A2P			
22		B	3040-12-124-4566	3	H0001	0572638	KOGELGEWRIJCHT, ENKEL	3 2	
					D8286	DIN71802-ASX10M6XM6			
23		B	5340-12-159-3495	1	H0001	0591546	KLEM, VEER-	1 2	
					D9414	10SXN08			

PN 002083

MOTORREM MET BEDIENING

MOSNR 0110-0001

BLAD: 1

PN 002083

MOSNR 0110-0001

MOTORREM MET BEDIENING

DATUM: 890905

BLAD: 2

FIGNR	N MC	B	NSN	C	FCN	REFERENTIENUMMER (= FAN)	ARTIKELOMSCHRIJVING TOELICHTING	AANT ECH	OPMERKINGEN
24		B	2530-17-103-4188	6	H0001	0890110	TUIMELHEFBOOM	1 2	
25		B	5310-12-162-2129	2	H0001	0251927	ONDERLEGRING, BORG-	3 2	
					D8286	DIN128-A6-FST			
26		B	5310-12-142-0481	6	H0001	0202817	ONDERLEGRING, VLAK	1 2	
					D8286	DIN125-B10, 5-ST-A3P			
27		B	5305-12-141-9849	1	H0001	0251616	SCHROEF, ZESKANTE KO	1 2	
					D8286	DIN933-M6X35-8.8-A2P			
28		B	5310-12-144-6214	0	H0001	0251275	MOER, ZESKANT	1 2	
					D8286	DIN934-M8-8-A2P			
30		B	5310-12-156-4996	3	H0001	0251276	MOER, ZESKANT	1 2	
					D8286	DIN934-M10-8-A2P			
31		B	3040-17-103-0825	9	H0001	0364953	AS, HEFBOOM	1 2	
33		B	5307-17-103-1528	8	H0001	0364115	TAPE IND, BORST-	1 2	
34		B	2815-17-103-1529	9	H0001	0364114	PLAAT, BEVESTIGINGS-	1 2	
35		B	5307-17-103-1530	0	H0001	0288468	TAPE IND, BORST-	1 2	
36		B	5365-17-103-1531	0	H0001	0363572	AFSTANFSTUK, BUS	4 2	
37		B	5307-17-049-6684	6	H0001	0613580	TAPE IND, CILINDRISCH	4 2	
38		B	5310-17-049-6577	9	H0001	0166201	MOER, ZESKANT	4 2	
39		B	5330-17-103-1532	1	H0001	0558727	GASKET	1 2	
41		B	5310-17-049-4972	0	H0001	0588866	MOER, ZESKANT	8 2	
42		B	5306-17-056-1849	7	H0001	0534953	BOUT, MACHINE	4 2	
43		B	2990-12-316-6643	6	D1818	KS5307-12	MOTORREM	1 2	R
45		B	2990-17-910-7155	7			AFSTANDSTUK, PLAAT	1 2	
									DIT NSN IS VERVALLEN
									0110/0001/00043
									BIJ BESTELLING
46		B	5306-12-317-5568	0	H0001	0268977	BOUT, MACHINE	2 2	
					D8286	DIN6921-M8X20-8.8-A2P			
48		B	5310-12-144-6214	0	H0001	0251275	MOER, ZESKANT	1 2	
					D8286	DIN934-M8-8-A2P			
49		B	2990-17-910-7156	8			STEUN	1 2	
									DIT NSN IS VERVALLEN
									0110/0001/00043
									BIJ BESTELLING
50		B	2530-12-186-1145	0	H0001	0513932	CILINDER, BEDIENINGS	1 2	
					D1818	KS3013			
51		B	5310-12-145-5250	4	H0001	0251913	ONDERLEGRING, VLAK	1 2	
					D8286	DIN433-8,4-ST-A3P			
53		B	5330-12-156-4518	9	H0001	0331327	GASKET	1 2	
					D8286	DIN7603-A10X14-CU			

PN 002083

MOTORREM MET BEDIENING

MOSNR 0110-0001 BLAD:

2

PN 002083

MOSNR 0110-0001

MOTORREM MET BEDIENING

DATUM: 890905

BLAD: 3

FIGNR	N	MC	B	NSN	C	FCN	REFERENTIENUMMER (= FAN)	ARTIKELOMSCHRIJVING TOELICHTING	AANT	ECH	OPMERKINGEN
54			B	4720-17-049-7303	9	H0001	0507207	KOPPELSTUK, VERLOOP-	1	2	
55			B	5310-12-144-2186	8	H0001	0226490	MOER, ZESKANT	2	2	
						D8286	DIN80705-M12X1,5-A2P				
56			B	5310-12-124-0894	5	D8286	DIN6798-A12,5	ONDERLEGRING, BORG-	1	2	
						D8286	DIN6798-A12,5				
57			B	4730-17-103-1554	1	H0001	0368988	KNIE, PIJP	1	2	
58			B	4730-17-103-1544	2	H0001	0369001	T-STUK, PIJP	1	2	
59			B	4730-17-103-1543	1	H0001	0285447	KNIE, PIJP	1	2	
60			B	5330-17-049-8488	6	H0001	0206786	PAKKINGRING MET HOU	2	2	
						H0001	M12X1,5X16X2,5 DAFNORM.9105				
61			B	2530-12-314-3920	9	H0001	0629958	VALVE, MOTORBRAKE	1	2	
62			B	5310-17-049-7046	5	H0001	0249406	ONDERLEGRING, VLAKE	1	2	
63			B	4730-17-103-1545	3	H0001	0285442	NIPPEL, PIJP	1	2	

PN 002083

MOTORREM MET BEDIENING

MOSNR 0110-0001 BLAD:

3

17

-LAATSTE BLAD-

**Y-CHE.ME**

**Y-CHE.ME**

PROJECTNUMMER: 002083

MOSNUMMER : 0111-0001

VENTILATOR

DATUM 871102

BLAD 1 VAN 1 BLADEN

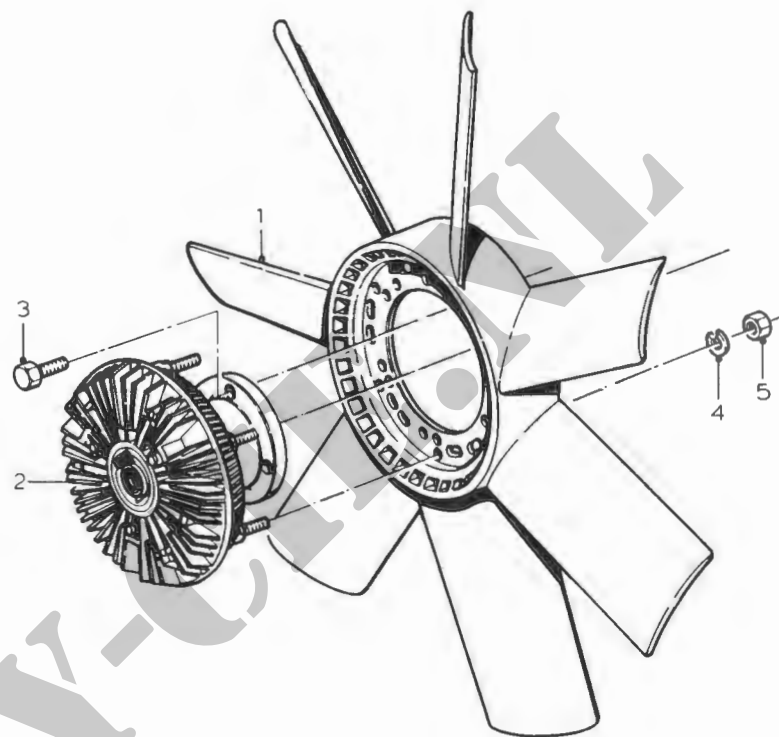
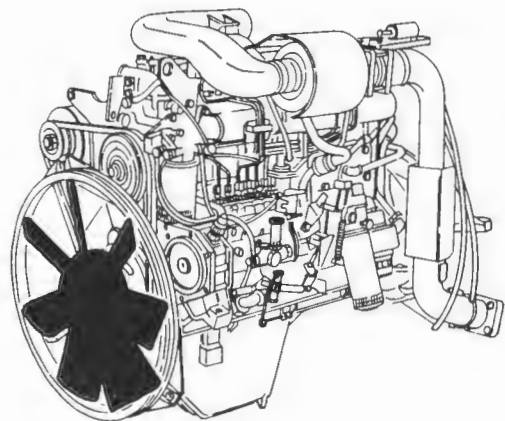

0111-0001

PN 002083

MOSNR 0111-0001

VENTILATOR

DATUM: 890905

BLAD: 1

FIGNR	N	MC	B	NSN	C	FCN	REFERENTIENUMMER (= FAN)	ARTIKELOMSCHRIJVING TOELICHTING	AANT ECH	OPMERKINGEN
1			B	2815-17-103-1533	2	H0001	0281378	WAAIER, VENTILATOR	1 2	
2			B	0000-KL-040-9924	9	H0001	0222355	KOPPELING VENTILATO	1 2	
3			B	5305-12-156-4858	8	H0001	0251635	SCHROEF, ZESKANTE KO	4 2	
4			B	5310-12-162-2131	4	H0001	0251928	ONDERLEGRING, BORG-	6 2	
5			B	5310-12-144-6214	0	H0001	0251275	MOER, ZESKANT	6 2	
						D8286	DIN933-M10X35-8.8-A3P			
						D8286	DIN128-A8			
						D8286	DIN934-M8-8-A2P			

Y-CHE.ME

PN 002083

VENTILATOR

MOSNR 0111-0001

BLAD: 1

**KCH.ME**

**Y-CHE.ME**

PROJECTNUMMER: 002083

MOSNUMMER : 0111-0002

SNAARSCHIJVEN EN RIEMEN

DATUM 871102

BLAD 1 VAN 1 BLADEN

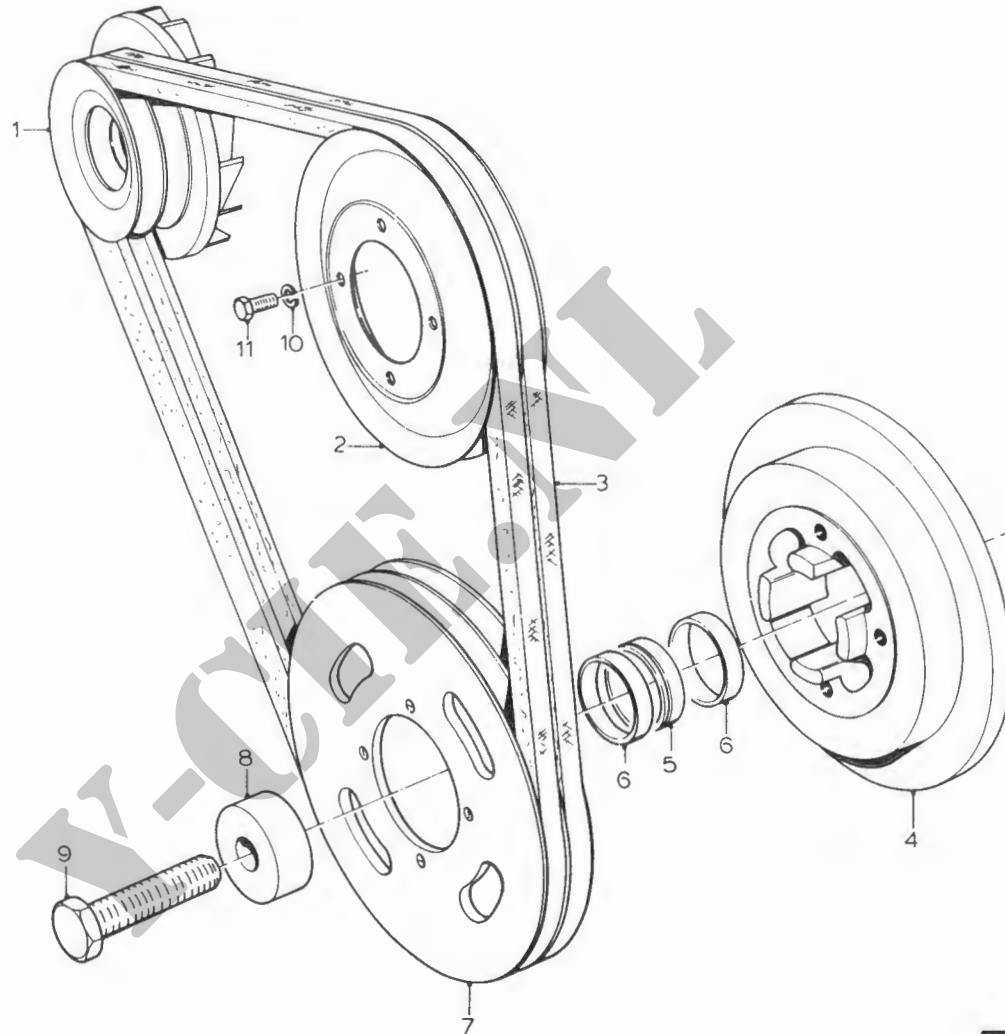
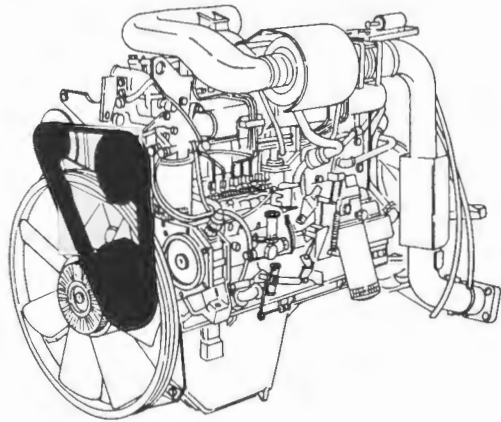

0111-0002

PN 002083

MOSNR 0111-0002

SNAARSCHIJVEN EN RIEMEN

DATUM: 890905

BLAD: 1

FIGNR	N	MC	B	NSN	C	FCN	REFERENTIENUMMER (= FAN)	ARTIKELOMSCHRIJVING TOELICHTING	AANT	ECH	OPMERKINGEN
2			B	2815-17-103-3906	0	H0001	0276129	SCHYF, SNAAR	1	2	
3			B	3030-17-034-0955	4	H0001	0243941	RIEM, V	2	2	
7			B	2815-17-103-1535	4	H0001	0277046	SCHYF, SNAAR-	1	2	
9			B	5305-12-144-5237	1	H0001	0371716	SCHROEF, ZESKANTE KO	1	2	
						D8286	DIN931-M20X80-10.9-A3P				
10			B	5310-12-162-2131	4	H0001	0251928	ONDERLEGRING, BORG-	4	2	
						D8286	DIN128-A8				
11			B	5305-12-155-6878	3	H0001	0126720	SCHROEF, ZESKANTE KO	4	2	
						D8286	DIN933-M8X16-8.8-A2P				

PN 002083

SNAARSCHIJVEN EN RIEMEN

MOSNR 0111-0002 BLAD: 1

19

-LAATSTE BLAD-

Y-CHE.ME

**YCHIE.ME**

PROJECTNUMMER: 002083  
MOSNUMMER : 0301-0001

BRANDSTOFTANK

DATUM 871102  
BLAD 1 VAN 1 BLADEN

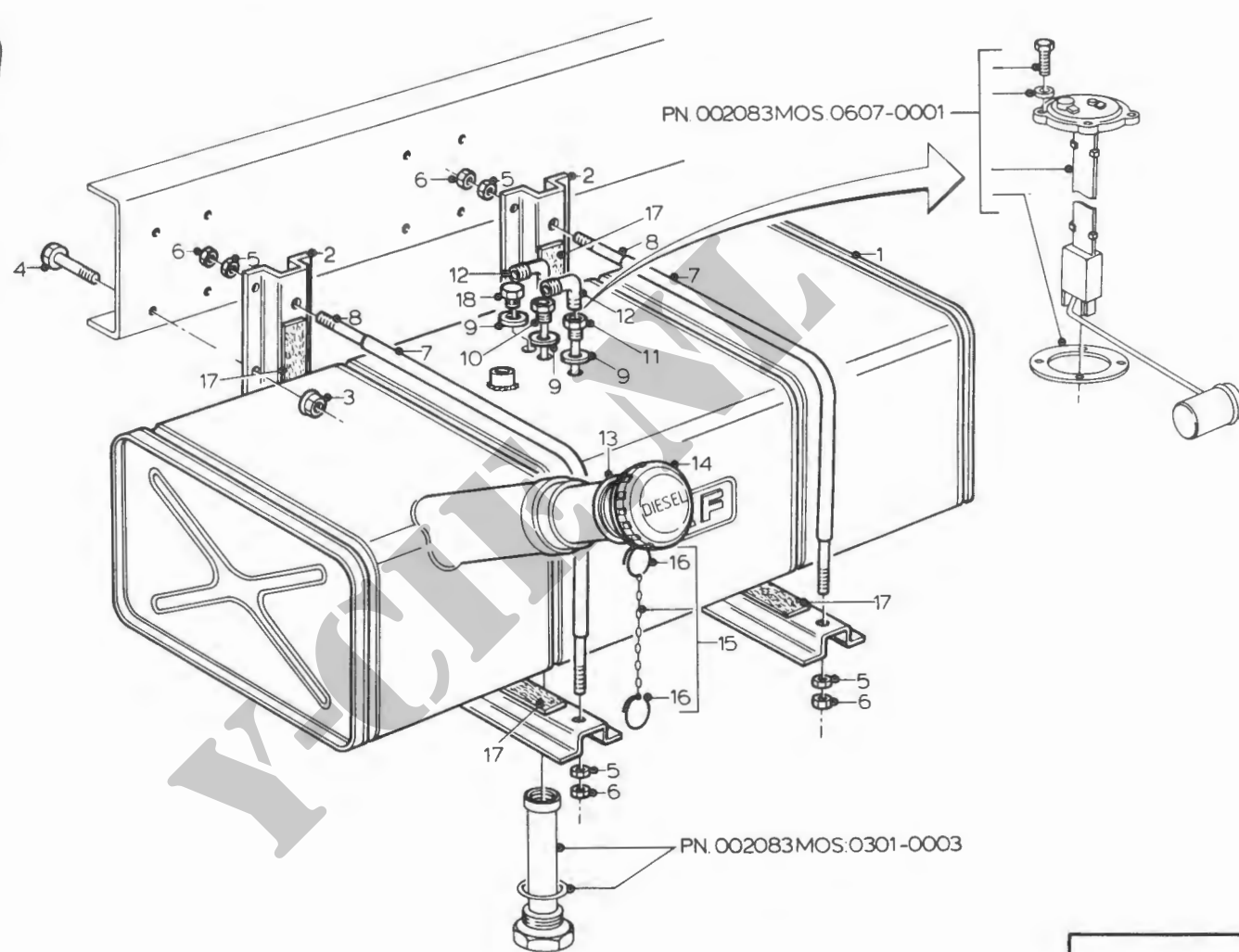
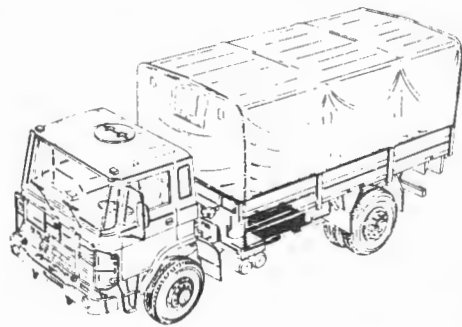

0301-0001

PN 002083

MOSNR 0301-0001

BRANDSTOFTANK

DATUM: 890905

BLAD: 1

FIGNR	N	MC	B	NSN	C	FCN	REFERENTIENUMMER (= FAN)	ARTIKELOMSCHRIJVING TOELICHTING	AANT ECH	OPMERKINGEN
1			B	2910-17-049-6701	1	H0001	0611995	TANK, BRANDSTOF, MOTO	1	2
2			B	2910-17-049-7312	7	H0001	0611272	DRAGER, BRANSTOFTANK	2	2
3			B	5310-17-050-9991	3	H0001	0638049	MOER, KRAAG, ZESKANT	6	2
4			B	5306-17-050-7994	8	H0001	0638042	BOUT, BORST	6	2
5			B	5310-12-128-6339	9	H0001	0523875	MOER, ZESKANT	4	2
						D8286	DIN936-M10X1,25-05-ZNPHRF			
6			B	5310-12-191-9305	2	H0001	0523871	MOER, ZESKANT	4	2
						D8286	DIN934-M10X1,25-8-A2P			
7			B	4720-12-317-5828	6	H0001	0799005	SLANG, NIET-METAAL	NB	2 MR
						D8286	DIN74324-10X1,25			
8			B	5306-17-049-6947	5	H0001	0611338	STANG, NIET DOORLOPE	2	2
9			B	5330-12-156-4525	5	H0001	0322364	GASKET	3	2
						D8286	DIN7603-A16X22-CU			
10			B	4710-17-049-8353	3	H0001	0611270	PYPSAMENSTEL, METAAL	1	2
11			B	4710-17-049-8352	2	H0001	0611269	PYPSAMENSTEL, METAAL	1	2
12			B	4730-17-049-6835	3	H0001	0502791	KNIE, PYP	2	2
13			B	2910-17-049-7075	1	H0001	0611671	ZEEFELEMENT, BEZINKS	1	2
14			B	2815-17-102-9976	7	H0001	0557836	DOP VULOPENING	1	2
15			B	4010-17-017-6974	0			KETTINGSAMENSTEL, EN	1	2
16			B	5365-17-022-4723	9	H0001	0132910	RING, VERBINDING, RON	2	2
										0301/0001/00015
17			B	2815-17-103-2044	7	H0001	0297644	PROFIEL, AFWERK-	NB	2
18			B	5365-12-134-6167	8	H0001	0547744	STOP, CILINDRISCHE S	1	2
						D8286	DIN910-M16X1,5-ST			

PN 002083

BRANDSTOFTANK

MOSNR 0301-0001 BLAD: 1

20

-LAATSTE BLAD-

**YCHIE.ME**

**YCHIE.ME**

PROJECTNUMMER: 002083  
MOSNUMMER : 0301-0002

BRANDSTOFLEIDINGEN

DATUM 871102  
BLAD 1 VAN 1 BLADEN

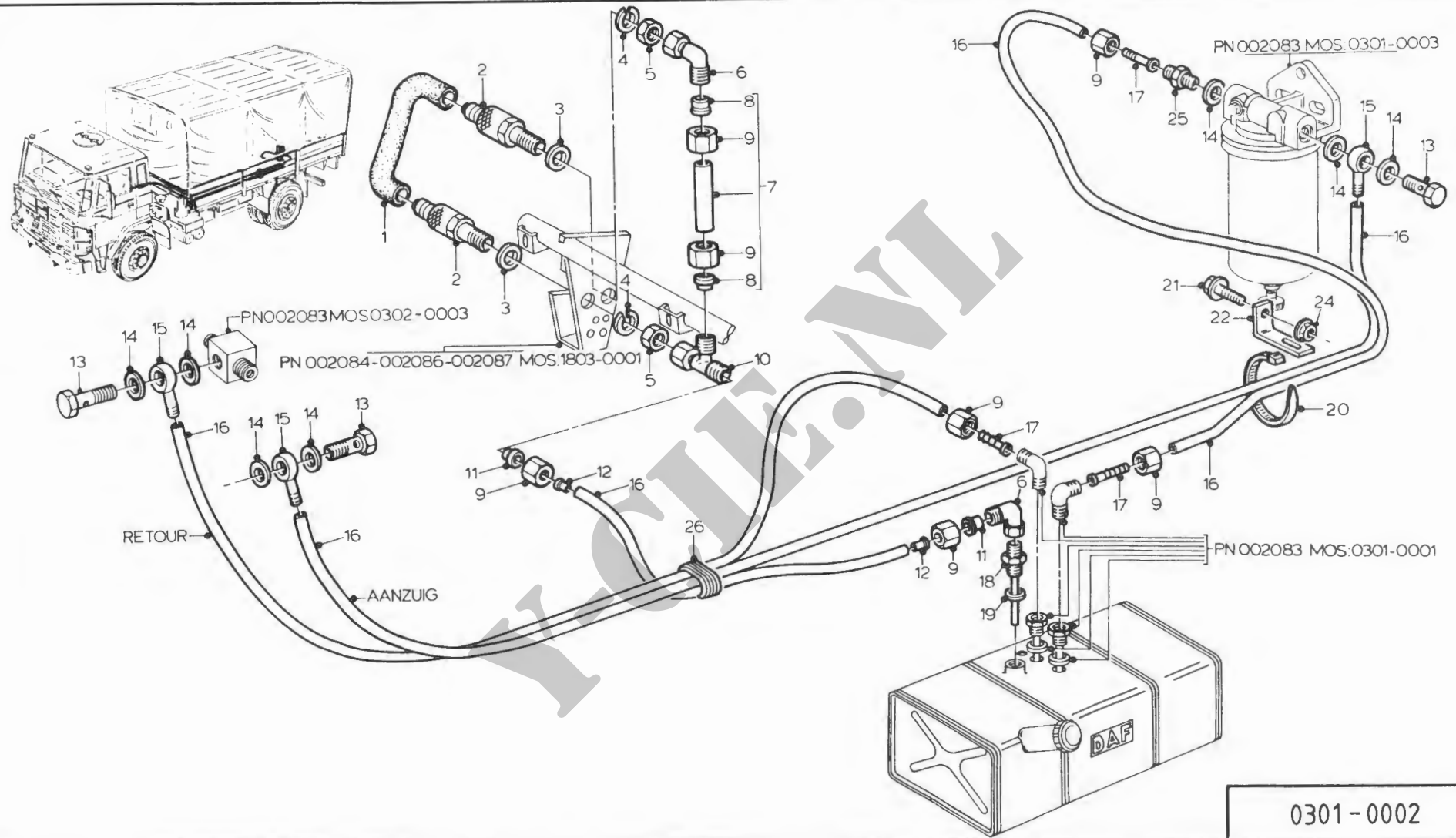

0301-0002

PN 002083

MOSNR 0301-0002

BRANDSTOFLEIDINGEN

DATUM: 890905

BLAD: 1

FIGNR	N MC	B	NSN	C	FCN	REFERENTIENUMMER (= FAN)	ARTIKELOMSCHRIJVING TOELICHTING	AANT ECH	OPMERKINGEN
2		B	4730-12-175-6831	9	H0001	0622336	KOPPELINGHELFT, SNEL	2 2	
					D2288	SP006-2XX211-11-2			
3		B	5310-12-142-0640	0	H0001	0251917	ONDERLEGRING, VLAK	2 2	
					D8286	DIN125-B17-ST-A3P			
4		B	5310-12-162-2133	6	H0001	0251932	ONDERLEGRING, BORG-	2 2	
					D8286	DIN128-A16			
5		B	5310-12-145-2077	0	H0001	0107233	MOER, ZESKANT	2 2	
					D8286	DIN80705-M16X1,5-A2P			
6		B	4730-12-128-4442	4	H0001	0261009	KNIE, PYP	2 2	
					D8286	DIN2353-KL10-ST			
8		B	4730-12-137-6457	4	H0001	0146141	HULS, INPERS-, PYPFIT	2 2	
					D8286	DIN3861-L10-ST-A3P			
9		B	4730-12-123-4179	0	H0001	0146142	MOER, PYPKOPPELING	4 2	
					D8286	DIN3870-AL10			
10		B	4730-12-174-0674	0	D9596	162121	T-STUK, PYP	1 2	
11		B	4730-12-172-1015	9	H0001	0624113	HULS, COMPRESSIE, PYP	2 2	
13		B	4730-12-124-1299	3	H0001	0240559	BOUT, BANJO	3 2	
					D8286	DIN7623-A8-6.8			
14		B	5330-12-156-4523	3	D8286	DIN7603-A14X20-CU	GASKET	7 2	
15		B	4730-12-173-7541	2	H0001	0116631	AANSLUITSTUK, MEERVO	3 2	
					D9596	023572			
16		B	4720-12-317-5828	6	H0001	0799005	SLANG, NIET-METAAL	NB 2	MR
					D8286	DIN74324-10X1,25			
17		B	4730-12-173-7088	0	H0001	0118163	AANPASSTUK, RECHT, PY	3 2	
					D9596	023972			
18		B	4710-17-050-4279	0	H0001	0622300	PYPSAMENSTEL, METAAL	1 2	
19		B	5330-12-156-4805	0	H0001	0331328	GASKET	1 2	
					D8286	DIN7603-A12X17-CU			
20		B	5975-00-451-5001	7	H0001	0657954	RIEM, BIND-, ELEKTRIS	NB 2	
					96906	MS3367-3-9			
21		B	5305-17-103-0050	4	H0001	0362030	SCHROEF, ZESKANT KOP	2 2	
					D8286	M8X25X21X18,0X13X8.8			
22		B	5340-17-054-9431	8	H0001	0661200	STEUN	2 2	
24		B	5310-17-915-1028	1	H0001	0268985	MOER, FLENS-	2 2	
25		B	0000-KL-040-9937	0	H0001	0260889	NIPPEL, VERLOOP-	1 2	
					D2456	A0472			

PN 002083

BRANDSTOFLEIDINGEN

MOSNR 0301-0002 BLAD: 1

21

-LAATSTE BLAD-

**YCHIE.ME**

**YCHIE.ME**

PROJECTNUMMER: 002083

MOSNUMMER : 0301-0003

BRANDSTOFFFILTERS

DATUM 871102

BLAD 1 VAN 1 BLADEN

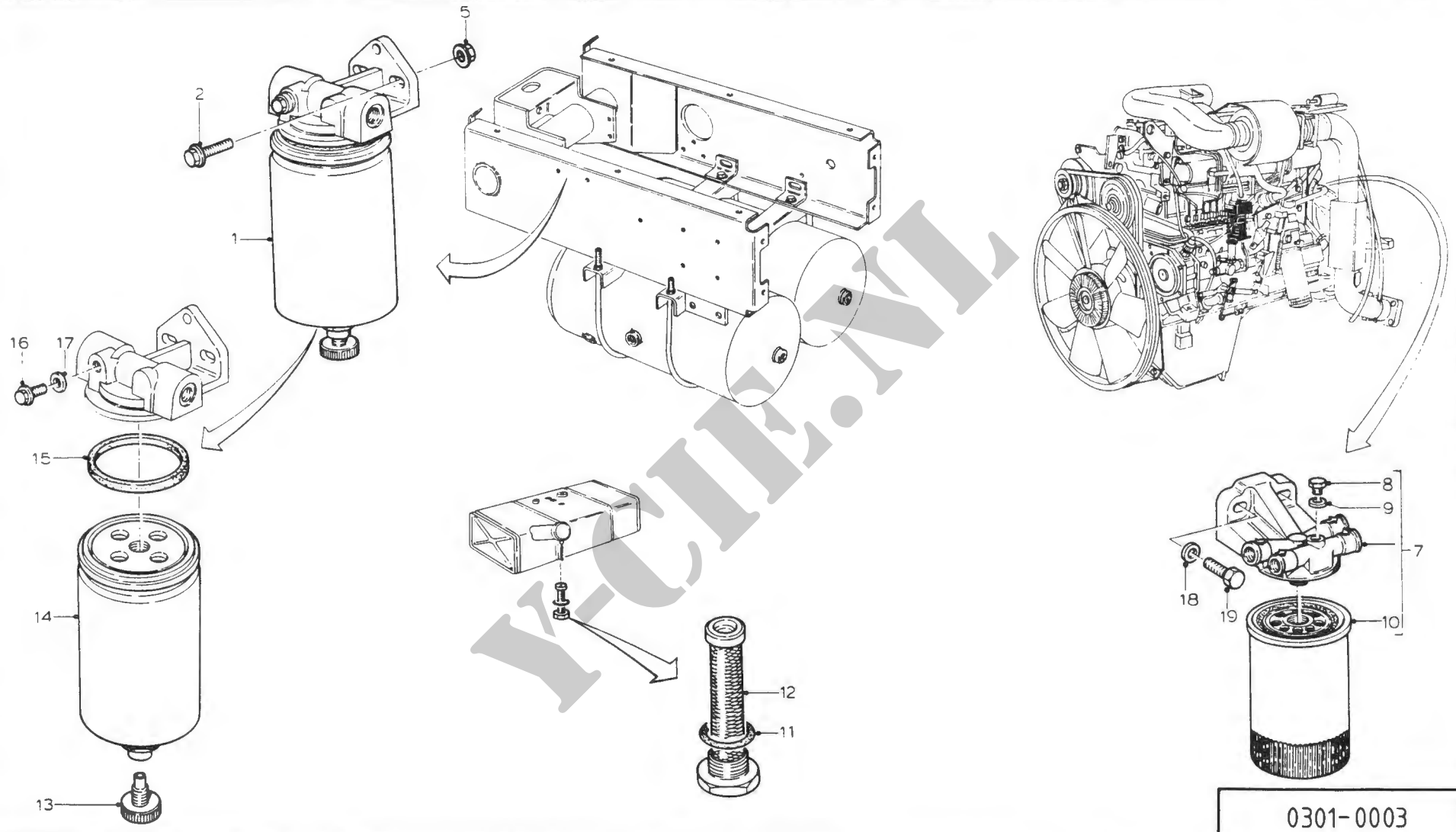

PN 002083

MOSNR 0301-0003

BRANDSTOFFILTERS

DATUM: 890905

BLAD: 1

FIGNR	N	MC	B	NSN	C	FCN	REFERENTIENUMMER (= FAN)	ARTIKELOMSCHRIJVING TOELICHTING	AANT ECH	OPMERKINGEN
1			B	2940-12-301-8746	4	H0001	0633101	FILTER, FLUID	1 2	
						D1560	11239			
2			B	5305-17-103-0050	4	H0001	0362030	SCHROEF, ZESKANT KOP	3 2	
						D8286	DIN6921-M8X25-8.8			
5			B	5310-17-915-1028	1	H0001	0268985	MOER, FLENS-	3 2	
						D8286	DIN6923-M8X17, 9X8X13X8			
7			B	2910-12-316-9240	7	D8086	6650562102	FILTER, FLUIDMNI	1 2	R
8			B	5365-12-315-9253	8	H0001	0247310	ONTLUCHTINGSSCHROEF	1 2	
						D8086	2100805121			
9			B	5330-12-150-9938	0	H0001	0242097	GASKET	0301/0003/00007	
						D8286	DIN7603-A8X12-CU		1 2	
10			B	2910-17-045-6667	7	H0001	0247139	FILTERELEMENTSAMENS	0301/0003/00007	
									1 2	
11			B	5330-17-102-9983	3	H0001	0891215	PAKKING, VOORGEVORM	0301/0003/00007	
13			B	5365-12-313-9481	3	H0001	0695833	STOP, CILINDRISCHE S	1 2	HB
						D8081	1440640060		1 2	
14			B	2940-12-309-0569	8	H0001	0695832	FILTER (1), FLUIDUM	1 2	
						D1560	511.2409.000			
15			B	5330-12-302-9145	8	H0001	0695834	GASKET	1 2	
						D1560	1453800020			
16			B	5306-17-907-1727	0	H0001	0695831	BOUT, BORST	1 2	
						D1560	1440650000			
17			B	5330-12-132-7079	5	D8286	DIN7603-A8X13-CU	GASKET	1 2	
18			B	5310-12-145-2243	0	H0001	0709155	ONDERLEGRING, VLAK	2 2	
						D8286	DIN7349-10,5-ST-A3P			
19			B	5305-12-156-4858	8	H0001	0251635	SCHROEF, ZESKANTE KO	2 2	
						D8286	DIN933-M10X35-8.8-A3P			

PN 002083

BRANDSTOFFILTERS

MOSNR 0301-0003 BLAD: 1

**Y-CHE.ME**

**Y-CHE.ME**

PROJECTNUMMER: 002083  
MOSNUMMER : 0302-0002

# INSPUITLEIDINGEN

DATUM 871102  
BLAD 1 VAN 1 BLADEN

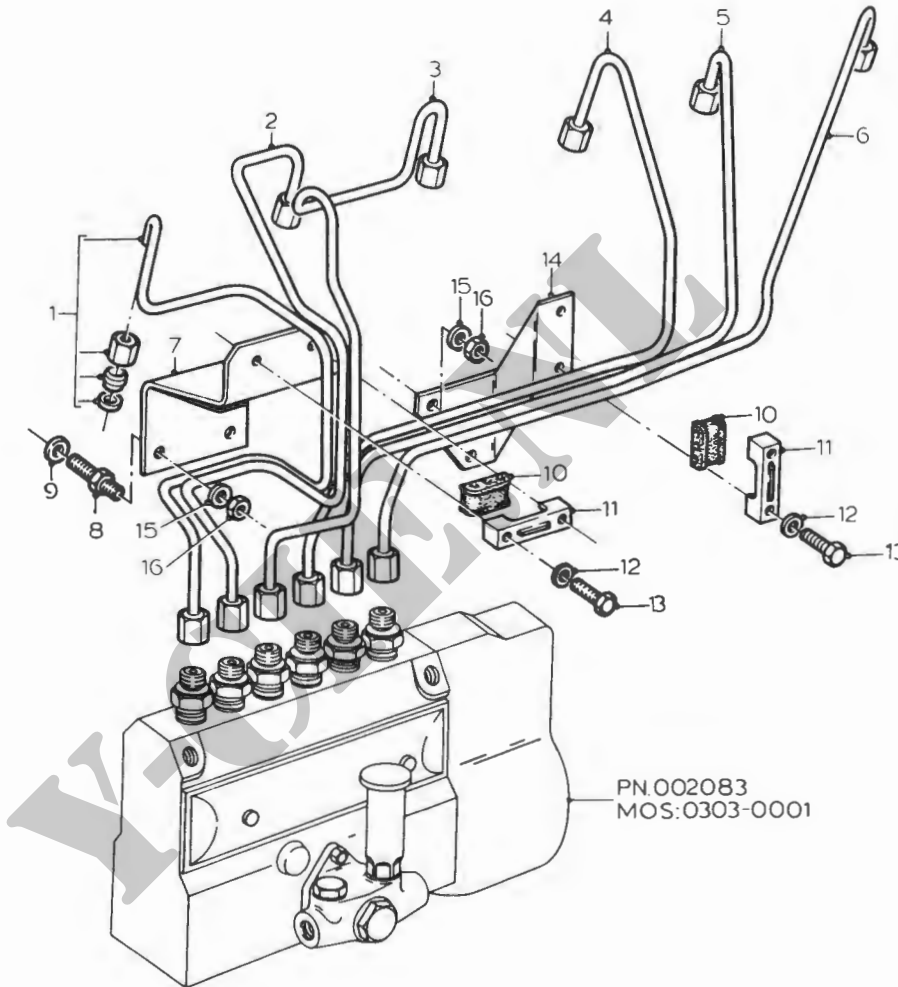
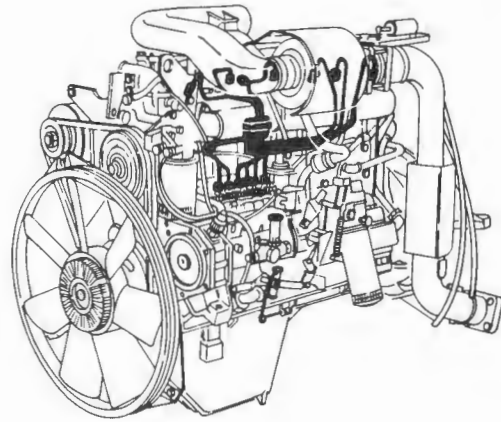

PN.002083  
MOS:0303-0001

0302-0002

PN 002083

MOSNR 0302-0002

INSPUITLEIDINGEN

DATUM: 890905 BLAD: 1

FIGNR	N MC	B	NSN	C	FCN	REFERENTIENUMMER (= FAN)	ARTIKELOMSCHRIJVING TOELICHTING	AANT ECH	OPMERKINGEN
1		B	4710-17-103-1572	8	H0001	0221579	PIJPSAMENSTEL, META	1 2	
2		B	4710-17-103-1573	9	H0001	0221580	PIJPSAMENSTEL, META	1 2	
3		B	4710-17-103-1574	0	H0001	0221581	PIJPSAMENSTEL, META	1 2	
4		B	4710-17-103-1575	0	H0001	0221582	PIJPSAMENSTEL, META	1 2	
5		B	4710-17-103-1576	1	H0001	0221583	PIJPSAMENSTEL, META	1 2	
6		B	4710-17-103-1577	2	H0001	0221584	PIJPSAMENSTEL, META	1 2	
8		B	5307-17-103-1530	0	H0001	0288468	TAPEIND, BORST-	4 2	
9		B	5365-17-024-2634	1	H0001	0215523	AFSTANDSTUK, RING	4 2	
10		B	2815-17-103-1564	0	H0001	0288395	BLOK, KLEM-	2 2	
11		B	2815-17-103-1565	1	H0001	0288396	BEUGEL, KLEM-	2 2	
12		B	5310-17-003-7547	9	H0001	0251912	ONDERLEGRING, VLAK	4 2	
13		B	5305-12-141-9848	0	H0001	0251615	SCHROEF, ZESKANTE KO	4 2	
					D8286	DIN933-M6X30-8.8-A2P			
15		B	5310-12-162-2131	4	H0001	0251928	ONDERLEGRING, BORG-	4 2	
					D8286	DIN128-A8			
16		B	5310-12-144-6214	0	H0001	0251275	MOER, ZESKANT	4 2	
					D8286	DIN934-M8-8-A2P			

PN 002083

INSPUITLEIDINGEN

MOSNR 0302-0002 BLAD: 1

23

-LAATSTE BLAD-

**YCHIE.ME**

**YCHIE.ME**

PROJECTNUMMER: 002083

MOSNUMMER : 0302-0003

BRANDSTOFLEIDINGEN EN LEKLEIDING OP MOTOR

DATUM 871102

BLAD 1 VAN 1 BLADEN

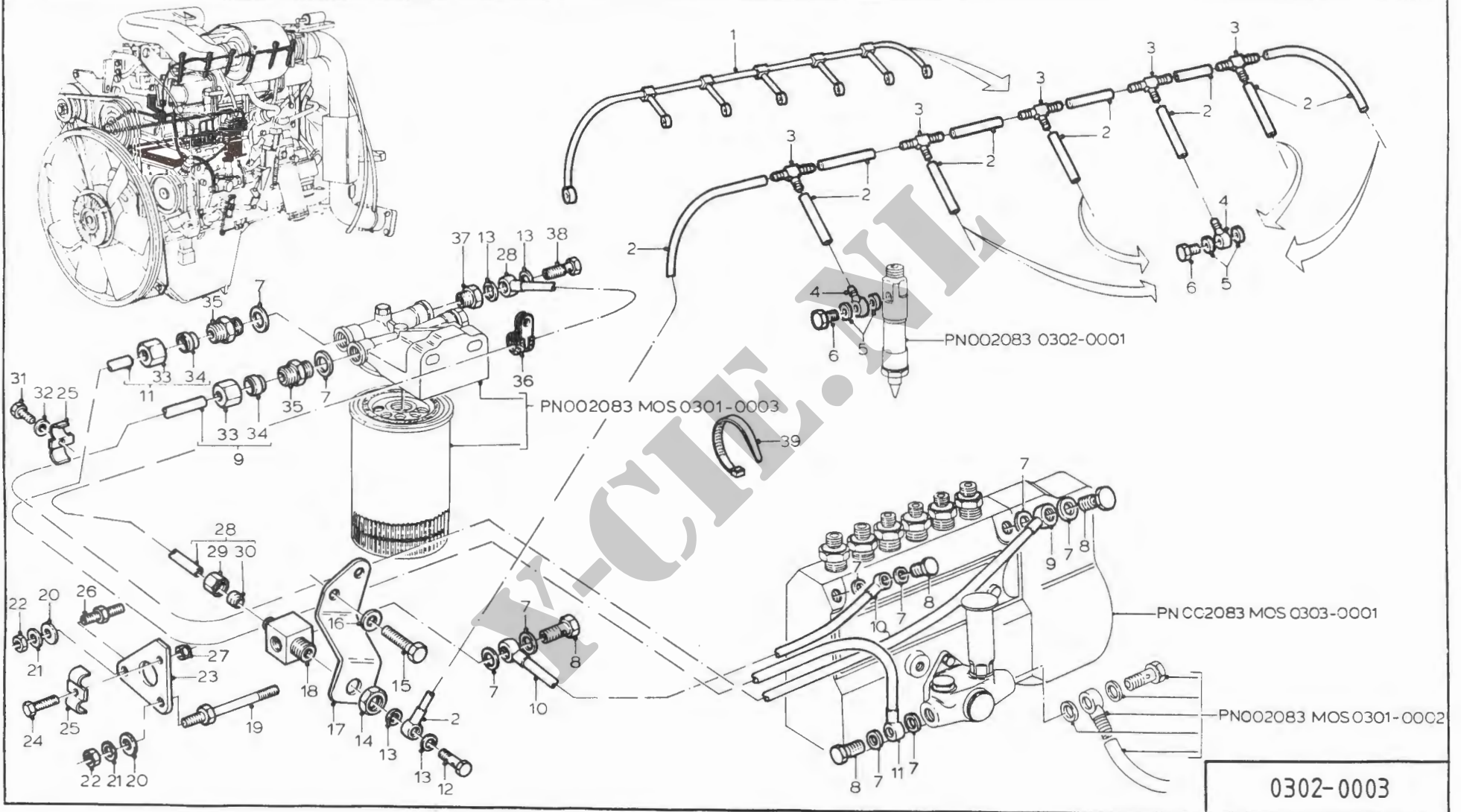

PN 002083

MOSNR 0302-0003

BRANDSTOF-EN LEKLEIDINGEN

DATUM: 890905

BLAD: 1

FIGNR	N MC	B	NSN	C	FCN	REFERENTIENUMMER (= FAN)	ARTIKELOMSCHRIJVING TOELICHTING	AANT ECH	OPMERKINGEN
1		B	4720-17-103-3907	0	H0001	0280625	SLANGSAMENSTEL, NIE	1 2	
2		B	4720-12-173-8647	8	H0001	0799007	PYP, NIET METAAL	NB 2	MR
					D8286	DIN73378-PA11WSWT-6X1			
3		B	0000-KL-041-4762	7	H0001	0286138	SLANGPILAAAR	5 2	
4		B	4730-17-054-4470	8	H0001	0668111	AANSLUITSTUK, MEERVO	6 2	
5		B	5330-12-156-4516	7	H0001	0373490	GASKET	12 2	
					D8286	DIN7603-A6X10-CU			
6		B	4730-12-196-6632	7	H0001	0661886	BOUT, BANJO	6 2	
					D8015	2433456020			
7		B	5330-12-156-4523	3	H0001	0244680	GASKET	3 2	
					D8286	DIN7603-A14X20-CU			
8		B	4730-12-124-1299	3	H0001	0240559	BOUT, BANJO	4 2	
					D8286	DIN7623-A8-6.8			
9		B	0000-KL-047-1930	8	H0001	0075696	LEIDING	1 2	DR
10		B	4710-17-103-3820	1	H0001	0892721	PIJPSAMENSTEL, META	1 2	
11		B	4710-17-103-3902	6	H0001	0075699	PYPSAMENSTEL, METAAL	1 2	
12		B	4730-17-706-1577	0	H0001	0211158	BOUT, BANJO	1 2	
13		B	5330-12-132-7079	5	D8286	DIN7603-A8X13-CU	GASKET	4 2	
14		B	5310-12-145-2077	0	H0001	0107233	MOER, ZESKANT	1 2	
15		B	5305-12-158-0033	3	H0001	0126721	SCHROEF, ZESKANTE KO	2 2	
					D8286	DIN933-M10X16-8.8-A3P			
16		B	5310-12-162-2130	3	H0001	0251929	ONDERLEGRING, BORG-	2 2	
					D8286	DIN128-A10			
17		B	4730-12-196-6632	7	H0001	0892731	BOUT, BANJO	1 2	
					D8015	2433456020			
18		B	4730-17-103-4424	0	H0001	0893098	KRUISSTUK, PUP	1 2	
20		B	5310-17-102-9967	9	H0001	0674026	ONDERLEGRING, VLAK	2 2	
21		B	5310-12-125-0066	3	H0001	0240528	ONDERLEGRING, VEER-	2 2	
					D8286	DIN137-B8			
22		B	5310-12-144-6214	0	H0001	0251275	MOER, ZESKANT	2 2	
					D8286	DIN934-M8-8-A2P			
24		B	5305-12-142-0188	0	D8286	DIN933-M6X22-8.8-A2P	SCHROEF, ZESKANTE KO	1 2	
25		B	5340-17-706-1578	1	H0001	0211902	BEUGEL, INSTALLATIE	2 2	
26		B	5307-17-103-1530	0	H0001	0288468	TAPEIND, BORST-	1 2	
27		B	5310-12-163-8840	4	H0001	0531419	MOER, ZELFBORGEND, ZE	1 2	
					D8286	DIN982-M6-8-A2P			
28		B	0000-KL-044-2367	2	H0001	0893431	LEIDING, BRANDSTOF-	1 2	
29		B	4730-12-132-5661	6	H0001	0226483	MOER, PYPKOPPELING	1 2	
30		B	4730-12-132-5660	5	H0001	0226480	HULS, INPERS-, PYPFIT	0302/0003/00028 1 2	

0302/0003/00028

PN 002083

BRANDSTOF-EN LEKLEIDINGEN

MOSNR 0302-0003

BLAD: 1

PN 002083

MOSNR 0302-0003

BRANDSTOF-EN LEKLEIDINGEN

DATUM: 890905

BLAD: 2

FIGNR	N	MC	B	NSN	C	FCN	REFERENTIENUMMER (= FAN)	ARTIKELOMSCHRIJVING TOELICHTING	AANT	ECH	OPMERKINGEN
31			B	5305-12-146-2633	6	H0001	0126718	SCHROEF, ZESKANTE KO	1	2	
						D8286	DIN933-M6X16-8.8-A2P				
32			B	5310-12-162-2129	2	H0001	0251927	ONDERLEGRING, BORG-	1	2	
						D8286	DIN128-A6-FST				
33			B	4730-12-123-4179	0	H0001	0146142	MOFR, PYPKOPPELING	2	2	
34			B	4730-12-137-6457	4	H0001	0146141	HULS, INPERS-, PYPFIT	2	2	
35			B	4730-17-102-9247	4	H0001	0113935	VERLOOPSTUK, STOMP	2	2	
36			B	5340-12-166-0529	1	H0001	0252391	KLEM, LUS	1	2	
						D8286	DIN3016-D1-6X20-W1-2				
37			B	0000-KL-044-2368	3	H0001	0892729	NIPPEL, VERLOOP-	2	2	
38			B	4730-12-124-1297	1	H0001	0253513	BOUT, BANJO	1	2	
						D8286	DIN7623-A2/3				
39			B	5975-00-074-2072	1	H0001	0261657	RIEM, BIND-, ELEKTRIS	1	2	
						H6869	TY25M				

PN 002083

BRANDSTOF-EN LEKLEIDINGEN

MOSNR 0302-0003 BLAD:

2

25

-LAATSTE BLAD-

Y-CHE.ME

PROJECTNUMMER: 002083

MOSNUMMER : 0303-0003

OPVOERPOMP

DATUM 871102

BLAD 1 VAN 1 BLADEN

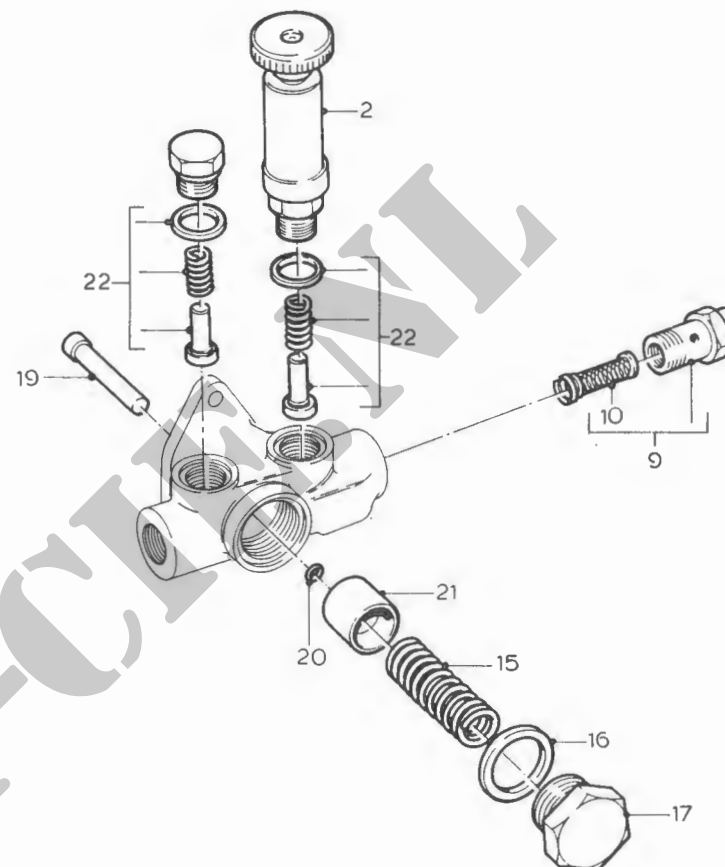
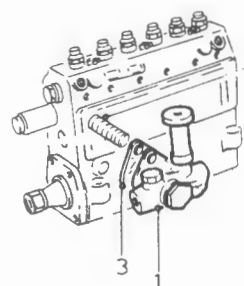

0303-0003

PN 002083

MOSNR 0303-0003

OPVOERPOMP

DATUM: 890905

BLAD: 1

FIGNR	N	MC	B	NSN	C	FCN	REFERENTIENUMMER (= FAN)	ARTIKELOMSCHRIJVING	TOELICHTING	AANT	ECH	OPMERKINGEN
1			B	2910-12-309-7894	7	H0001	0284918	POMP, HAND-		1	2	R
						D8015	0440003243					
2			B	2910-12-121-9958	2	H0001	0248559	POMP, ZUIGER, LINEAIR		1	2	SE
3			B	5330-12-141-8135	3	H0001	0242194	GASKET		1	2	
9			B	4730-12-161-8938	1	H0001	0505108	BOUT, BANJO		1	2	
						D8015	2443456900					

Y-CHE.ML

PN 002083

OPVOERPOMP

MOSNR 0303-0003

BLAD: 1

**KCH.ME**

**YCHIE.ME**

PROJECTNUMMER: 002083

MOSNUMMER : 0303-0004

VULDRUKREGELAAR

DATUM 871102

BLAD 1 VAN 1 BLADEN

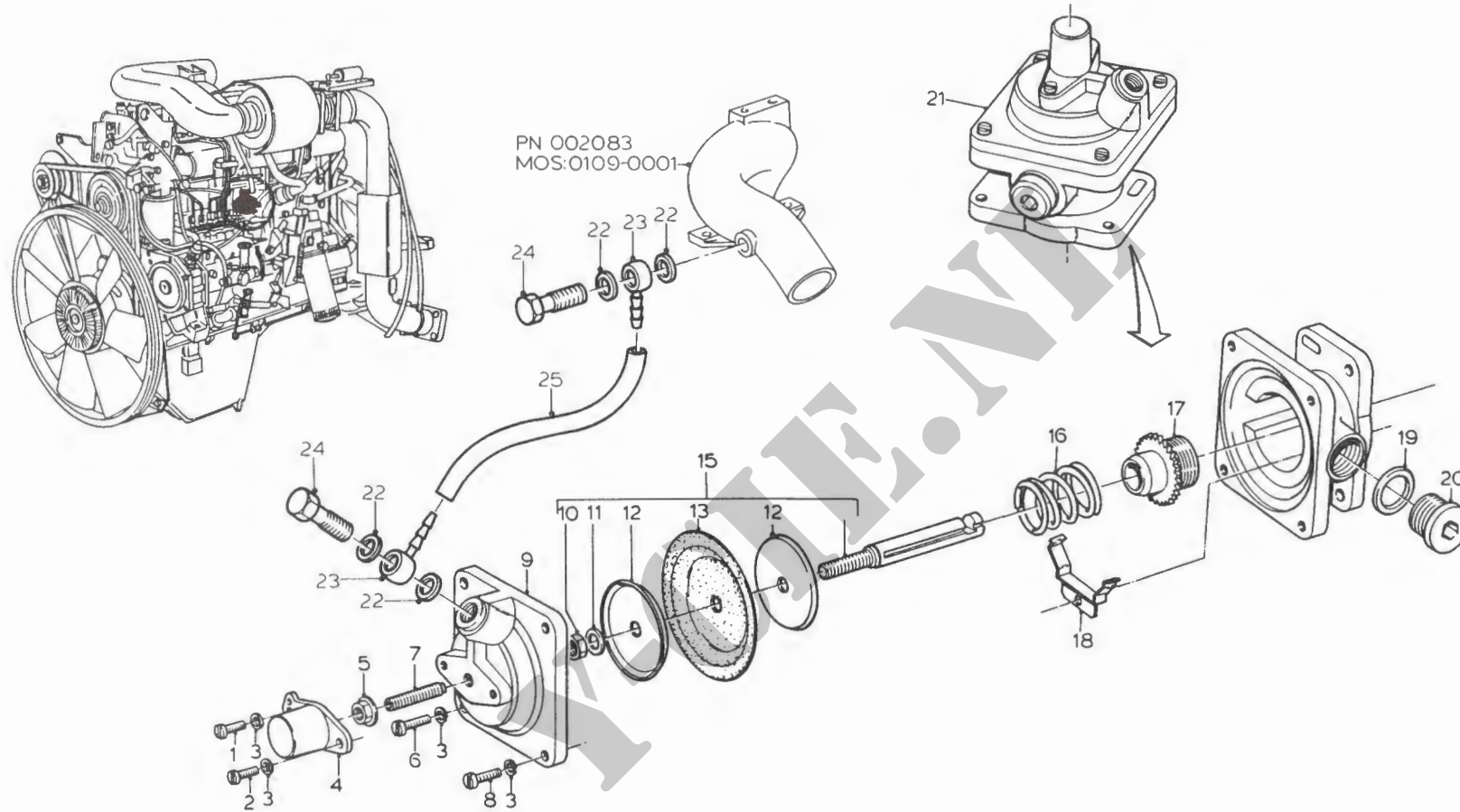

0303-0004

PN 002083

MOSNR 0303-0004

VULDRUKREGELAAR

DATUM: 890905

BLAD: 1

FIGNR	N	MC	B	NSN	C	FCN	REFERENTIENUMMER (= FAN)	ARTIKELOMSCHRIJVING TOELICHTING	AANT	ECH	OPMERKINGEN
22			B	5330-12-156-4805	0	H0001	0331328	GASKET	4	2	
						D8286	DIN7603-A12X17-CU				
23			B	0000-KL-042-2954	4	H0001	0629125	HUIS, BANJO-	2	2	
24			B	4730-12-124-1298	2	H0001	0243734	BOUT, BANJO	2	2	
						D8286	DIN7623-A6-6.8				
25			B	4720-12-317-5828	6	H0001	0799005	SLANG, NIET-METAAL	NB	2	MR
						D8286	DIN74324-10X1,25				

V-CHE.ME

PN 002083

VULDRUKREGELAAR

MOSNR 0303-0004 BLAD:

1

**Y-CHE.ME**

**Y-CHE.ME**

PROJECTNUMMER: 002083  
MOSNUMMER : 0304-0001

# GASBEDIENING,-STOPBEDIENING

DATUM 871102  
BLAD 1 VAN 2 BLADEN

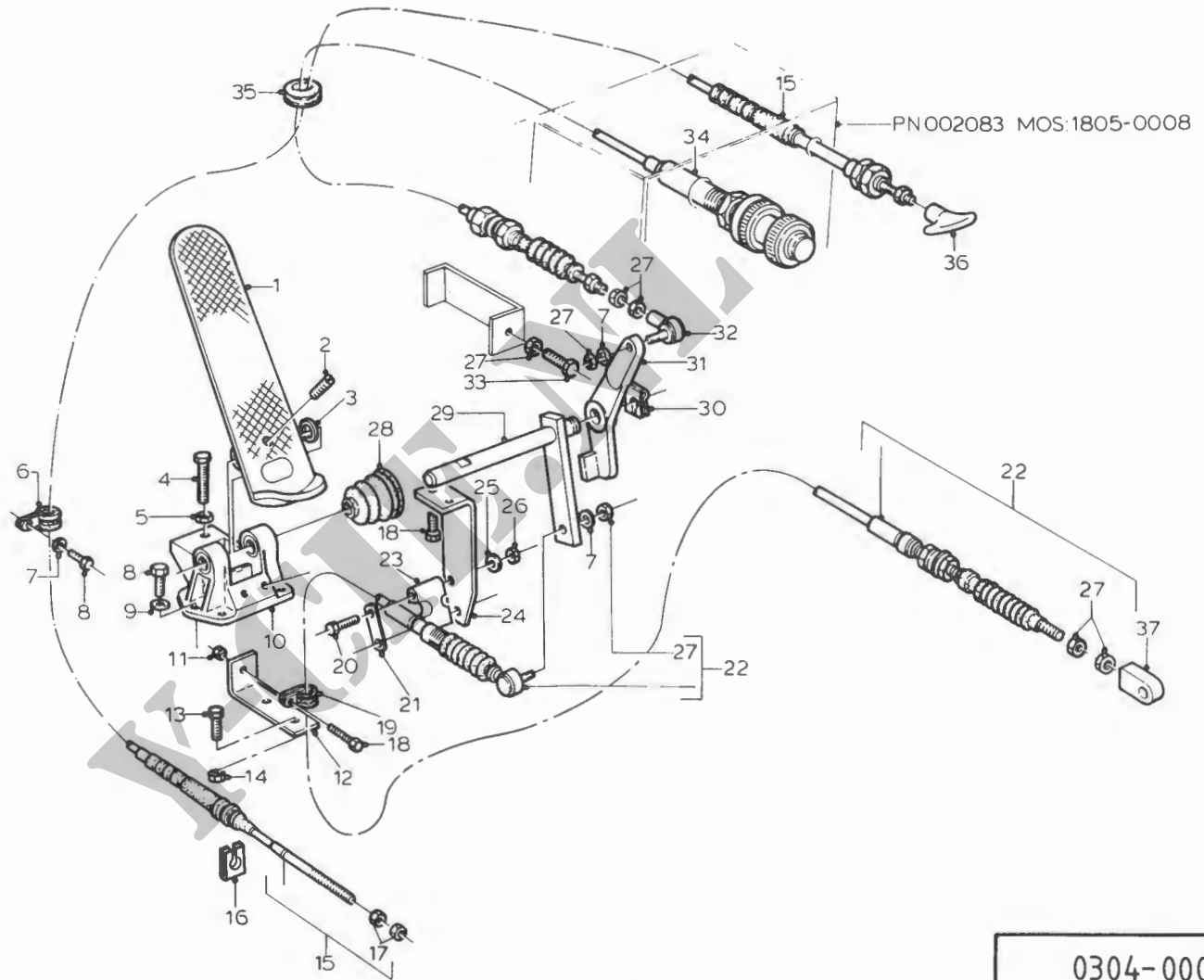
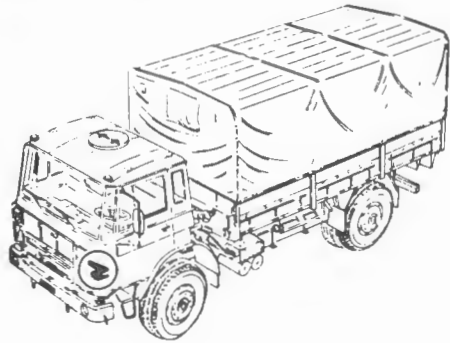

0304-0001

PN 002083

MOSNR 0304-0001

GASBEDIENING, -STOPBEDIENING

DATUM: 890905

BLAD: 1

FIGNR	N MC	B	NSN	C	FCN	REFERENTIENUMMER (= FAN)	ARTIKELOMSCHRIJVING TOELICHTING	AANT ECH	OPMERKINGEN
2		B	0000-KL-044-1053	8	H0001	0740634	STELSCHROEF	1 2	
					D8286	DIN914-M8X16X11X12.9			
3		B	5310-12-136-4120	9	H0001	0252985	ONDERLEGRING, BORG	2 2	
					D8286	DIN137-B12-A2A			
4		B	5305-12-141-9872	2	H0001	0251626	SCHROEF, ZESKANTE KO	1 2	
					D8286	DIN933-M8X40-8.8-A2P			
5		B	5310-12-144-6214	0	H0001	0251275	MOER, ZESKANT	1 2	
					D8286	DIN934-M8-8-A2P			
6		B	5340-12-159-4286	0	H0001	0241801	KLEM, LUS	1 2	
					D8286	DIN3016-D1-6X15-W1-2			
7		B	5310-12-162-2129	2	H0001	0251927	ONDERLEGRING, BORG-	3 2	
					D8286	DIN128-A6-FST			
8		B	5305-12-146-2633	6	H0001	0126718	SCHROEF, ZESKANTE KO	4 2	
					D8286	DIN933-M6X16-8.8-A2P			
9		B	5310-12-142-8171	7	H0001	0310268	VEERRING, ENKEL	3 2	
					D8286	DIN137-B6-A3P			
11		B	5310-17-915-1029	2	H0001	0272563	MOER, KRAAG, ZESKANT	1 2	
					D8286	DIN6923-M6-8-A2P			
13		B	5306-12-317-5568	0	H0001	0268977	BOUT, MACHINE	1 2	
					D8286	DIN6921-M8X20-8.8-A2P			
14		B	5310-17-915-1028	1	H0001	0268985	MOER, FLENS-	1 2	
					D8286	DIN6923-M8X17,9X8X13X8			
15		B	2990-17-102-9977	8	H0001	0392082	BEDIENINGSSAMENSTEL	1 2	
16		B	5365-12-166-4869	7	H0001	0247724	RING, BORG-, VEREND	1 2	
					D9414	12SXX09			
17		B	5310-12-199-0650	1	H0001	0372225	MOER, ZESKANT	2 2	
					D8286	DIN936-M12X1-05-A2P			
18		B	5306-17-910-8562	6	H0001	0272322	BOUT, FLENS-	3 2	
19		B	5340-12-143-0054	9	H0001	0241312	KLEM, LUS	1 2	
					D8286	DIN3016-D1-10X15-W1-2			
20		B	5305-12-142-8430	2	H0001	0367645	SCHROEF, ZESKANTE KO	2 2	
					D8286	DIN931-M5X40-8.8-A2P			
22		B	2990-17-102-9978	9	H0001	0392081	BEDIENINGSSAMENSTEL	1 2	R
23		B	2815-17-103-1566	2	H0001	0367925	BLOK, BEVESTIGINGS-	1 2	
25		B	5310-12-189-1721	6	H0001	0251926	ONDERLEGRING, BORG-	2 2	
					D8286	DIN128-A5			
26		B	5310-12-156-4990	8	H0001	0251273	MOER, ZESKANT	2 2	
					D8286	DIN934-M5-8-A2P			
27		B	5310-12-156-4991	9	H0001	0251274	MOER, ZESKANT	4 2	
					D8286	DIN934-M6-8-A2P			

0304/0001/00015

PN 002083

GASBEDIENING, -STOPBEDIENING

MOSNR 0304-0001 BLAD:

1

FIGNR	N MC	B	NSN	C	FCN	REFERENTIENUMMER (= FAN)	ARTIKELOMSCHRIJVING	TOELICHTING	AANT	ECH	OPMERKINGEN
28		B	9320-17-049-5014	8	H0001	0240918	BALG, BESCHERM-		1	2	
29		B	2815-17-103-1555	2	H0001	0740544	ASSAMENSTEL, GASBED		1	2	
30		B	5340-17-910-6849	9	H0001	0286053	BORGCLIP		1	2	
						D9414	12SXN06				
32		B	3040-17-103-1542	0	H0001	0376770	KOGELGEWRIJCHT		1	2	
33		B	5305-12-141-9849	1	H0001	0251616	SCHROEF, ZESKANTE KO		1	2	
						D8286	DIN933-M6X35-8.8-A2P				
34		B	2990-17-102-9979	0	H0001	0392083	BEDIENINGSSAMENSTEL		1	2	
35		B	5325-17-043-6120	8	H0001	0891405	TULE, RUBBER		1	2	
36		B	5355-17-055-7454	1	H0001	0273354	KNOP		1	2	
37		B	2815-17-103-2043	6	H0001	0377957	HEI BOOM		1	2	
38		B	3040-17-103-1542	0	H0001	0376770	KOGELGEWRIJCHT		1	2	
39		B	5365-17-024-2634	1	H0001	0215523	AFSTANDSTUK, RING		3	2	
40		B	5307-17-103-1530	0	H0001	0288468	TAPEIND, BORST-		3	2	
42		B	5305-12-141-9852	4	D8286	DIN933-M6X50-8.8-A2P	SCHROEF, ZESKANTE KO		3	2	
43		B	5365-17-054-3453	3	H0001	0636134	AFSTANDSTUK, BUS		1	2	
44		B	5310-12-162-2131	4	H0001	0251928	ONDERLEGRING, BORG-		4	2	
						D8286	DIN128-A8				
47		B	5310-12-148-5159	4	H0001	0251282	MOER, ZESKANT		2	2	
						D8286	DIN439-BM6-05-A2P				
48		B	5310-17-003-7547	9	H0001	0251912	ONDERLEGRING, VLAK		3	2	
49		B	0000-KL-041-0074	5	H0001	0365036	LAGER		2	2	
						D2456	608.2RSR				
50		B	5310-12-145-5250	4	H0001	0251913	ONDERLEGRING, VLAK		2	2	
						D8286	DIN433-8,4-ST-A3P				
58		B	5310-12-142-0644	4	D8286	DIN125-B6,4-ST-A3P	ONDERLEGRING, VLAK		2	2	
62		B	5310-12-142-0644	4	H0001	0251904	ONDERLEGRING, VLAK		1	2	
						D8286	DIN125-B6,4-ST-A3P				
63		B	5310-12-163-8840	4	H0001	0531419	MOER, ZELFBORGEND, ZE		1	2	
						D8286	DIN982-M6-8-A2P				
65		B	5340-12-177-4346	1	H0001	0559346	KLEM, VEER-		1	2	
						D9414	6SXN08				
67		B	0000-KL-041-0086	6	H0001	0384368	NIPPEL, KABELBORG-		1	2	
69		B	5305-12-156-4865	4	H0001	0251623	SCHROEF, ZESKANTE KO		1	2	
						D8286	DIN933-M8X25-8.8-A2P				

**YCHIE.ME**

PROJECTNUMMER: 002083  
MOSNUMMER : 0501-0001

RADIATEUR ,EXPANSIETANK

DATUM 871102  
BLAD 1 VAN 1 BLADEN

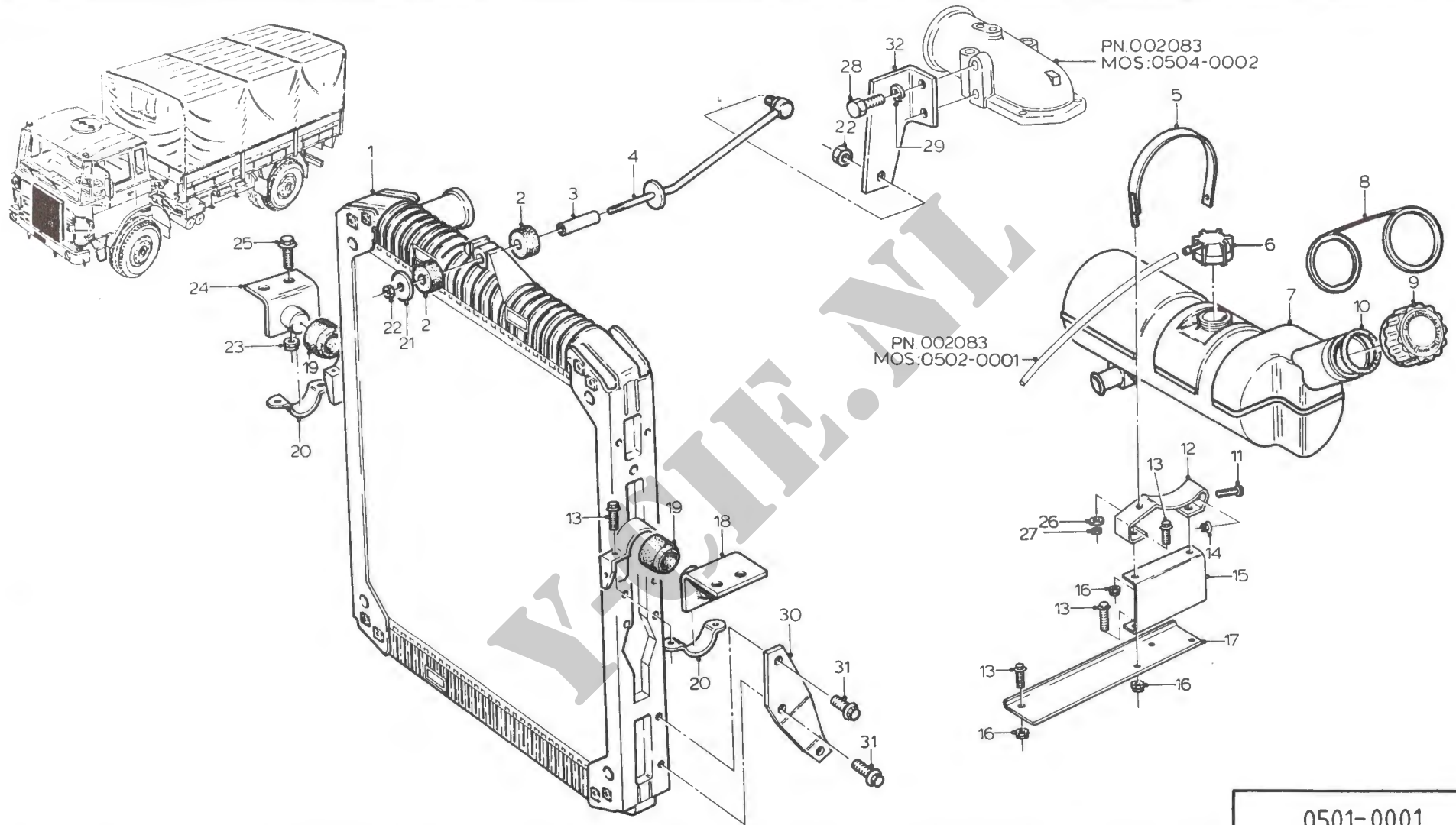

PN 002083

MOSNR 0501-0001

RADIATEUR, EXPANSIETANK

DATUM: 890905

BLAD: 1

FIGNR	N MC	B	NSN	C	FCN	REFERENTIENUMMER (= FAN)	ARTIKELOMSCHRIJVING TOELICHTING	AANT ECH	OPMERKINGEN
2		B	5365-17-103-2363	7	H0001	0377347	AFSTANDSTUK, BUS	2 2	
4		B	5306-17-103-1556	3	H0001	0398914	STANG, GEGROEFD, ZO	1 2	
5		B	5340-17-103-4238	1	H0001	0086241	BAND, KLEM-	2 2	
6		B	0000-KL-041-4541	6	H0001	0278458	DEKSEL, BUFFERVAT-	1 2	
7		B	2815-17-103-1588	2	H0001	0397094	TANK, KOELWATER-	1 2	
8		B	2930-17-103-4367	9	H0001	0701962	BAND, BEV.	1 2	
9		B	2815-17-102-9984	4	H0001	0084511	DOP, VULOPENING	1 2	
10		B	5330-17-102-9981	1	H0001	0375212	PAKKING, VOORGEVORM	1 2	
11		B	5306-17-910-8562	6	H0001	0272322	BOUT, FLENS-	2 2	
13		B	5306-12-317-5568	0	H0001	0268977	BOUT, MACHINE	10 2	
14		B	5310-17-915-1029	2	H0001	0272563	MOER, KRAAG, ZESKANT	2 2	
16		B	5310-17-915-1028	1	H0001	0268985	MOER, FLENS-	12 2	
19		B	5365-17-102-9982	2	H0001	0516579	AFSTANDSTUK, BUS	2 2	
21		B	5310-17-103-1538	7	H0001	0377783	ONDERLEGRING, VLAK	1 2	
22		B	5310-12-167-1881	1	D8286	DIN982-M8-8-A2P	MOER, ZELFBORGEND, ZE	1 2	
23		B	0000-KL-040-5698	7	H0001	0645165	MOER, FLENS-METR. GLA	1 2	
25		B	5306-17-103-1539	8	H0001	0290128	BOUT, GEASSEMBLEERD	4 2	
26		B	5310-17-003-7547	9	H0001	0251912	ONDERLEGRING, VLAK	2 2	
27		B	5310-12-163-8840	4	H0001	0531419	MOER, ZELFBORGEND, ZE	2 2	
28		B	5305-12-155-6878	3	H0001	0126720	SCHROEF, ZESKANTE KO	2 2	
29		B	5310-12-162-2131	4	H0001	0251928	ONDERLEGRING, BORG-	2 2	
31		B	5305-12-155-6878	3	H0001	0376966	SCHROEF, ZESKANTE KO	2 2	

PN 002083

RADIATEUR, EXPANSIETANK

MOSNR 0501-0001 BLAD: 1

30

-LAATSTE BLAD-

YCHIE.ME

van Hest  
Jan de Roc  
5171 DR K  
G.L.  
rast 9  
thruvel

**YCHIE.ME**

PROJECTNUMMER: 002083  
MOSNUMMER : 0504-0001

KOELWATERPOMP KPL.

DATUM 871102  
BLAD 1 VAN 1 BLADEN

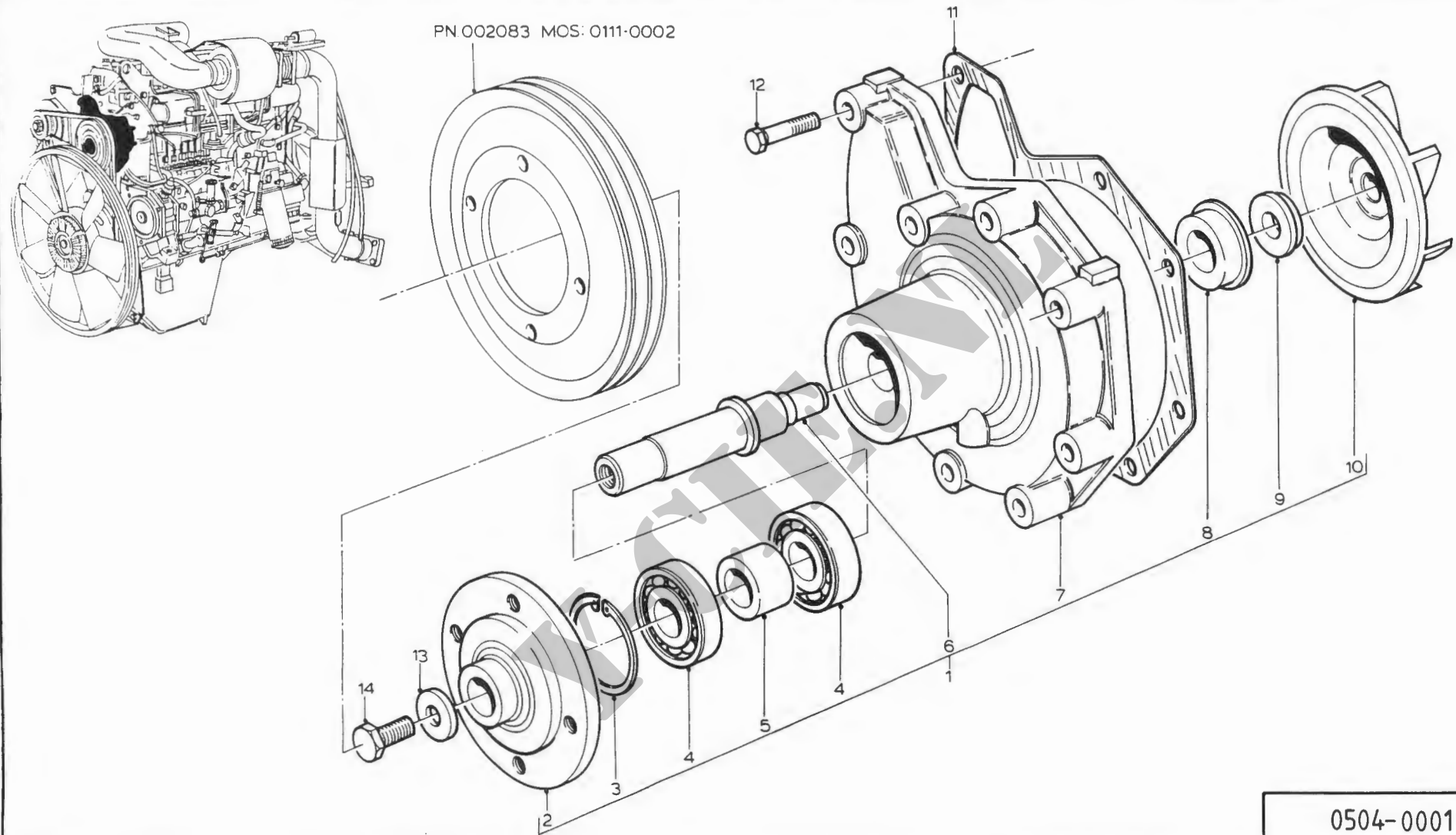

0504-0001

PN 002083

MOSNR 0504-0001

KOELWATERPOMP KPL

DATUM: 890905 BLAD: 1

FIGNR	N	MC	B	NSN	C	FCN	REFERENTIENUMMER (= FAN)	ARTIKELOMSCHRIJVING TOELICHTING	AANT ECH	OPMERKINGEN
11			B	5330-17-103-1590	4	H0001	0677181	GASKET	1	2
12			B	5306-17-103-2451	7	H0001	0635770	BOUT, MACHINE	8	2
						H0001	M8X40X8X2DAFN9279			

0504/0003/00001

YCHIE.ML

PN 002083

KOELWATERPOMP KPL

MOSNR 0504-0001 BLAD: 1

31

-LAATSTE BLAD-

**Y-CHE.ME**

**KCH.ME**

PROJECTNUMMER: 002083

MOSNUMMER : 0504-0002

THERMOSTATEN

DATUM 871102

BLAD 1 VAN 1 BLADEN

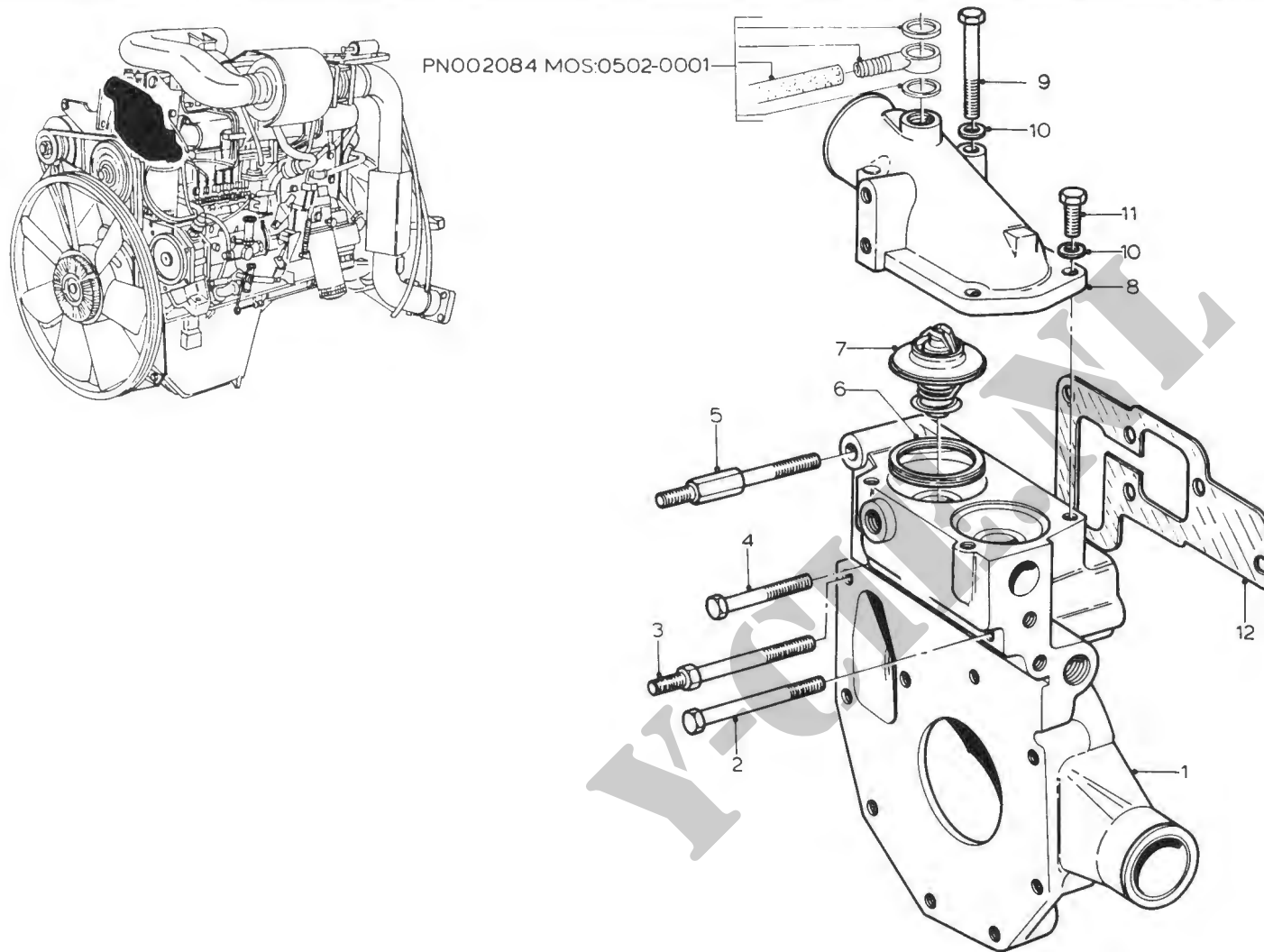

0504-0002

PN 002083

MOSNR 0504-0002

THERMOSTATEN

DATUM: 890905

BLAD: 1

FIGNR	N MC	B	NSN	C	FCN	REFERENTIENUMMER (= FAN)	ARTIKELOMSCHRIJVING TOELICHTING	AANT ECH	OPMERKINGEN
2		B	5305-12-156-4950	1	H0001	0251491	SCHROEF,ZESKANTE KO	3 2	
					D8286	DIN931-M8X80-8.8-A2P			
3		B	5307-17-103-1540	9	H0001	0220149	TAPEIND,BORST-	1 2	
4		B	5305-12-156-4949	0	D8286	DIN931-M8X55-8.8-A2P	SCHROEF,ZESKANTE KO	1 2	
5		B	5307-17-103-1541	0	H0001	0220147	TAPEIND,BORST-	1 2	
6		B	5330-17-034-1039	0	H0001	0240953	PAKKINGRING	2 2	
7		B	6680-12-317-9130	8	H0001	0672276	THERMOSTAAT,VLOEIST	2 2	
					D9093	1132791009K			
9		B	5305-12-141-6606	3	H0001	0251487	SCHROEF,ZESKANTE KO	1 2	
					D8286	DIN931-M8X60-8.8-A2P			
10		B	5310-12-125-0066	3	H0001	0240528	ONDERLEGRING,VEER-	3 2	
					D8286	DIN137-B8			
11		B	5305-12-156-4863	2	H0001	0251621	SCHROEF,ZESKANTE KO	2 2	
					D8286	DIN933-M8X20-8.8-A2P			
12		B	5330-17-103-3984	0	H0001	0527153	GASKET	1 2	

PN 002083

THERMOSTATEN

MOSNR 0504-0002 BLAD: 1

32

-LAATSTE BLAD-

**Y-CHE.ME**

Y-CHE.ME



PN 002083

MOSNR 0505-0001

WINDTUNNEL, MANCHET

DATUM: 890905

BLAD: 1

FIGNR	N	MC	B	NSN	C	FCN	REFERENTIENUMMER (= FAN)	ARTIKELOMSCHRIJVING TOELICHTING	AANT ECH	OPMERKINGEN
2			B	5330-17-103-1567	3	H0001	0365226	HOES, AFDICHT-	1	2
5			B	5310-17-915-1028	1	H0001	0268985	MOER, FLENS-	5	2
						D8286	DIN6923-M8X17,9X8X13X8			
6			B	5305-17-103-0050	4	H0001	0362030	SCHROEF, ZESKANT KOP	4	2
10			B	5305-12-156-4860	0	H0001	0251610	SCHROEF, ZESKANTE KO	6	2
						D8286	DIN933-M6X12-8.8-A2P			
11			B	5310-12-142-0644	4	D8286	DIN125-B6,4-ST-A3P	ONDERLEGRING, VLAK	6	2
12			B	5305-12-155-6878	3	H0001	0376966	SCHROEF, ZESKANTE KO	4	2
						D8286	DIN6921-M8X16-8.8-A2P			
14			B	5310-12-125-0066	3	H0001	0240528	ONDERLEGRING, VEER-	6	2
						D8286	DIN137-B8			
15			B	5310-12-144-6214	0	H0001	0251275	MOER, ZESKANT	6	2
						D8286	DIN934-M8-8-A2P			

PN 002083

WINDTUNNEL, MANCHET

MOSNR 0505-0001 BLAD: 1

**KCH.ME**

Y-CHE.ME

PROJECTNUMMER: 002083  
MOSNUMMER : 0601-0001

DYNAMO

DATUM 871102  
BLAD 1 VAN 1 BLADEN

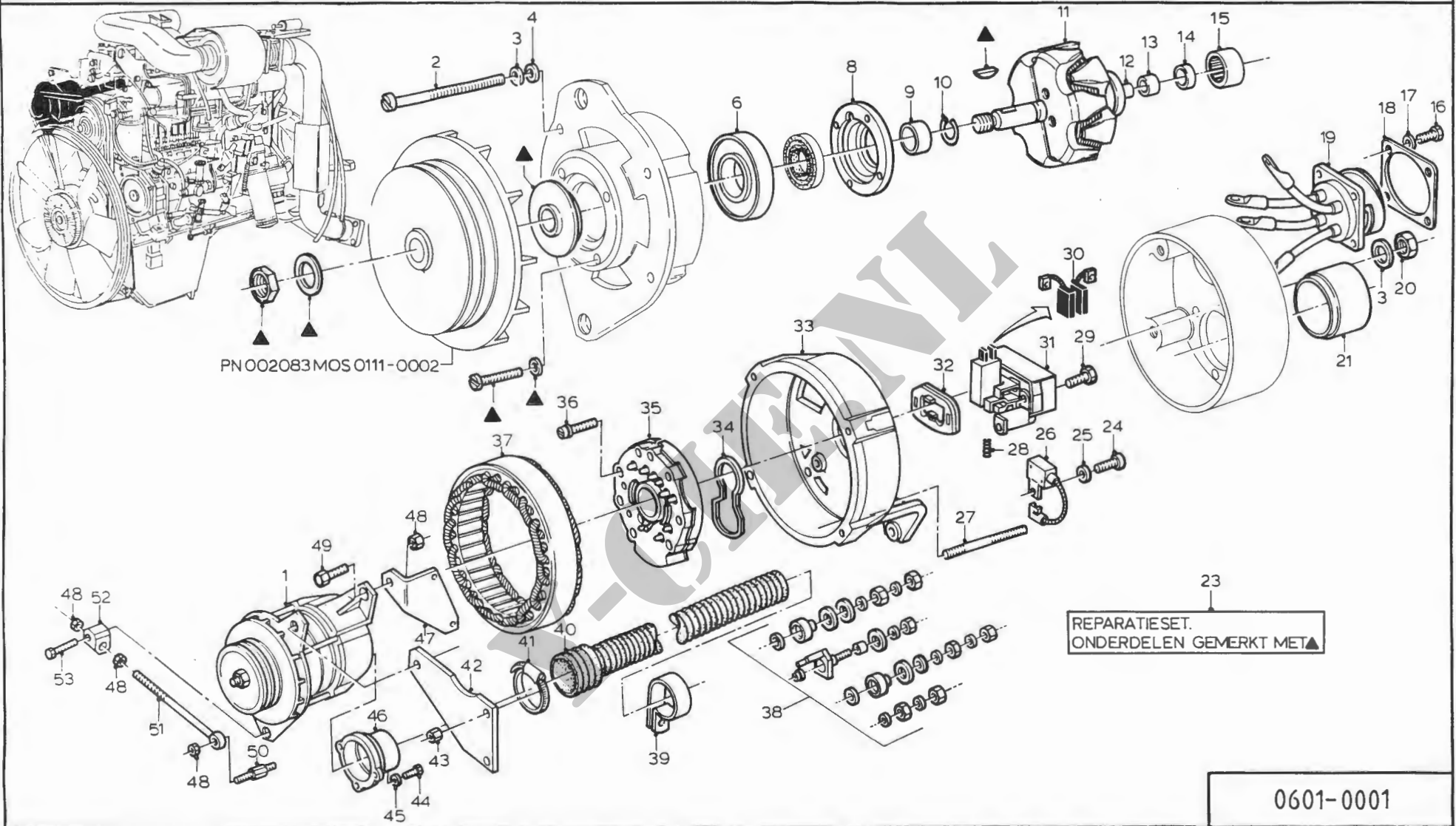

PN 002083

MOSNR 0601-0001

DYNAMO

DATUM: 890905

BLAD: 1

FIGNR	N	MC	B	NSN	C	FCN	REFERENTIENUMMER (= FAN)	ARTIKELOMSCHRIJVING TOELICHTING	AANT ECH	OPMERKINGEN
1			B	6115-17-102-7909	8	H0001	0681893	GENERATOR, WISSELSTR	1 2	DR
23			B	5940-17-911-0458	0	H0001	0696015	SET MONTAGE	1 2	
40			B	4720-17-103-2432	0	H0001	0388401	SLANG, LUCHTCIRCULAT	1 2	
41			B	4730-12-161-7555	4	H0001	0668679	KLEM, SLANG	1 2	
43			B	5310-12-144-6214	0	H0001	D8286 DIN3017-AS60-80C8-W5 0251275	MOER, ZESKANT	4 2	
44			B	5305-12-146-2633	6	H0001	D8286 DIN934-M8-8-A2P 0126718	SCHROEF, ZESKANTE KO	3 2	
48			B	5310-12-156-4982	0	H0001	D8286 DIN933-M6X16-8.8-A2P 0251277	MOER, ZESKANT	6 2	
49			B	5305-12-156-4878	6	H0001	D8286 DIN934-M12-8-A2P 0119148	SCHROEF, ZESKANTE KO	2 2	
50			B	5307-17-103-2433	0	H0001	D8286 DIN933-M12X40-8.8-A3P 0220108	TAPE IND, BORST-	1 2	
51			B	5306-12-318-0414	5	H0001	0637028 D8286 DIN444-BM12X160-8.8-A3P	BOUT, OOG	1 2	**
52			B	2815-17-103-2434	1	H0001	0285118	BLOK, BEVESTIGINGS-	1 2	
53			B	5305-12-142-8265	2	H0001	0251507 D8286 DIN931-M12X55-8.8-A3P	SCHROEF, ZESKANTE KO	1 2	

PN 002083

DYNAMO

MOSNR 0601-0001 BLAD: 1

**YCHIE.ME**

**YCHIE.ME**

PROJECTNUMMER: 002083  
MOSNUMMER : 0603-0001

# BATTERIJHOUDER

DATUM 871102  
BLAD 1 VAN 1 BLADEN

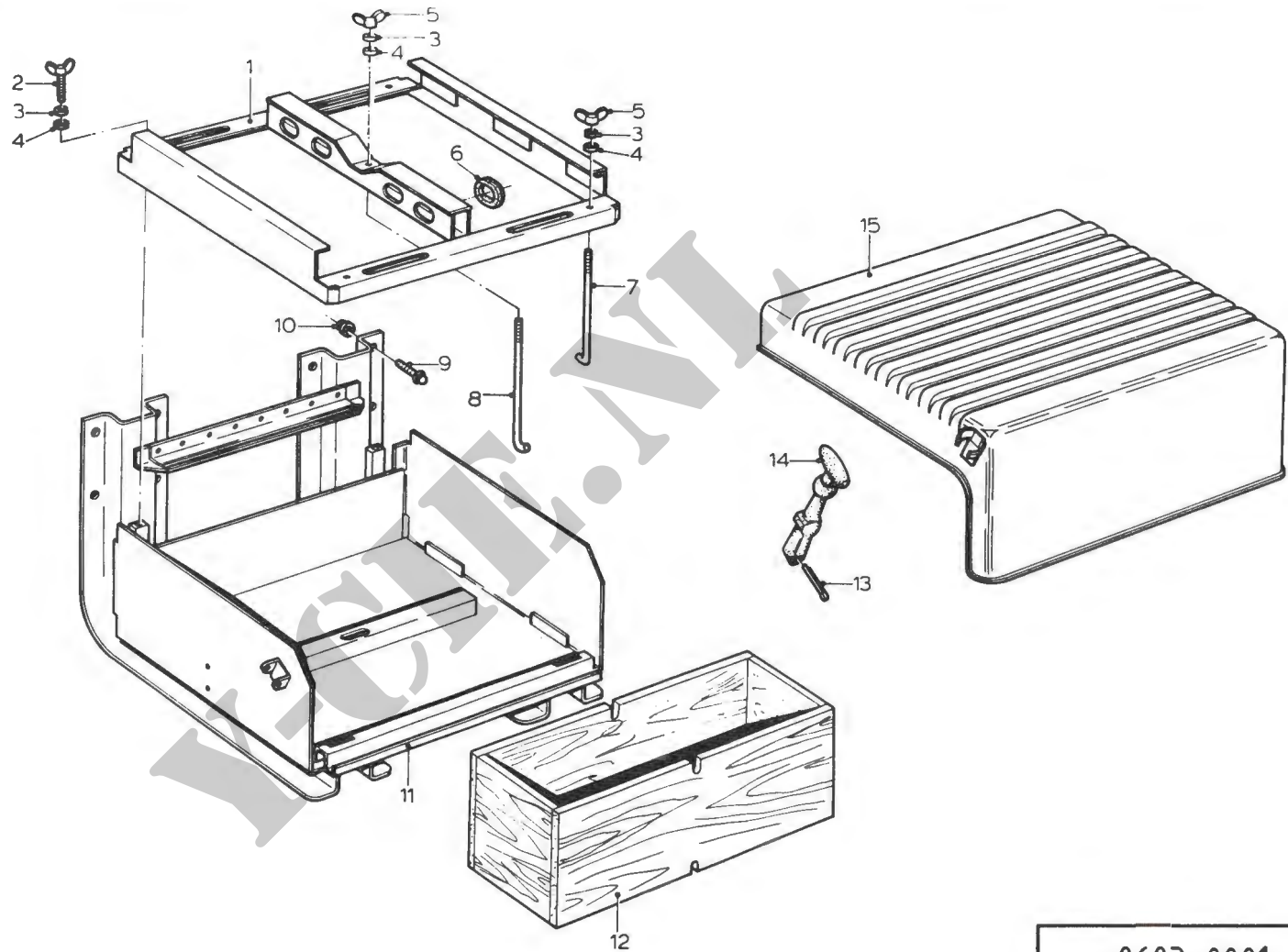
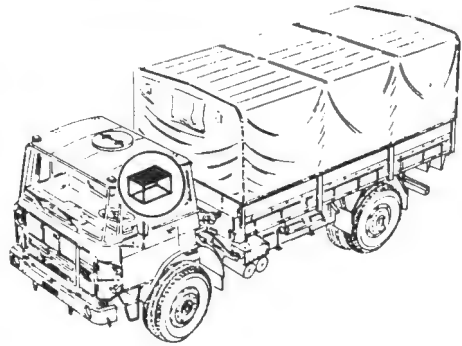

0603-0001

PN 002083

MOSNR 0603-0001

BATTERIJHOUDER

DATUM: 890905

BLAD: 1

FIGNR	N	MC	B	NSN	C	FCN	REFERENTIENUMMER (= FAN)	ARTIKELOMSCHRIJVING	TOELICHTING	AANT	ECH	OPMERKINGEN
2			B	0000-KL-041-0170	2	H0001	0220310	BOUT, VLEUGEL-		2	2	
						D8286	DIN316-M8X55-ST-A3P					
3			B	5310-12-125-0066	3	H0001	0240528	ONDERLEGRING, VEER-		5	2	
						D8286	DIN137-B8					
4			B	5310-12-149-4353	2	H0001	0325421	ONDERLEGRING, VLAK		5	2	
						D8286	DIN125-A8, 4-ST-A3P					
5			B	5310-12-143-0040	6	H0001	0251380	MOER, VLEUGEL		3	2	
						D8286	DIN315-M8-MG-5-A2P					
6			B	5325-17-015-8730	5	H0001	0139912	TULE, RUBBER		4	2	
7			B	0000-KL-041-0171	3	H0001	0392734	STANG, TREK- ACCUBAK		2	2	
8			B	0000-KL-041-0172	4	H0001	0392735	STANG, TREK- ACCUBAK		1	2	
9			B	5306-17-050-8004	7	H0001	0638044	BOUT, MACHINE		8	2	
10			B	5310-17-050-7984	9	H0001	0638050	MOER, KRAAG, ZESKANT		8	2	
13			B	5315-12-197-6054	2	H0001	0251878	PEN, SPLIT		2	2	
						D8286	DIN94-5X71-ST-ZNPHR10F					
14			B	2540-12-121-2104	2	D8905	602 0024	KNEVEL		2	2	

PN 002083

BATTERIJHOUDER

MOSNR 0603-0001 BLAD: 1

-LAATSTE BLAD-

**KCH.ME**

Y-CHE.ME

PROJECTNUMMER: 002083

MOSNUMMER : 0603-0002

# BATTERIJKABELS

DATUM 871102

BLAD 1 VAN 1 BLADEN

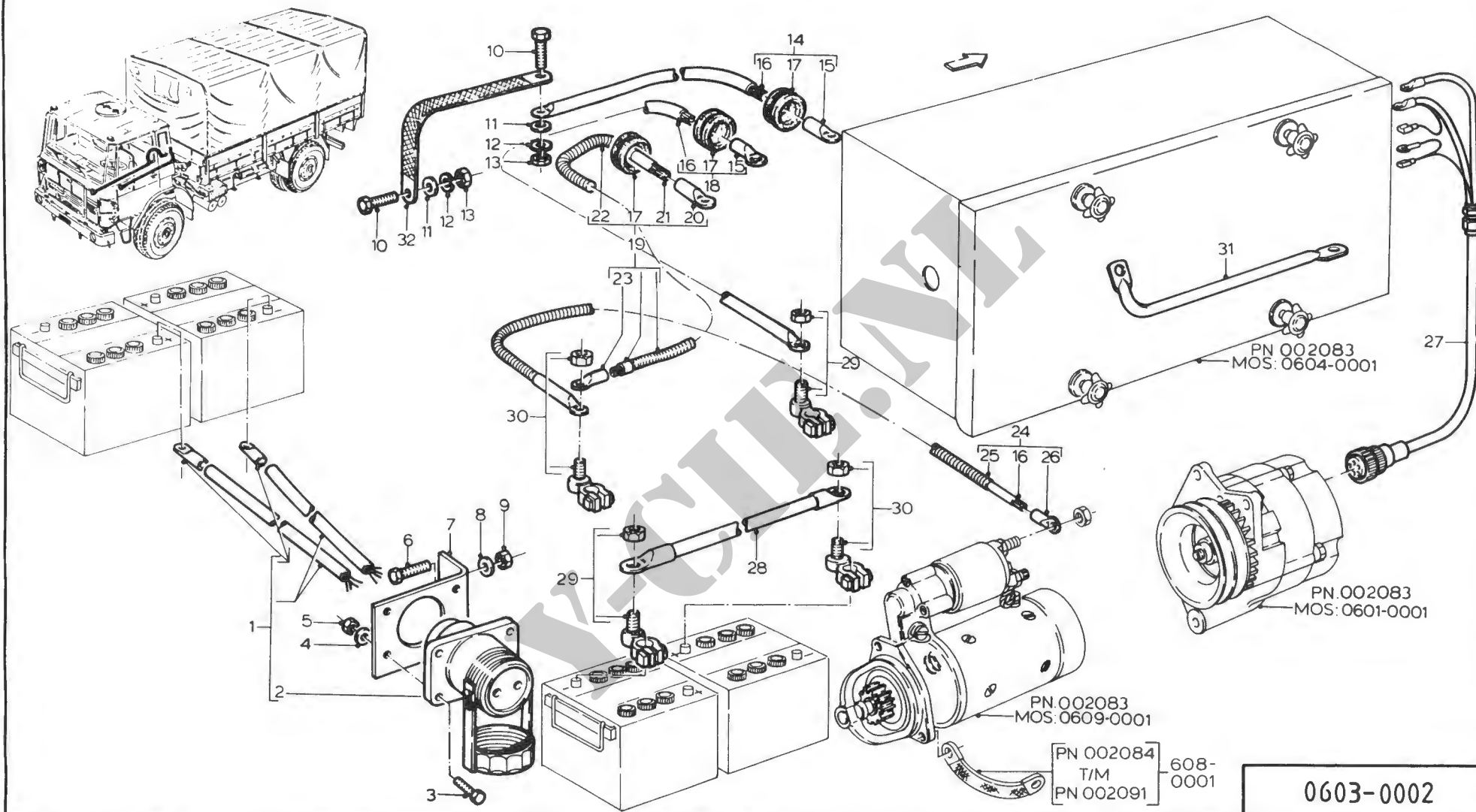

0603-0002

PN 002083

MOSNR 0603-0002

BATTERIJKABELS

DATUM: 890905 BLAD: 1

FIGNR	N MC	B	NSN	C	FCN	REFERENTIENUMMER (= FAN)	ARTIKELOMSCHRIJVING TOELICHTING	AANT ECH	OPMERKINGEN
1		B	5935-17-103-2435	2	H0001	0590530	CONNECTOR, DOOS, EL.	1 2	
2		B	5935-00-295-6403	0	H0001	0305043	CONNECTOR, DOOS, ELEK	1 2	
					H0711	TVA9999-2-3-054			
3		B	5305-12-156-4862	1	H0001	0251612	SCHROEF, ZESKANTE KO	4 2	0603/0002/00001
					D8286	DIN933-M6X20-8.8-A2P			
4		B	5310-12-162-2129	2	H0001	0251927	ONDERLEGRING, BORG-	4 2	
					D8286	DIN128-A6-FST			
5		B	5310-12-156-4991	9	H0001	0251274	MOER, ZESKANT	4 2	
					D8286	DIN934-M6-8-A2P			
6		B	5305-12-156-4865	4	H0001	0251623	SCHROEF, ZESKANTE KO	2 2	
					D8286	DIN933-M8X25-8.8-A2P			
8		B	5310-12-124-0892	3	H0001	0251939	ONDERLEGRING, BORG-	2 2	
					D8286	DIN6798-A8, 4			
9		B	5310-12-144-6214	0	H0001	0251275	MOER, ZESKANT	2 2	
					D8286	DIN934-M8-8-A2P			
10		B	5305-12-156-4858	8	H0001	0251635	SCHROEF, ZESKANTE KO	2 2	
					D8286	DIN933-M10X35-8.8-A3P			
11		B	5310-12-142-0481	6	D8286	DIN125-B10, 5-ST-A3P	ONDERLEGRING, VLAK	2 2	
12		B	5310-12-162-2130	3	H0001	0251929	ONDERLEGRING, BORG-	2 2	
					D8286	DIN128-A10			
13		B	5310-12-156-4996	3	H0001	0251276	MOER, ZESKANT	2 2	
					D8286	DIN934-M10-8-A2P			
14		B	2590-17-103-2436	3	H0001	0556469	DRAADSAMENSTEL, ELEK	1 2	R
17		B	5325-17-049-7954	0	H0001	0279336	TULE, RUBBER	3 2	
18		B	2590-17-103-2637	6	H0001	0556468	DRAADSAMENSTEL, ELE	1 2	
19		B	2590-17-103-2636	5	H0001	0556466	DRAADSAMENSTEL, ELE	1 2	
21		B	0000-KL-041-0183	4	H0001	0643242	ELEKTRISCHE LEIDING	1 2	
24		B	2590-17-103-4428	4	H0001	0556470	DRAADSAMENSTEL, ELE	1 2	
27		B	6150-17-103-2438	5	H0001	0394660	KABELSAMENSTEL, VOED	1 2	
28		B	2590-17-103-2437	4	H0001	0386988	KABELSAMENSTEL, VOED	1 2	
29		B	5940-17-054-7708	1	H0001	0614801	AANSLUITING, SCHOEN	2 2	
					D9661	SKG-10G			
30		B	5940-17-054-7707	0	H0001	0614800	AANSLUITING, SCHOEN	2 2	
					D9661	SKG+12G			

PN 002083

BATTERIJKABELS

MOSNR 0603-0002 BLAD: 1

**YCHIE.ME**

**YCHIE.ME**

PROJECTNUMMER: 002083  
MOSNUMMER : 0604-0001

ELEC. CENTRAALKAST

DATUM 871102  
BLAD 1 VAN 1 BLADEN

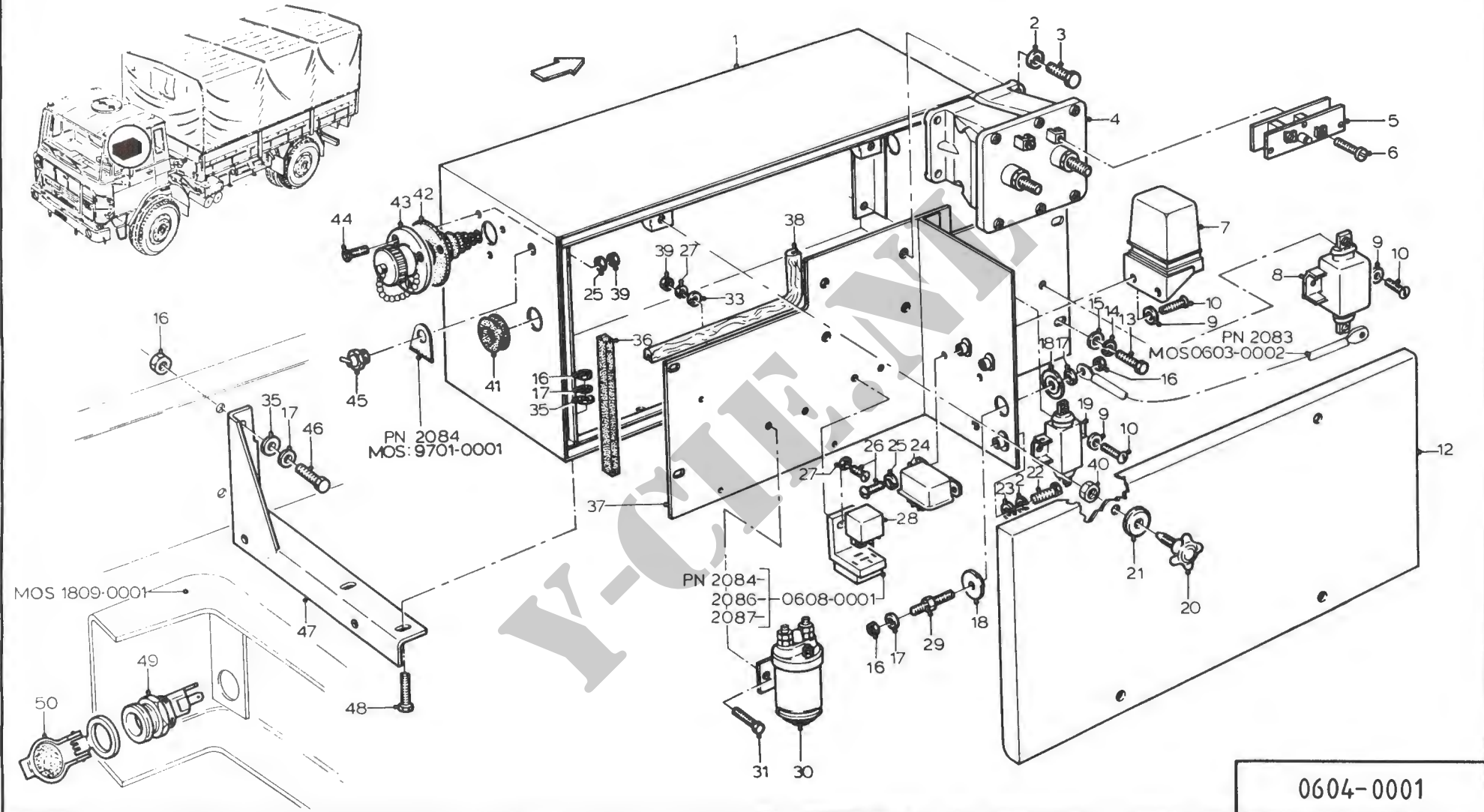

PN 002083

MOSNR 0604-0001

ELEC.CENTRAALKAST

DATUM: 890905 BLAD: 1

FIGNR	N MC	B	NSN	C	FCN	REFERENTIENUMMER (= FAN)	ARTIKELOMSCHRIJVING TOELICHTING	AANT ECH	OPMERKINGEN
2		B	5310-12-124-0892	3	H0001	0251939	ONDERLEGRING, BORG-	6 2	
					D8286	DIN6798-A8, 4			
3		B	5305-12-143-7855	0	H0001	0251622	SCHROEF, ZESKANTE KO	4 2	
					D8286	DIN933-M8X22-8.8-A2P			
4		B	5945-12-143-0199	0	H0001	0523803	RELAIS, ELEKTROMAGNE	1 2	
					D8015	0333301010			
5		B	5961-12-150-7613	7	H0001	0103183	HALFGELEIDERSAMENST	1 2	
					D8015	2337320500			
6		B	5305-12-142-0091	1	H0001	0251351	SCHROEF, MACHINE	2 2	
					D8286	DIN84-AM5X30-5.8-A2P			
7		B	2920-12-310-5808	1	H0001	0294600	REGLER, SCHUTZ-, VE	1 2	**
					D8015	0192900007			
8		B	5915-12-307-5252	3	H0001	0365693	FILTER, RADIO-INTERF	1 2	
					D8015	0290003031			
9		B	5310-12-162-2129	2	H0001	0251927	ONDERLEGRING, BORG-	6 2	
					D8286	DIN128-A6-FST			
10		B	5305-12-166-3829	1	H0001	0318916	SCHROEF, MACHINE	6 2	
					D8286	DIN7985-M6X16-4.8-H-A2P			
13		B	5305-12-146-2633	6	H0001	0126718	SCHROEF, ZESKANTE KO	4 2	
					D8286	DIN933-M6X16-8.8-A2P			
14		B	5310-12-124-0890	1	H0001	0251938	ONDERLEGRING, BORG-	4 2	
					D8286	DIN6798-A6, 4			
15		B	5310-12-142-0644	4	D8286	DIN125-B6, 4-ST-A3P	ONDERLEGRING, VLAK	4 2	
16		B	5310-12-144-6214	0	H0001	0251275	MOER, ZESKANT	10 2	
					D8286	DIN934-M8-8-A2P			
17		B	5310-12-162-2131	4	H0001	0251928	ONDERLEGRING, BORG-	8 2	
					D8286	DIN128-A8			
18		B	5310-17-054-8726	7	H0001	0170856	ONDERLEGRING, BORST	2 2	
19		B	5915-12-307-5407	4	H0001	0365692	FILTER, RADIO-INTERF	1 2	
					D8015	0290003030			
20		B	5355-17-049-8349	0	H0001	0623103	KNOP	2 2	
21		B	5310-17-049-9411	5	H0001	0317629	ONDERLEGRING, VLAK	2 2	
22		B	5305-12-156-4863	2	H0001	0251621	SCHROEF, ZESKANTE KO	2 2	
					D8286	DIN933-M8X20-8.8-A2P			
23		B	5310-12-149-4353	2	H0001	0325421	ONDERLEGRING, VLAK	2 2	
					D8286	DIN125-A8, 4-ST-A3P			
24		B	5961-12-311-2690	8	H0001	0296310	HALFGELEIDERSAMENST	1 2	
					C1058	V2748			
25		B	5310-12-158-6218	6	H0001	0251937	ONDERLEGRING, BORG-	9 2	
					D8286	DIN6798-A5, 1			
26		B	5305-12-142-5547	1	H0001	0521828	SCHROEF, MACHINE	4 2	
					D8286	DIN7985-M5X12-4.8-H-A2P			

PN 002083

ELEC.CENTRAALKAST

MOSNR 0604-0001 BLAD: 1

PN 002083

MOSNR 0604-0001

ELEC.CENTRAALKAST

DATUM: 890905

BLAD: 2

FIGNR	N MC	B	NSN	C	FCN	REFERENTIENUMMER (= FAN)	ARTIKELOMSCHRIJVING TOELICHTING	AANT ECH	OPMERKINGEN
27		B	5310-12-189-1721	6	H0001	0251926	ONDERLEGRING, BORG-	4 2	
					D8286	DIN128-A5			
28		B	5945-12-178-5081	0	H0001	0515912	RELAIS, ELEKTROMAGNE	1 2	
					D8015	0332204206			
29		B	5307-17-054-8731	1	H0001	0661569	TAPEIND, BORST	1 2	
30		B	0000-KL-041-1731	1	H0001	0589588	RELAIS	1 2	
31		B	5305-12-141-9824	9	H0001	0251605	SCHROEF, ZESKANTE KO	2 2	
					D8286	DIN933-M5X12-8.8-A2P			
32		B	5305-12-153-5721	0	H0001	0126716	SCHROEF, ZESKANTE KO	4 2	
					D8286	DIN933-M5X16-8.8-A2P			
33		B	5310-12-156-4912	7	H0001	0542018	ONDERLEGRING, VLAK	6 2	
					D8286	DIN125-B5, 3-ST-A3P			
34		B	5340-17-055-0063	2	H0001	0622205	BEVESTIGINGSPLAAT	1 2	
35		B	5310-12-142-0481	6	D8286	DIN125-B10, 5-ST-A3P	ONDERLEGRING, VLAK	6 2	
36		B	5330-17-103-2439	6	H0001	0559043	AFDICHTING, RUBBER 1 METER	1 2	
38		B	9390-12-175-3056	7	H0001	0588746	NONMETALLIC CHANNEL 0,51 METER	NB 2	MR
					C0310	17300			
39		B	5310-12-156-4990	8	H0001	0251273	MOER, ZESKANT	5 2	
					D8286	DIN934-M5-8-A2P			
40		B	5310-12-144-6214	0	D8286	DIN934-M8-8-A2P	MOER, ZESKANT	2 2	
41		B	5325-17-100-0637	5	H0001	0325239	TULE, RUBBER	1 2	
42		B	9320-17-051-1362	0	H0001	0644226	BALG, BESCHERM-	1 2	
43		B	5935-12-146-6901	6	H0001	0338909	CONNECTOR, DOOS, ELEK	1 2	
44		B	5305-12-171-2027	8	H0001	0319085	SCHROEF, MACHINE	3 2	
					D8286	DIN965-M5X16-5.8-H-A2P			
45		B	5930-14-400-5218	5	H0001	0105199	SCHAKELAAR, TUIMEL-	1 2	
					F0894	2702B5-3			
46		B	5305-12-156-4865	4	H0001	0251623	SCHROEF, ZESKANTE KO	2 2	
					D8286	DIN933-M8X25-8.8-A2P			
48		B	5305-12-155-6878	3	H0001	0126720	SCHROEF, ZESKANTE KO	4 2	
					D8286	DIN933-M8X16-8.8-A2P			

PN 002083

ELEC.CENTRAALKAST

MOSNR 0604-0001 BLAD: 2

38

-LAATSTE BLAD-

**YCHIE.ME**

PROJECTNUMMER: 002083  
MOSNUMMER : 0604-0003

# CONTACTDOZEN OP LAADBAK

DATUM 871102  
BLAD 1 VAN 1 BLADEN

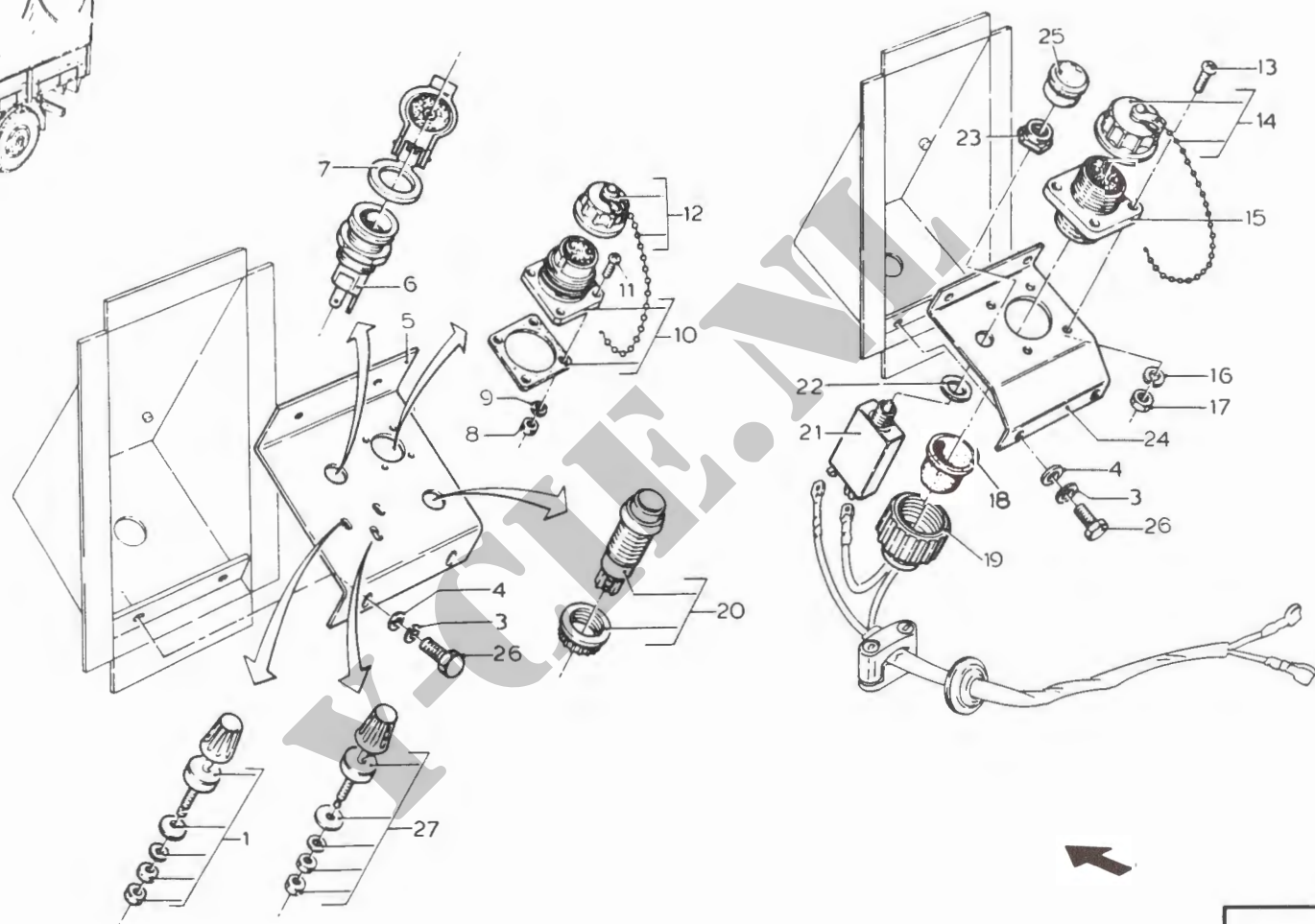
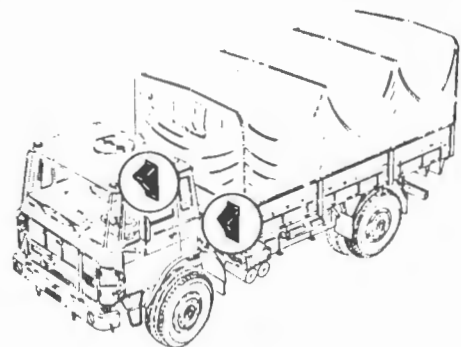

0604-0003

PN 002083

MOSNR 0604-0003

CONTACTDOZEN OP LAADBAK

DATUM: 890905 BLAD: 1

FIGNR	N MC	B	NSN	C	FCN	REFERENTIENUMMER (= FAN)	ARTIKELOMSCHRIJVING TOELICHTING	AANT ECH	OPMERKINGEN
1		B	5940-99-056-0055	1	U0154	L1301	INSTRUMENTENKLEM, EL	2 2	
3		B	5310-12-124-0890	1	H0001	0251938	ONDERLEGRING, BORG-	4 2	
					D8286	DIN6798-A6, 4			
4		B	5310-12-142-0644	4	D8286	DIN125-B6, 4-ST-A3P	ONDERLEGRING, VLAK	4 2	
6		B	5935-12-169-1823	0	H0001	0621367	CONNECTOR, DOOS, ELEK	2 2	
					D8015	0352222006			
7		B	5935-12-178-2265	0	H0001	0621368	DEKSEL	2 2	
					D8143	1350500012			
8		B	5310-12-144-6201	8	H0001	0251271	MOER, ZESKANT	4 2	
					D8286	DIN934-M3-8-A2P			
9		B	5310-12-131-5576	8	H0001	0251935	ONDERLEGRING, BORG-	4 2	
					D8286	DIN6798-A3, 2			
10		B			H0001	0815550	STEKERDOOS	1 2	
					F6192	SOC 2 OEF 23 C			
11		B	5305-12-142-0050	4	H0001	0251331	SCHROEF, MACHINE	4 2	
					D8286	DIN84-M3X10-5.8-A2P			
12		B	5935-14-202-8997	0	H0001	0815551	AFDEKKING, ELEKTRISC	1 2	
					F6192	SOC BEF 2			
13		B	5305-12-142-0074	6	H0001	0251340	SCHROEF, MACHINE	4 2	
					D8286	DIN84-M4X12-5.8-A2P			
14		B	5935-01-176-1708	2	96906	MS25043-22DA	KAP, ELEKTRISCH	1 2	
16		B	5310-12-124-0888	0	H0001	0251936	ONDERLEGRING, BORG-	4 2	
					D8286	DIN6798-A4, 3			
17		B	5310-12-144-6203	0	H0001	0251272	MOER, ZESKANT	4 2	
					D8286	DIN934-M4-8-A2P			
18		B	5325-00-338-1274	6	H0001	0744046	GROMMET, NONMETALLIC	1 2	
19		B	5935-00-333-9414	1	H0001	0744045	PAKKINGMOER, ELEKTRI	1 2	
20		B	5930-12-133-5959	8	H0001	0802907	SCHAKELAAR, DRUK-	1 2	
21		B	5925-12-162-8517	0	H0001	0622171	STROOMKRINGVERBREKE	1 2	
					D8885	412-K5/1-FN2-25A			
22		B	5310-12-189-1721	6	H0001	0251926	ONDERLEGRING, BORG-	1 2	
					D8286	DIN128-A5			
23		B	5310-12-156-4990	8	H0001	0251273	MOER, ZESKANT	1 2	
					D8286	DIN934-M5-8-A2P			
25		B	5999-12-166-7877	1	H0001	0821983	KAPPE	1 2	
					D8885	N. 480. 12/R1			
26		B	5305-12-156-4860	0	H0001	0251610	SCHROEF, ZESKANTE KO	2 2	
					D8286	DIN933-M6X12-8.8-A2P			
27		B	5940-99-119-1544	2	H0001	0821985	INSTRUMENTENKLEM, EL	1 2	
					U0154	L1301RED			

PN 002083

CONTACTDOZEN OP LAADBAK

MOSNR 0604-0003 BLAD: 1

**YCHIE.ME**

**YCHIE.ME**

PROJECTNUMMER: 002083  
MOSNUMMER : 0604-0004

# EL.ZEKERINGKAST IN CABINE

DATUM 871102  
BLAD 1 VAN 1 BLADEN

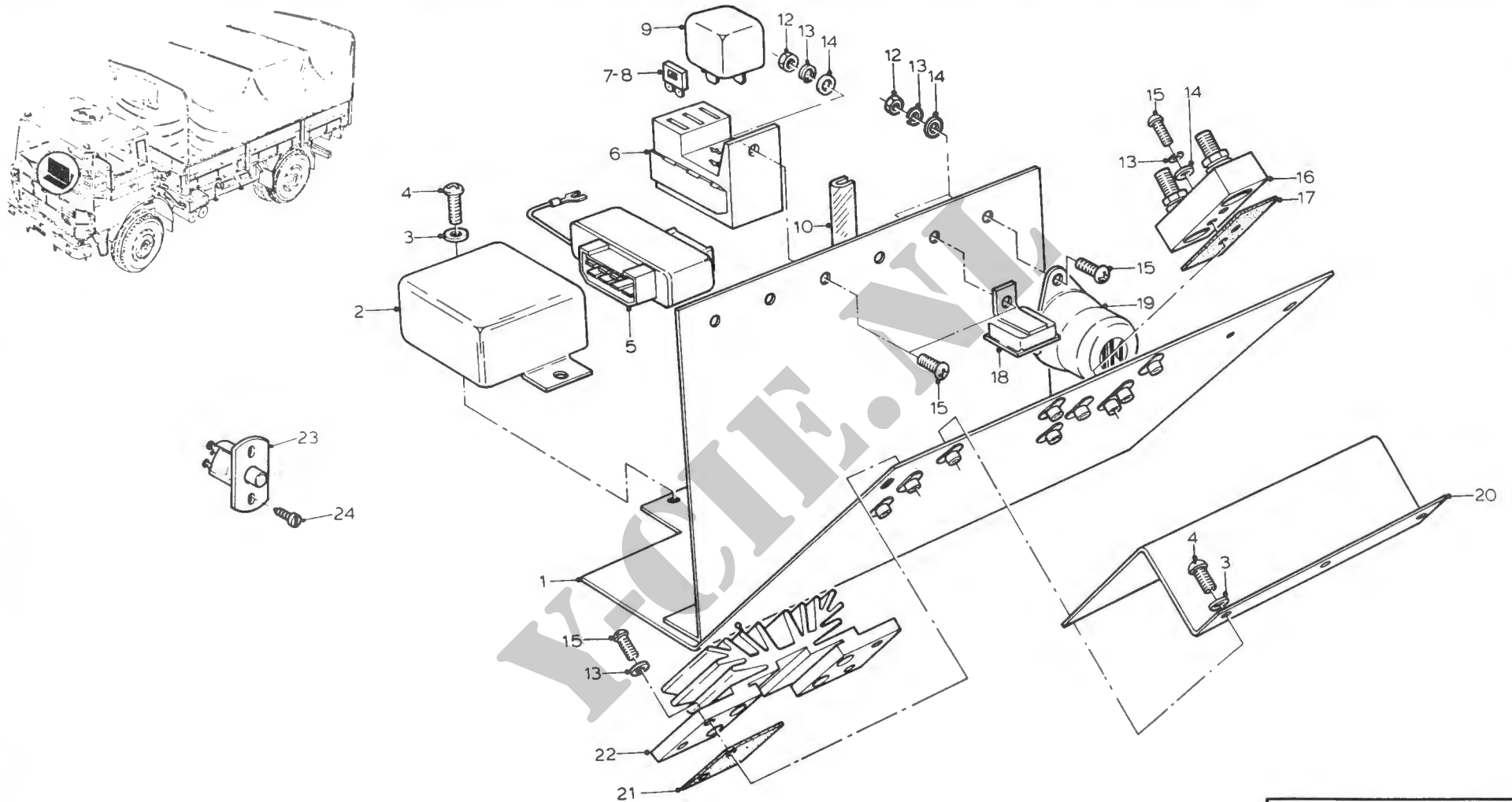

0604-0004

PN 002083

MOSNR 0604-0004

EL.ZEKERINGKAST IN CABINE

DATUM: 890905 BLAD: 1

FIGNR	N MC	B	NSN	C	FCN	REFERENTIENUMMER (= FAN)	ARTIKELOMSCHRIJVING TOELICHTING	AANT ECH	OPMERKINGEN
2		B	5945-12-151-4354	5	H0001	0621970	KNIPPERLICHTAUTOMAA	2 2	
					D8095	4DN001863-11			
3		B	5310-12-162-2129	2	H0001	0251927	ONDERLEGRING, BORG-	5 2	
					D8286	DIN128-A6-FST			
4		B	5305-12-142-5565	8	H0001	0318915	SCHROEF, MACHINE	5 2	
					D8286	DIN7985-M6X10-4.8-H-A2P			
5		B	5915-12-151-4353	4	H0001	0621971	FILTER, RADIO-INTERF	1 2	
					D8095	8JA002440-00			
7		B	5920-17-911-0453	5	H0001	0657560	SMELTVEILIGHEID, ING 7,5 AMP	22 2	
					D8143	34902002			
8		B	5920-17-911-0452	4	H0001	0657561	SMELTVEILIGHEID, ING 15 AMP	6 2	
					D8143	34902004			
9		B	5945-12-178-5081	0	H0001	0515912	RELAIS, ELEKTROMAGNE	9 2	
					D8015	0332204206			
10		B	9390-12-175-3056	7	H0001	0588746	NONMETALLIC CHANNEL	NB 2	MR
					C0310	17300			
12		B	5310-12-156-4990	8	H0001	0251273	MOFR, ZESKANT	4 2	
					D8286	DIN934-M5-8-A2P			
13		B	5310-12-189-1721	6	H0001	0251926	ONDERLEGRING, BORG-	10 2	
					D8286	DIN128-A5			
14		B	5310-12-156-4912	7	H0001	0542018	ONDERLEGRING, VLAK	4 2	
					D8286	DIN125-B5, 3-ST-A3P			
15		B	5305-12-136-4123	1	H0001	0521829	SCHROEF, MACHINE	10 2	
					D8286	DIN7985-M5X15-4.8-H-A2P			
16		B	2590-17-054-7981	0	H0001	0623707	KONTAKTBLOK	1 2	
17		B	2510-17-054-7485	9	H0001	0623709	ISOLATORPLAAT	1 2	
18		B	5961-12-172-1272	2	H0001	0629678	HALFGELEIDER, DIODE	1 2	
19		B	6350-99-718-4721	5	H0001	0614915	ZOEMER	1 2	
					K7354	FT550H224V			
23		B	5930-12-171-8257	1	H0001	0217642	SCHAKELAAR, DRUK-	2 2	
24		B	5305-12-142-5728	6	D8286	DIN7981-ST4, 2X9, 5-C-H-A3P	SCHROEFF, ZELFSCHROEF	4 2	

PN 002083

EL.ZEKERINGKAST IN CABINE

MOSNR 0604-0004 BLAD: 1

**KCH.ME**

**YCHIE.ME**

PROJECTNUMMER: 002083

MOSNUMMER : 0605-0002

# SNELHEIDSMETER TOERENTELLER

DATUM 871102

BLAD 1 VAN 1 BLADEN

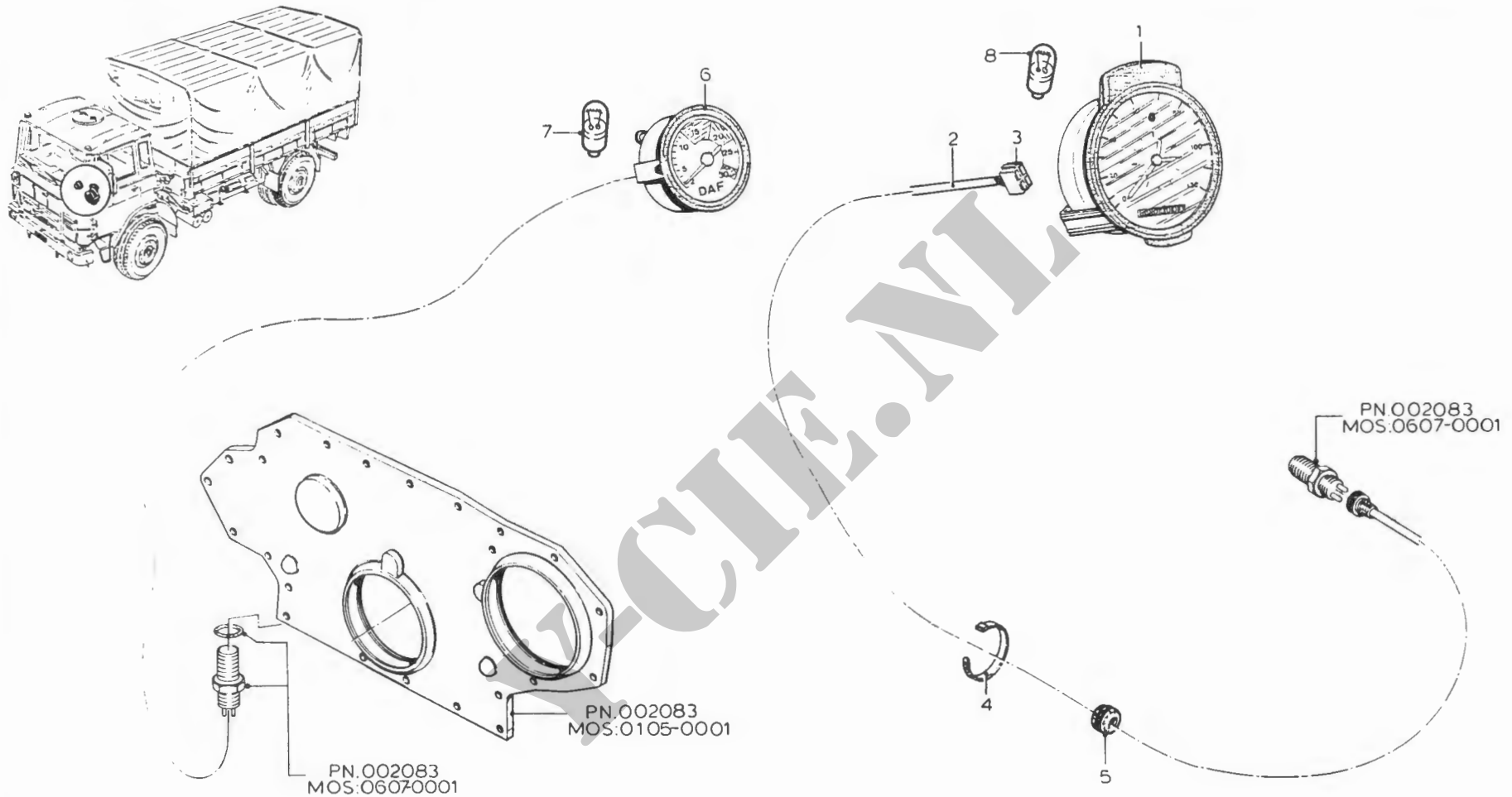

0605-0002

PN 002083

MOSNR 0605-0002

SNELHEIDSMETER TOERENTELLER

DATUM: 890905

BLAD: 1

FIGNR	N	MC	B	NSN	C	FCN	REFERENTIENUMMER (= FAN)	ARTIKELOMSCHRIJVING	TOELICHTING	AANT	ECH	OPMERKINGEN
1			B	6680-12-310-4365	0	H0001	0659384	SNELHEIDSMETER EN T		1	2	R
3			B	5935-12-157-7159	0	H0001	0580010 D8512 180900	HULS, ELEKTRISCHE CO		1	2	
4			B	5975-01-302-8207	5			RIEM, BIND-, ELEKTRIS		1	2	
5			B	5325-17-103-2440	7	H0001	0666745	TULF		1	2	
6			B	6680-17-911-0470	0	H0001	0282471 D4276 333.430/011/010	AANWYZER, ELEKTRISCH		1	2	R
7			B	6240-12-148-0432	7	H0001	0627256	LAMP, GLOEI-		1	2	
8			B	0000-KL-036-9805	7	H0001	0667409 D8286 LD24-1DIN49846 D8039 HW004067	FIT, GLOEILAMP		1	2	

PN 002083

SNELHEIDSMETER TOERENTELLER

MOSNR 0605-0002 BLAD: 1

41

-LAATSTE BLAD-

**Y-CHE.ME**

**Y-CHE.ME**

PROJECTNUMMER: 002083

MOSNUMMER : 0606-0001

VERLICHTING

DATUM 871102

BLAD 1 VAN 1 BLADEN

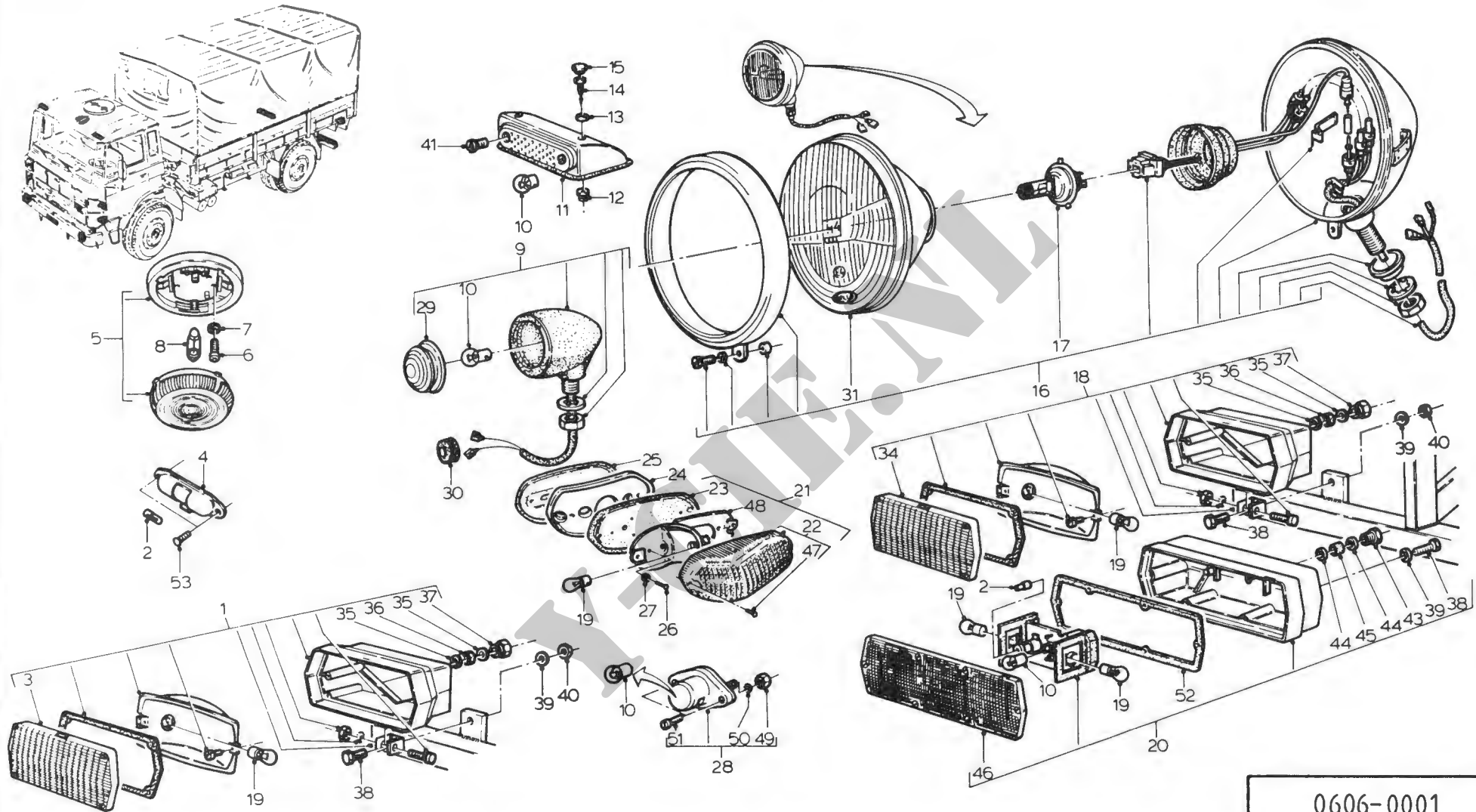

0606-0001

PN 002083

MOSNR 0606-0001

VERLICHTING

DATUM: 890905

BLAD: 1

FIGNR	N MC	B	NSN	C	FCN	REFERENTIENUMMER (= FAN)	ARTIKELOMSCHRIJVING TOELICHTING	AANT ECH	OPMERKINGEN
1		B	6220-12-176-0703	9	H0001	0664644	LICHTARMATUUR, ACHE	1 2	
					D8095	2ZR 002 481-02			
2		B	6240-12-120-7952	8	H0001	0356098	LAMP, GLOEI-	5 2	
					H0002	13913			
3		B	6220-12-178-3507	0	H0001	0696352	LENS, LICHTARMATUUR	1 2	
4		B	6210-12-121-7333	6	H0001	0179387	LICHTARMATUUR, PANEE	2 2	0606/0001/00001
5		B	6220-12-176-0704	0	H0001	0641800	LICHTARMATUUR, KOEPE	1 2	
6		B	5305-12-142-5531	7	H0001	0318904	SCHROEF, MACHINE	2 2	
					D8286	DIN7985-M4X12-4.8-H-A2P			
7		B	5310-12-198-6973	9	H0001	0251925	ONDERLEGRING, BORG-	2 2	
					D8286	DIN128-A4			
8		B	6240-12-124-1231	1	C3296	13850	LAMP, GLOEI-	1 2	
					H0001	0119028			
9		B	6220-99-719-3612	8	H0001	0638888	ZIJLICHT	2 2	
					K1078	12-01-01			
10		B	6240-12-173-4824	2	D8286	DIN72601-R19/5-24V5W	LAMP, GLOEI-	6 2	
11		B	6220-12-162-0717	9			LICHTARMATUUR, MARKE	2 2	0606/0001/00009
12		B					MOER	8 2	
13		B	5310-12-177-2607	0	H0001	0227326	ONDERLEGRING, VLAK	4 2	
					C0136	TN300M5VPV0			
14		B	5305-12-176-6079	6	H0001	0522067	SCHROEF, ZELFSCHROEF	4 2	
					D8286	DIN7981-ST4, 2X32-C-H-A3P			
15		B	5340-12-175-0998	6	H0001	0590578	STOP, BFSCHERM-, STOF	4 2	
					D8794	11919			
16		B	6220-12-183-1411	9	H0001	0636809	KOPLICHTARMATUUR, VO	2 2	
17		B	6240-12-180-0912	2	H0001	0617013	LAMP, GLOEI-	2 2	
18		B	6220-12-152-8600	6	H0001	0621972	LICHTARMATUUR, MIST	1 2	0606/0001/00016
19		B	6240-12-173-4827	5	D8286	DIN72601-P25-1-24V21W	LAMP, GLOEI-	7 2	
20		B	6220-12-151-4411	7	H0001	0509900	STOP-EN-ACHTERLICHT	2 2	
21		B	6220-12-197-2897	2	H0001	0330621	RICHTINGAANWYZERARM	2 2	
					D8130	300906			
22		B	6220-12-302-6985	4	H0001	0229525	LENS, LICHTARMATUUR	2 2	
					D8130	395930			
24		B	6250-17-049-9906	5	H0001	0228669	MONTAGEPLAAT, LAMPHO	2 2	0606/0001/00021

PN 002083

VERLICHTING

MOSNR 0606-0001 BLAD:

1

PN 002083

MOSNR 0606-0001

VERLICHTING

DATUM: 890905 BLAD: 2

FIGNR	N MC	B	NSN	C	FCN	REFERENTIENUMMER (= FAN)	ARTIKELOMSCHRIJVING TOELICHTING	AANT ECH	OPMERKINGEN
25		B	5330-17-050-3022	8	H0001	0228670	GASKET	2 2	
26		B	5305-12-142-5547	1	H0001	0521828	SCHROEF, MACHINE	8 2	
					D8286	DIN7985-M5X12-4.8-H-A2P			
27		B	5310-12-162-2129	2	H0001	0251927	ONDERLEGRING, BORG-	8 2	
					D8286	DIN128-A6-FST			
28		B	6220-12-159-6554	2	H0001	0509902	LIGHT, UTILITY, VEHIC	1 2	
30		B	5325-17-004-7225	7	H0001	0119084	TULE, RUBBER	2 2	
31		B	6220-12-183-7919	5	H0001	0694098	LAMPÉENHEID, VOERTUI	1 2	
									0606/0001/00016
34		B	6220-12-164-7718	5	H0001	0694095	LENS, LICHTARMATUUR	1 2	
35		B	5310-12-164-1827	0	H0001	0694103	PAKINGRING	4 2	
					D8095	9NU104487-00			
36		B	5330-12-151-4413	9	H0001	0694096	GASKET	2 2	
					D8095	9GD104486-00			
38		B	5305-12-155-6878	3	H0001	0126720	SCHROEF, ZESKANTE KO	2 2	
					D8286	DIN933-M8X16-8.8-A2P			
39		B	5310-12-162-2131	4	H0001	0251928	ONDERLEGRING, BORG-	3 2	
					D8286	DIN128-A8			
40		B	5310-12-144-6214	0	H0001	0251275	MOER, ZESKANT	1 2	
					D8286	DIN934-M8-8-A2P			
41		B	5305-00-011-6338	2	H0001	0522095	SCHROEF, ZELFSCHROEF	2 2	
					D8286	DIN7983-4, 2X19X8, 1-ST			DIT NSN IS VERVALLEN BIJ BESTELLING
			5305-12-311-4002						
44		B	5310-12-164-1827	0	H0001	0694103	PAKINGRING	2 2	
					D8095	9NU104487-00			
45		B	5330-12-151-4413	9	H0001	0694096	GASKET	1 2	
					D8095	9GD104486-00			
46		B	6220-12-151-4412	8	H0001	0694097	LENS, LICHTARMATUUR	1 2	
									0606/0001/00020
47		B	5305-17-906-9410	3	H0001	0229524	SCHROEF	2 2	
					D8130	905879			DIT NSN IS VERVALLEN 0606/0001/00022 BIJ BESTELLING
			5305-12-142-5529						
49		B	5310-12-156-4991	9	H0001	0251274	MOER, ZESKANT	2 2	
					D8286	DIN934-M6-8-A2P			
50		B	5310-12-124-0890	1	H0001	0251938	ONDERLEGRING, BORG-	2 2	
					D8286	DIN6798-A6, 4			0606/0001/00028

PN 002083

VERLICHTING

MOSNR 0606-0001 BLAD: 2

PN 002083

MOSNR 0606-0001

VERLICHTING

DATUM: 890905

BLAD: 3

FIGNR	N	MC	B	NSN	C	FCN	REFERENTIENUMMER (= FAN)	ARTIKELOMSCHRIJVING TOELICHTING	AANT ECH	OPMERKINGEN
51			B	5305-12-142-0076	8	H0001 D8286	0251342 DIN84-M4X20-5.8-A2P	SCHROEF, MACHINE	3 2	
52			B	5330-12-187-8112	4	H0001 D8095	0698419 9GD104543-00	GASKET	2 2	0606/0001/00028
53			B	0000-KL-041-0209	8	H0001 D8286	0318988 DIN966-M4X10X7,5X2,2	SCHROEF	4 2	0606/0001/00020

Y-CHE.ML

PN 002083

VERLICHTING

MOSNR 0606-0001

BLAD: 3

**YCHIE.ME**

**Y-CHE.ME**

PROJECTNUMMER: 002083  
MOSNUMMER : 0606-0002

VERLICHTING VERDUISTERD

DATUM 871102  
BLAD 1 VAN 1 BLADEN

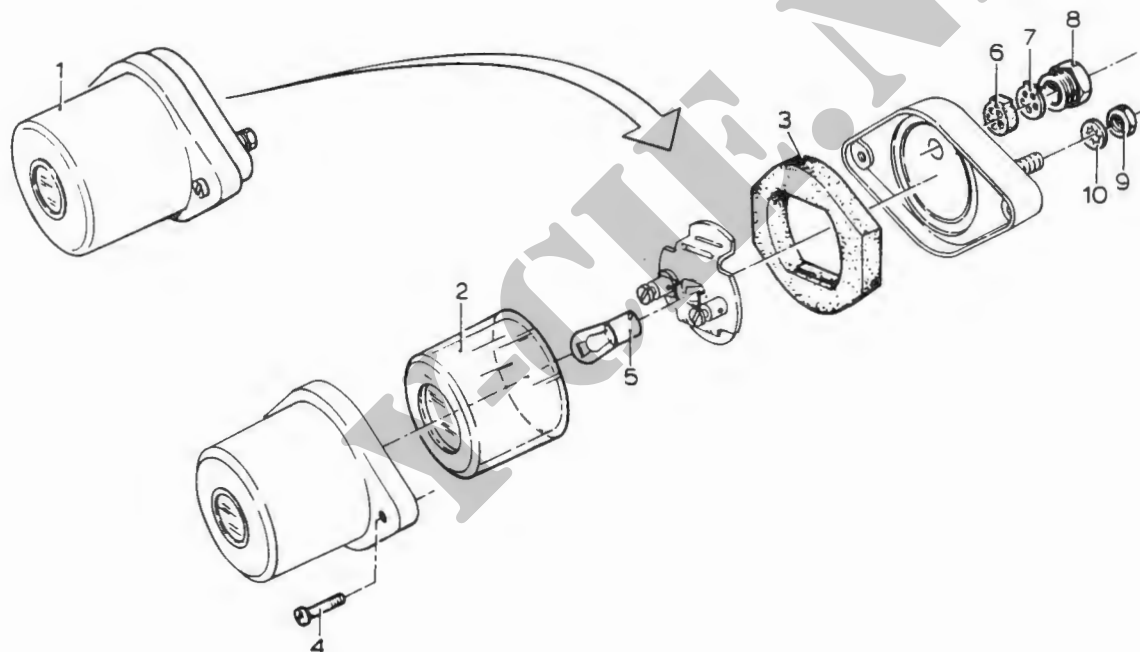
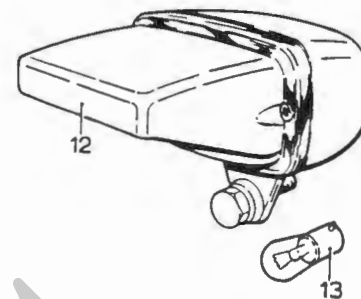
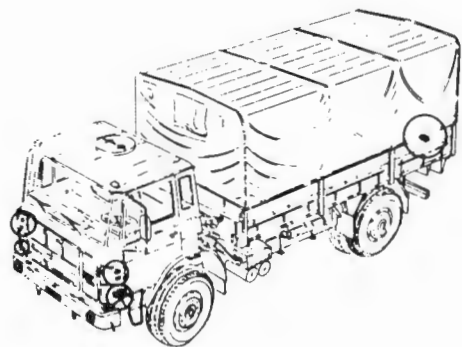

0606-0002

PN 002083

MOSNR 0606-0002

VERLICHTING VERDUISTERIJ

DATUM: 890905 BLAD: 1

FIGNR	N	MC	B	NSN	C	FCN	REFERENTIENUMMER (= FAN)	ARTIKELOMSCHRIJVING TOELICHTING	AANT	ECH	OPMERKINGEN
1			B	6220-12-151-4414	0	H0001	0509901	STOPLICHTARMATUUR, V	1	2	
						D8095	2DA 001 324-02				
2			B	6220-12-151-4415	0	H0001	0691099	LENS, LICHTARMATUUR	1	2	
						D8095	9EL 072 373-00				
4			B	5305-12-142-0076	8	H0001	0251342	SCHROEF, MACHINE	2	2	
						D8286	DIN84-M4X20-5.8-A2P				
5			B	6240-12-120-7952	8	H0001	0356098	LAMP, GLOEI-	1	2	
						D8286	DIN72601-H-24V2W				
6			B	5330-12-151-4413	9	H0001	0694096	GASKET	1	2	
						D8095	9GD104486-00				
7			B	5310-12-164-1827	0	H0001	0694103	PAKKINGRING	1	2	
						D8095	9NU104487-00				
9			B	5310-12-156-4991	9	H0001	0251274	MOER, ZESKANT	2	2	
						D8286	DIN934-M6-8-A2P				
10			B	5310-12-124-0890	1	H0001	0251938	ONDERLEGRING, BORG-	2	2	
						D8286	DIN6798-A6,4				
12			B	6220-12-121-7310	5	H0001	0179796	KOPLICHTARMATUUR, VO	2	2	
											DIT NSN IS VERVALLEN BIJ BESTELLING
13			B	6240-12-173-4827	5	D8286	DIN72601-P25-1-24V21W	LAMP, GLOEI-	2	2	

PN 002083

VERLICHTING VERDUISTERIJ

MOSNR 0606-0002 BLAD: 1

**KCH.ME**

**Y-CHE.ME**

PROJECTNUMMER: 002083  
MOSNUMMER : 0608-0002

EL.LEIDINGBOMEN LAADBAK

DATUM 871102  
BLAD 1 VAN 1 BLADEN

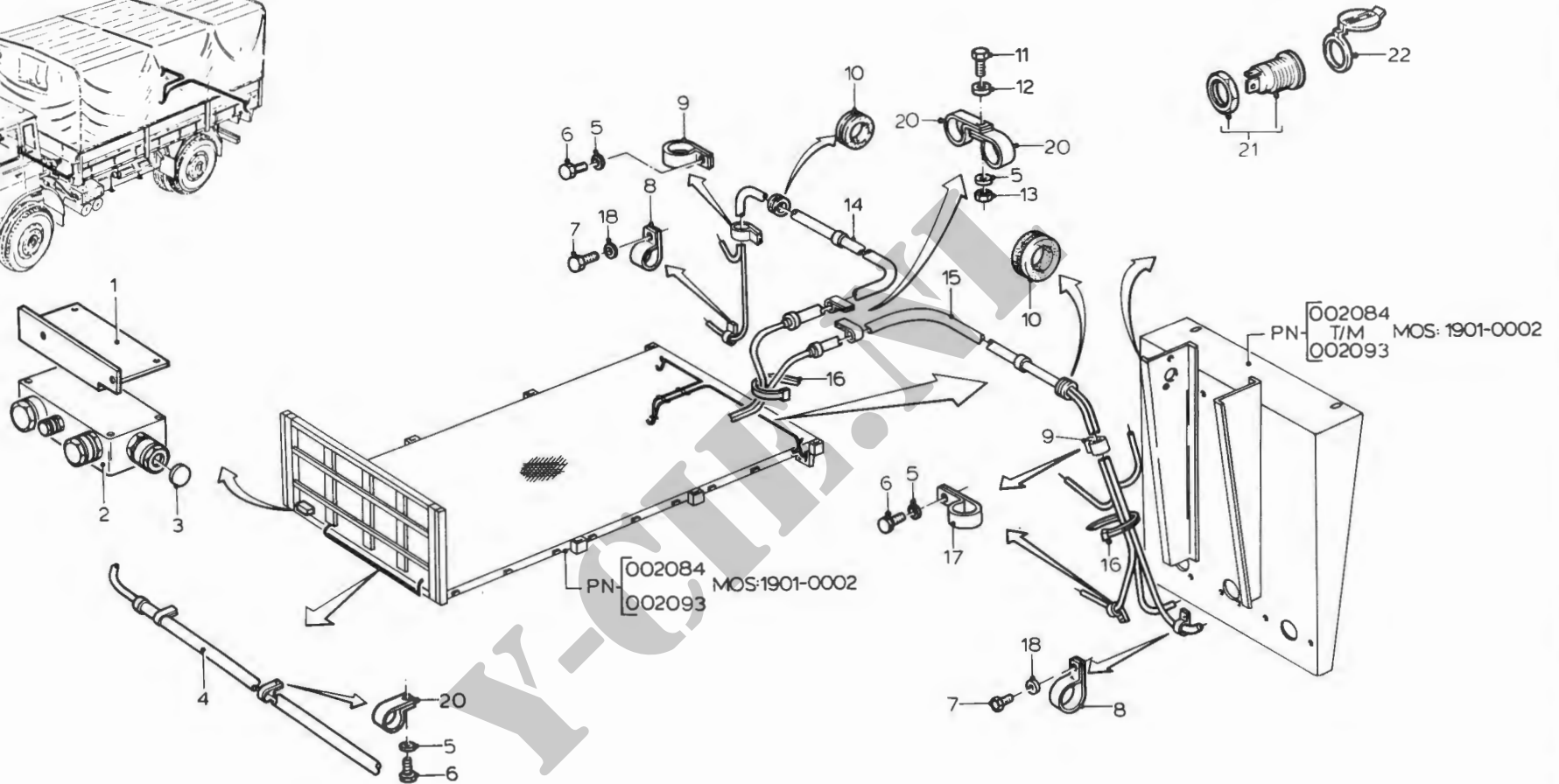
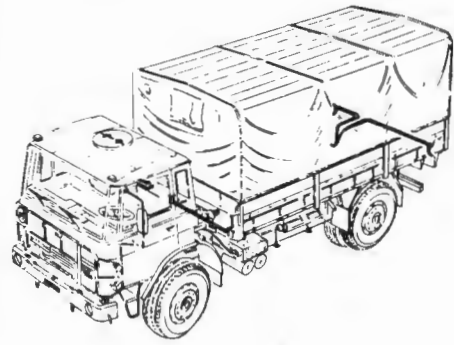

0608-0002

PN 002083

MOSNR 0608-0002

EL.LEIDINGBOMEN LAADBAK

DATUM: 890905

BLAD: 1

FIGNR	N	MC	B	NSN	C	FCN	REFERENTIENUMMER (= FAN)	ARTIKELOMSCHRIJVING	TOELICHTING	AANT	ECH	OPMERKINGEN
5			B	5310-12-162-2129	2	H0001	0251927	ONDERLEGRING, BORG-		4	2	
						D8286	DIN128-A6-FST					
6			B	5305-12-156-4862	1	H0001	0251612	SCHROEF, ZESKANTE KO		4	2	
						D8286	DIN933-M6X20-8.8-A2P					
7			B	5305-12-155-6878	3	H0001	0126720	SCHROEF, ZESKANTE KO		3	2	
						D8286	DIN933-M8X16-8.8-A2P					
8			B	5340-12-142-8514	9	H0001	0259589	KLEM, LUS		2	2	
						D8286	DIN3016-D1-10X20-W1-2					
9			B	5340-12-159-4283	8	H0001	0610734	KLEM, LUS		2	2	
						D8286	DIN3016-D1-15X20-W1-2					
11			B	5305-12-156-4861	0	H0001	0251614	SCHROEF, ZESKANTE KO		2	2	
						D8286	DIN933-M6X25-8.8-A2P					
12			B	5310-12-142-0644	4	D8286	DIN125-B6,4-SΓ-A3P	ONDERLEGRING, VLAK		2	2	
13			B	5310-12-156-4991	9	H0001	0251274	MOER, ZESKANT		2	2	
						D8286	DIN934-M6-8-A2P					
16			B	5340-17-909-7372	3	H0001	0503450	KLEMBAND		1	2	
						D8794	12463					
17			B	5340-12-143-0054	9	H0001	0241312	KLEM, LUS		1	2	
						D8286	DIN3016-D1-10X15-W1-2					
18			B	5310-12-162-2131	4	H0001	0251928	ONDERLEGRING, BORG-		2	2	
						D8286	DIN128-A8					
20			B	5340-17-017-8547	0	H0001	0343929	KLEM, LUS		4	2	

PN 002083

EL.LEIDINGBOMEN LAADBAK

MOSNR 0608-0002 BLAD:

1

**YCHIE.ME**

**Y-CHE.ME**

PROJECTNUMMER: 002083

MOSNUMMER : 0609-0001

STARTMOTOR

DATUM 871102

BLAD 1 VAN 1 BLADEN

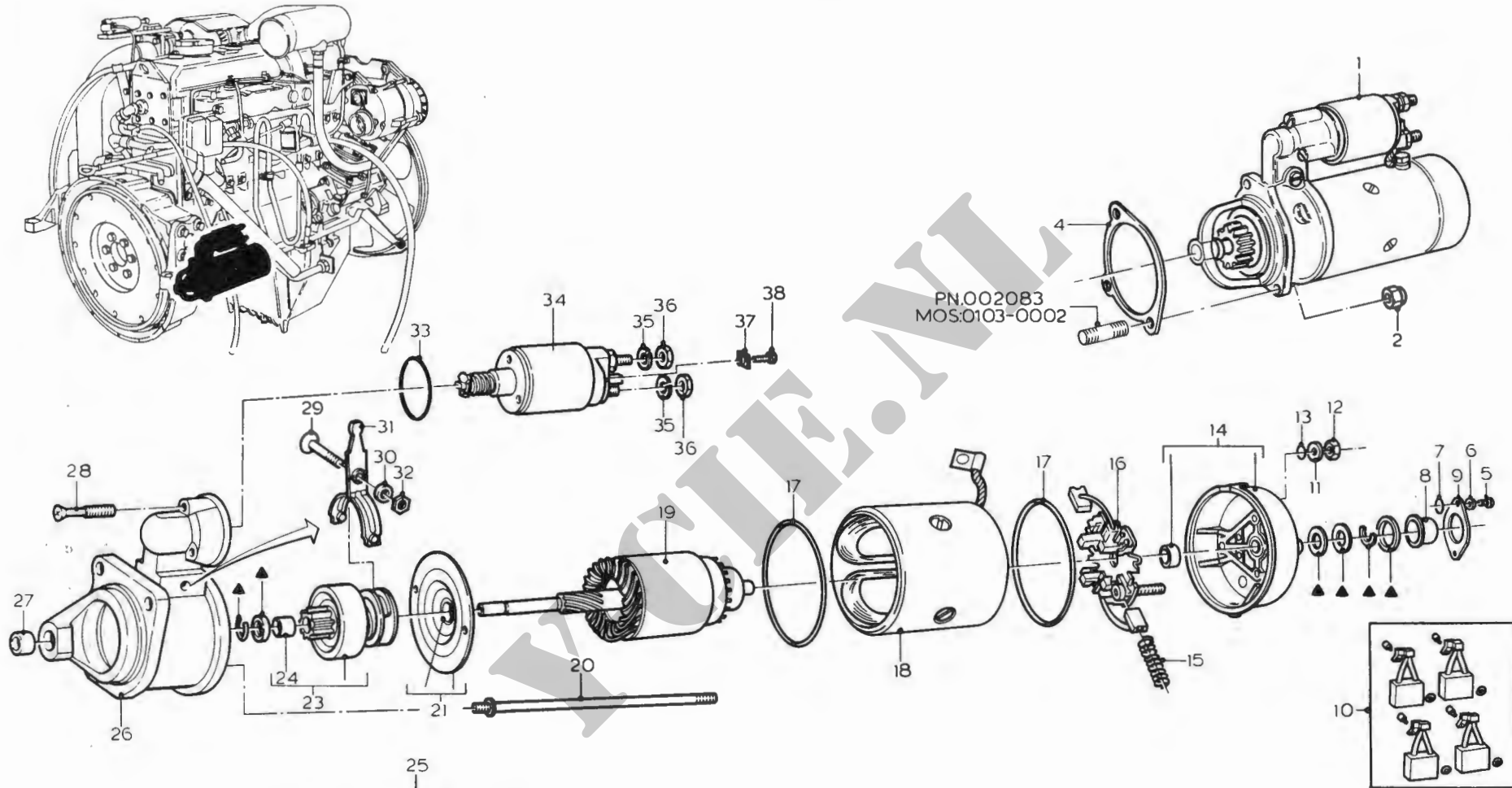

PN.002083  
MOS:0103-0002

REPARATIESET  
ONDERDELEN GEMERKT MET ▲

0609-0001

PN 002083

MOSNR 0609-0001

STARTMOTOR

DATUM: 890905

BLAD: 1

FIGNR	N	MC	B	NSN	C	FCN	REFERENTIE NUMMER (= FAN)	ARTIKELOMSCHRIJVING TOEIICHTING	AANT ECH	OPMERKINGEN
2			B	5310-12-191-9305	2	H0001	0523871	MOER, ZESKANT	3	2
						D8286	DIN934-M10X1,25-8-A2P			
4			B	5330-17-702-1896	7	H0001	0207750	GASKET	1	2
35			B	5310-12-125-0067	4	H0001	0186942	ONDERLEGRING, VEER-	2	2
						D8286	DIN137-B10			
36			B	5310-12-146-0644	8	H0001	0119210	MOER, ZESKANT	2	2
						D8286	DIN439-BM10-05-A2P			

Y-CHE.ME

PN 002083

STARTMOTOR

MOSNR 0609-0001 BLAD: 1

**Y-CHE.ME**

**YCHIE.ME**

PROJECTNUMMER: 002083

MOSNUMMER : 0610-0001

CLAXON

DATUM 871102

BLAD 1 VAN 1 BLADEN

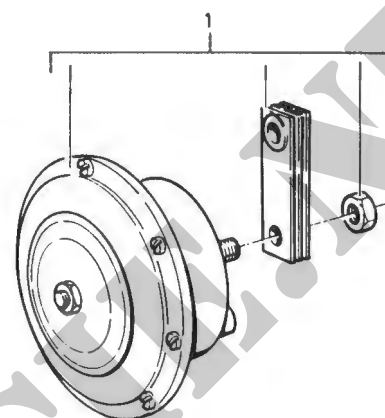
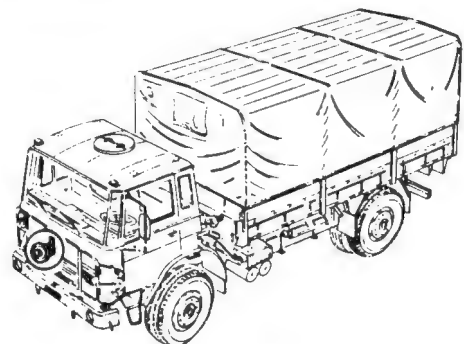

0610-0001

PN 002083

MOSNR 0610-0001

CLAXON

DATUM: 890905 BLAD: 1

FIGNR N MC B NSN C FCN REFERENTIENUMMER (= FAN)

ARTIKELOMSCHRIJVING TOEIICHTING AANT ECH OPMERKINGEN

1 B 0000-KL-044-1059 3 H0001 0740974  
D8015 0320226010

CLAXON 1 2

Y-CHE.ML

PN 002083

CLAXON

MOSNR 0610-0001 BLAD: 1

48

-LAATSTE BLAD-

**Y-CHE.ME**

**Y-CHE.ME**

PROJECTNUMMER: 002083  
MOSNUMMER : 0702-0004

### BEDIENINGSCILINDER

DATUM 871102  
BLAD 1 VAN 1 BLADEN

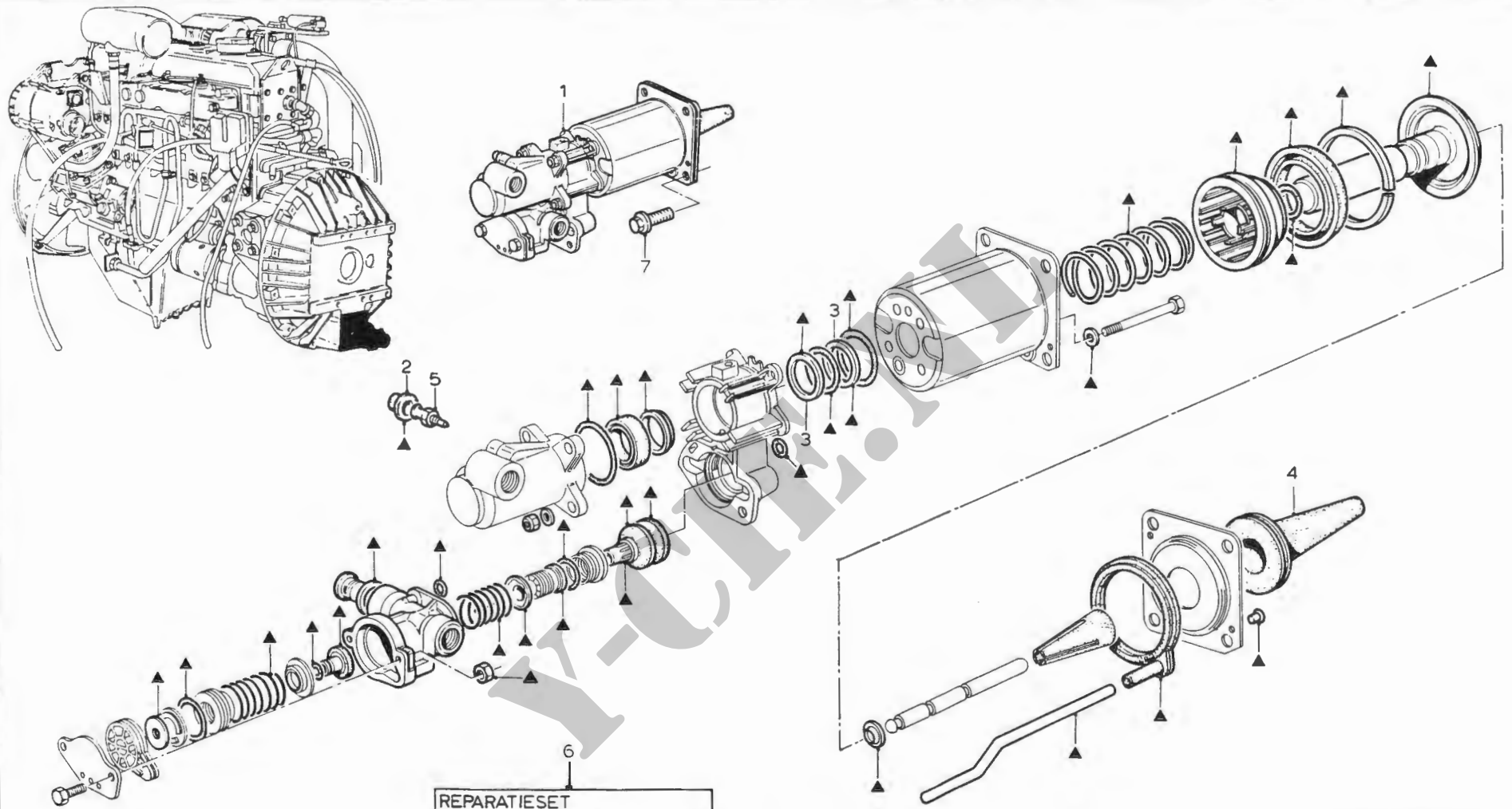

REPARATIESET  
ONDERDELEN GEMERKT MET ▲  
NIET GENUMMERDE DELEN  
NIET LOS LEVERBAAR

0702-0004

PN 002083

MOSNR 0702-0004

BEDIENINGSCILINDER

DATUM: 890905

BLAD: 1

FIGNR	N	MC	B	NSN	C	FCN	REFERENTIENUMMER (= FAN)	ARTIKELOMSCHRIJVING TOELICHTING	AANT	ECH	OPMERKINGEN
1			B	2590-12-316-9923	8	H0001	0390486	CILINDERSAMENSTEL, B	1	2	DR
2			B	2520-17-911-0447	0	H0001	0696072	DOP	1	2	
						D8096	8977540004				
5			B	2530-12-318-1376	0	H0001	0696071	VALVE, BLFEDER, HYDRA	1	2	**
						D8096	8913505204				
7			B	5306-12-317-5568	0	H0001	0268977	BOUT, MACHINE	4	2	
						D8286	DIN6921-M8X20-8.8-A2P				

YCHIE.ML

PN 002083

BEDIENINGSCILINDER

MOSNR 0702-0004 BLAD: 1

**KCH.ME**

**Y-CHE.ME**

PROJECTNUMMER: 002083  
MOSNUMMER : 0703-0002

# HUIS VERSNELLINGSBAK

DATUM 871102  
BLAD 1 VAN 1 BLADEN

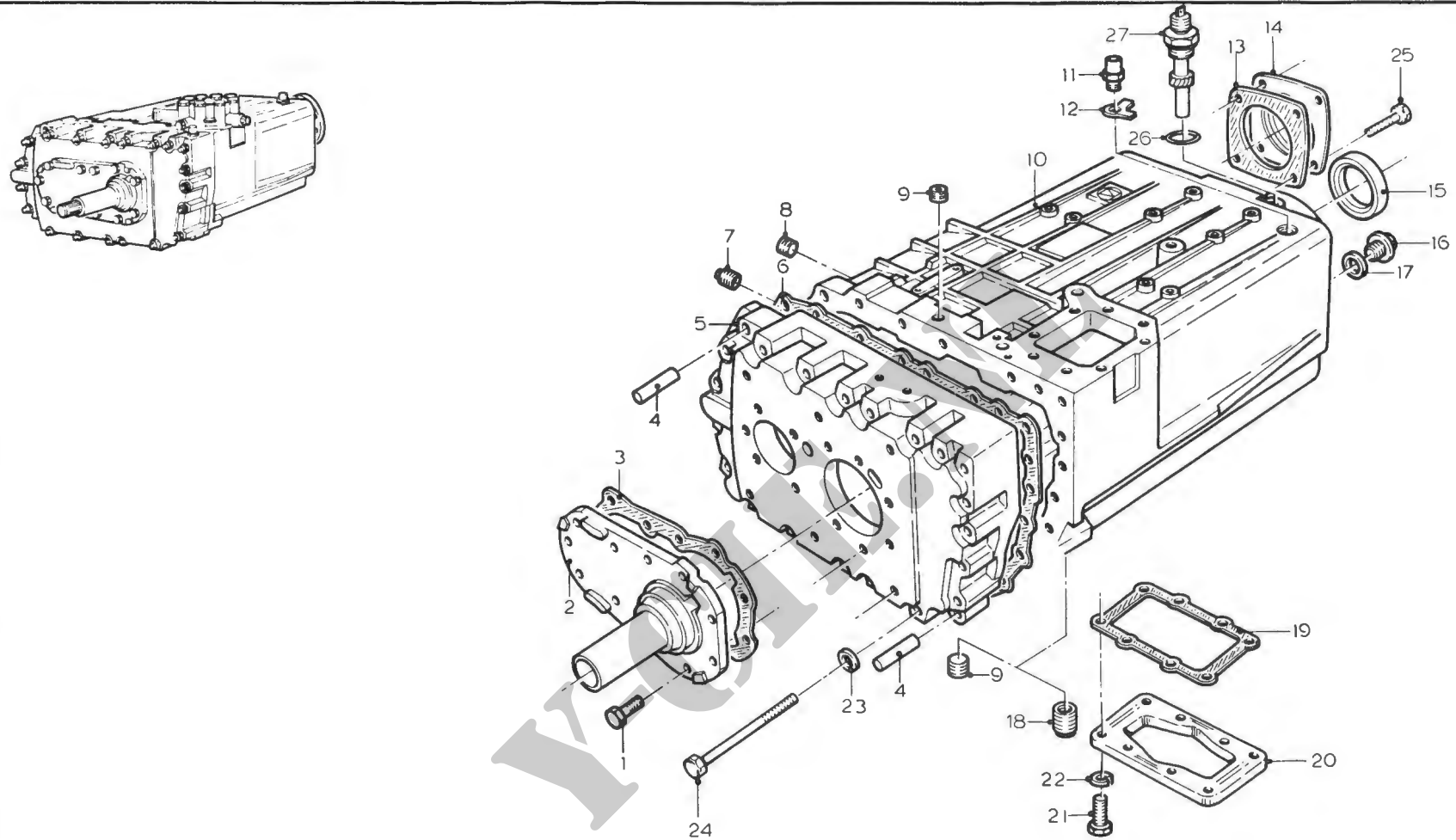

0703-0002

PN 002083

MOSNR 0703-0002

HUIS VERSNELLINGSBAK

DATUM: 890905

BLAD: 1

FIGNR	N	MC	B	NSN	C	FCN	REFERENTIENUMMER (= FAN)	ARTIKELOMSCHRIJVING TOELICHTING	AANT ECH	OPMERKINGEN
7			B	4730-12-148-1893	5	H0001	0326953	STOP,BUIS	1 2	
						D8124	0736303005			
8			B	4730-12-132-1347	4	H0001	0208996	STOP,BUIS	1 2	
9			B	4730-12-146-5439	7	H0001	0140878	STOP,BUIS	2 2	
						D8286	DIN906-M18X1,5-ST			
16			B	5365-12-142-9147	4	H0001	0692241	STOP, CILINDRISCHE	1 2	**
						D8124	0636304006			
17			B	5310-12-176-8083	8	H0001	0689418	ONDERLEGRING, VLAK	1 2	
						D8124	0730002064			

PN 002083

HUIS VERSNELLINGSBAK

MOSNR 0703-0002 BLAD: 1

50

-LAATSTE BLAD-

**Y-CHE.ME**

Y-CHE.ME

PROJECTNUMMER: 002083

MOSNUMMER : 0801-0002

HUIS TUSSENBAK

DATUM 871102

BLAD 1 VAN 1 BLADEN

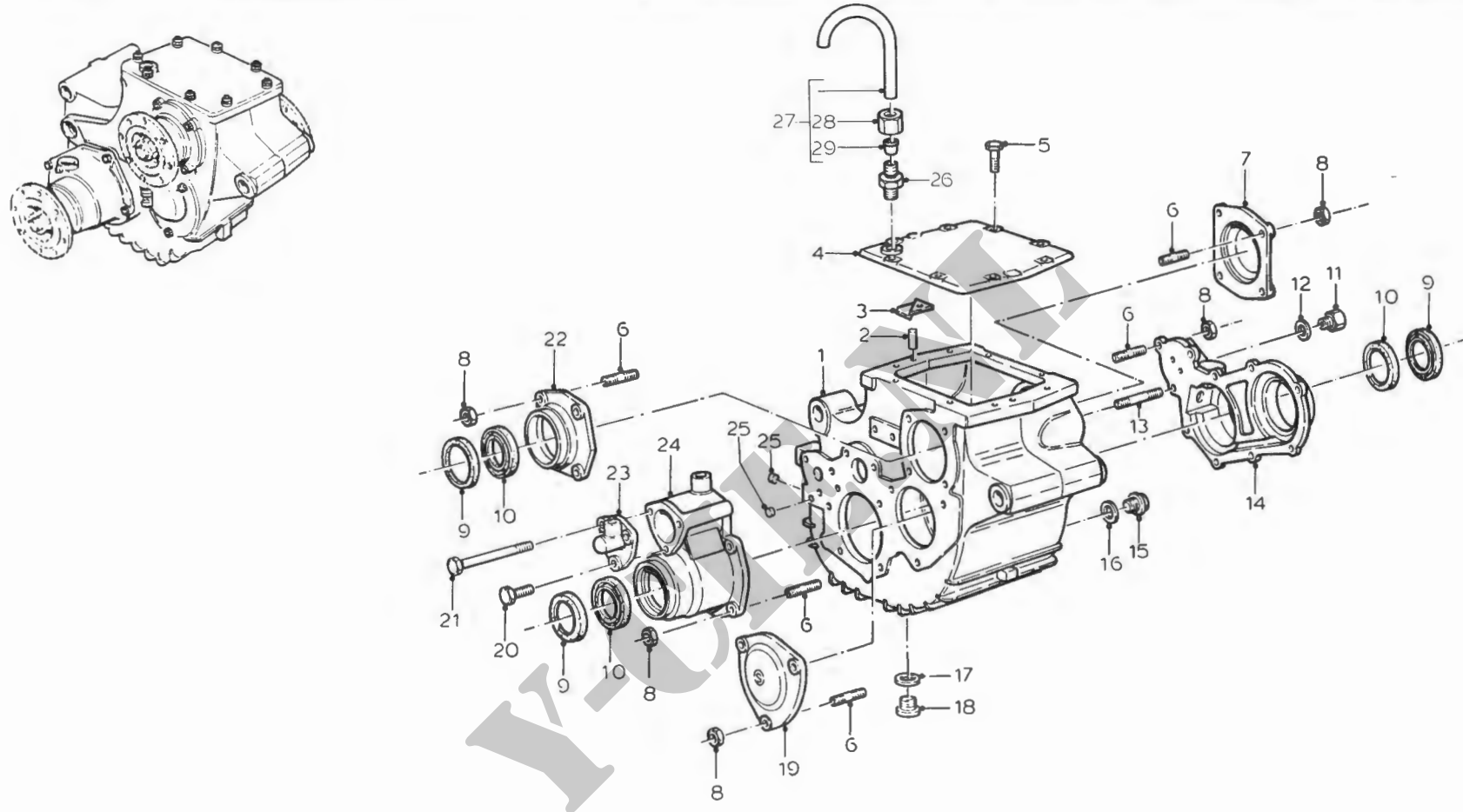

0801-0002

PN 002083

MOSNR 0801-0002

HUIS TUSSENBAK

DATUM: 890905

BLAD: 1

FIGNR	N	MC	B	NSN	C	FCN	REFERENTIENUMMER (= FAN)	ARTIKELOMSCHRIJVING TOELICHTING	AANT ECH	OPMERKINGEN
15			B	5365-17-103-2668	4	H0001	0066767 S3123 90003962030	STOP,CILINDRISCHE S	1 2	
16			B	5330-12-156-4527	7	H0001	0331331 D8286 DIN7603-A18X24-CU	GASKET	1 2	
17			B	5330-12-156-4529	9	H0001	0119133 D8286 DIN7603-A22X27-CU	GASKET	1 2	
18			B	5365-17-103-4429	5	H0001	0281264	STOP,CILINDRISCHE S	1 2	

KOCHER.MB

PN 002083

HUIS TUSSENBAK

MOSNR 0801-0002 BLAD: 1

**YCHIE.ME**

**KCH.ME**

PROJECTNUMMER: 002083  
MOSNUMMER : 0803-0002

SCHAKELMECHANISME (UITW.)

DATUM 871102  
BLAD 1 VAN 1 BLADEN

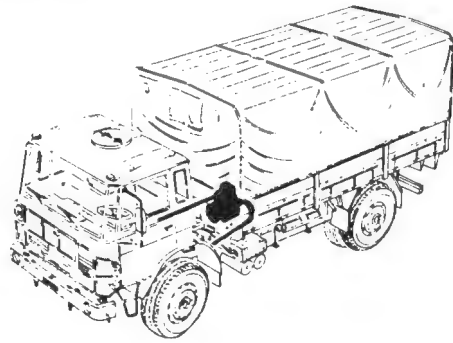

PN002083 MOS: 1202-0002

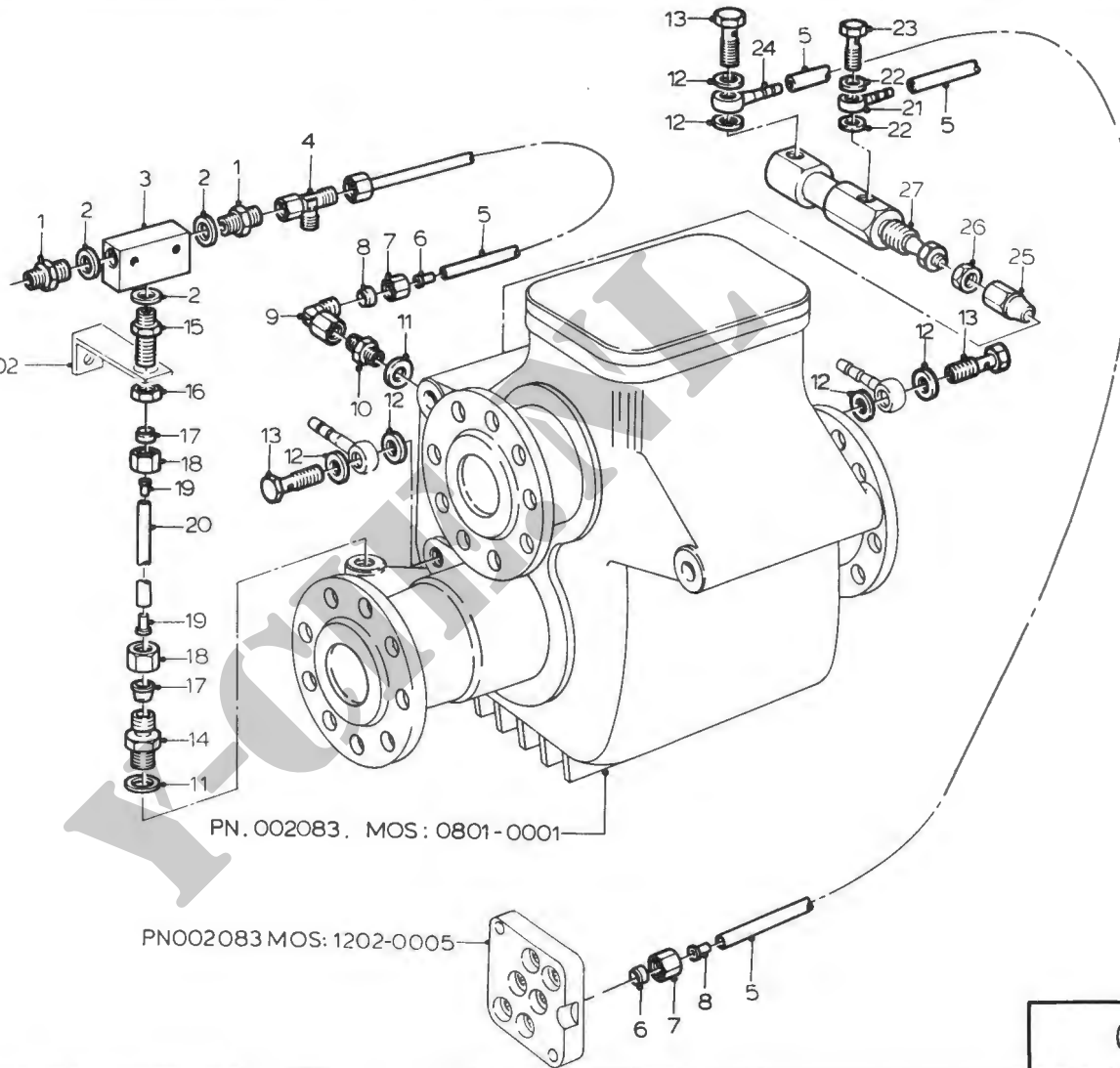

0803-0002

PN 002083

MOSNR 0803-0002

SCHAKELMECHANISME(UITW)

DATUM: 890905

BLAD: 1

FIGNR	N MC	B	NSN	C	FCN	REFERENTIENUMMER (= FAN)	ARTIKELOMSCHRIJVING TOELICHTING	AANT ECH	OPMERKINGEN
1		B	4730-17-103-3598	0	H0001	0369005	AANPASSTUK, RECHT	2 2	
2		B	5330-17-706-7593	0	H0001	0206784	PAKINGRING	3 2	
					H0001	0206784			
3		B	4810-17-915-1031	4	H0001	0272775	VENTIEL, TWEEWEG-	1 2	
					D8096	5340170090			
4		B	4730-17-103-1544	2	H0001	0369001	T-STUK, PIJP	1 2	
5		B	4720-12-173-8647	8	H0001	0799007	PYP, NIET METAAL	NB 2	MR
					D8286	DIN73378-PA11WSWLT-6X1			
6		B	4730-12-174-0669	6	H0001	0624109	HULS, TROMPETVORMIG,	3 2	
					D8096	8930402104			
7		B	4730-12-132-5661	6	H0001	0226483	MOER, PYPKOPPELING	3 2	
					D8286	DIN3870-AL6			
8		B	4730-12-132-5660	5	H0001	0624112	HULS, INPERS-, PYPFIT	3 2	
9		B	4730-17-101-5458	9	H0001	0285448	KNIE, PYP	1 2	
10		B	0000-KL-041-0507	9	H0001	0391265	KLEMK. MET EPOXYHAR	1 2	
11		B	5330-17-049-8488	6	H0001	0206786	PAKINGRING MET HOU	2 2	
					H0001	M12X1,5X16X2,5 DAFN.9105			
12		B	5330-12-156-4852	2	H0001	0326316	GASKET	6 2	
					D8286	DIN7603-A12X15,5-CU			
13		B	4730-12-124-1298	2	H0001	0243734	BOUT, BANJO	3 2	
					D8286	A6DIN7623-6-8			
14		B	0000-KL-041-0508	0	H0001	0375937	KLEMK. MET EPOXYHAR	1 2	
15		B	0000-KL-041-0509	0	H0001	0370843	KLEMK. MET EPOXYHAR	1 2	
16		B	5310-12-144-2164	8	H0001	0226491	MOER, ZESKANT	1 2	
					D8286	DIN80705-M14X1,5-A2P			
17		B	4730-12-136-8560	5	H0001	0633245	HULS, INPERS-, PYPFIT	2 2	
					D8286	DIN3861-L8-ST-A3P			
18		B	4730-12-124-4265	0	H0001	0205035	MOER, PYPKOPPELING	2 2	
					D8286	DIN3870-A18			
19		B	3120-17-054-6692	8	H0001	0633242	BUS, NAAFREDUCTIE	2 2	
					H0001	6X8X0,50X15 DAFN.9103			
20		B	4720-12-173-8649	0	H0001	0959033	PYP, NIET-METAAL	NB 2	MR
					D8286	DIN73378-PA11WSWLT-8X1			
21		B	4730-12-179-1616	1	H0001	0263256	AANSLUITSTUK, MEERVO	1 2	
					D9596	023522			
22		B	5330-12-156-4806	0	H0001	0331326	GASKET	2 2	
					D8286	DIN7603-A10X13,5-CU			
23		B	4730-12-158-8862	0	H0001	0232055	BOUT, BANJO	1 2	
					D8286	DIN7643-6			
24		B	4730-12-175-6826	4	H0001	0263257	AANSLUITSTUK, MEERVO	1 2	
					D9596	023682			

PN 002083

SCHAKELMECHANISME(UITW)

MOSNR 0803-0002 BLAD: 1

**YCHIE.ME**

**YCHIE.ME**

PROJECTNUMMER: 002083

MOSNUMMER : 0803-0004 VENTIEL, BEDIENING TUSSENBAK

DATUM 871102

BLAD 1 VAN 1 BLADEN

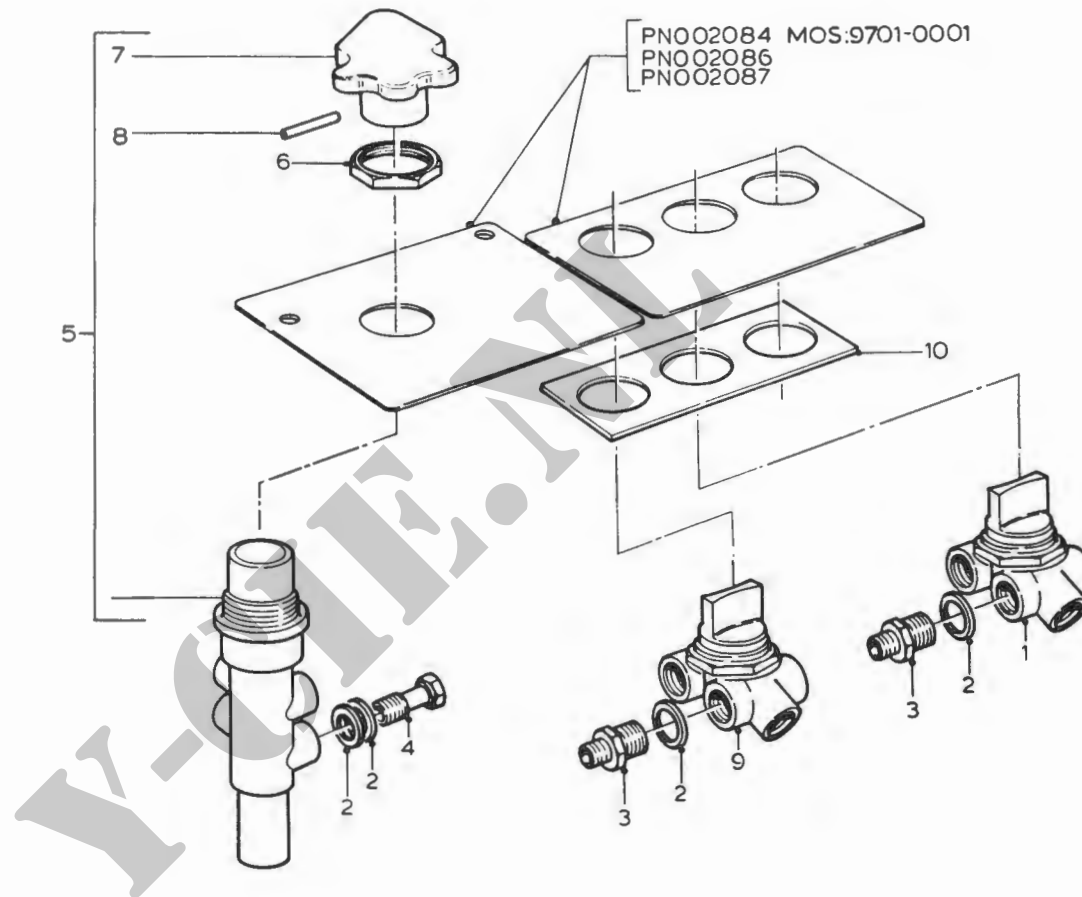
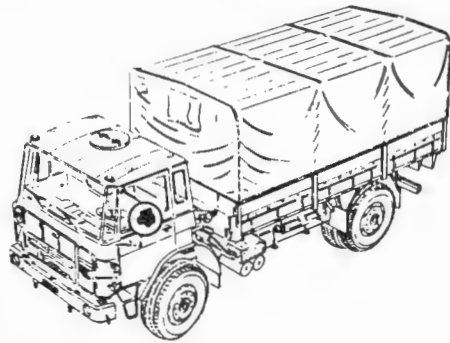

0803-0004

PN 002083

MOSNR 0803-0004

VENTIEL,BEDIENING TUSSENBAK

DATUM: 890905

BLAD: 1

FIGNR	N	MC	B	NSN	C	FCN	REFERENTIENUMMER (= FAN)	ARTIKELOMSCHRIJVING TOELICHTING	AANT	ECH	OPMERKINGEN
1			B	4820-12-199-8477	7	H0001	0266763 C1208 52042110	AFSLUITER, ROTERENDE	1	2	
2			B	5330-12-156-4806	0	H0001	0331326 D8286 DIN7603-A10X13,5-CU	GASKET	3	2	
3			B	4730-17-102-9690	7	H0001	0373011	NIPPEL, PIJP	1	2	
4			B	4730-12-158-8862	0	H0001	0232055 D8286 DIN7643-6	BOUT, BANJO	4	2	
5			B	2910-17-910-7213	0	H0001	0393516	VENTIEL, BEDIENINGS-	1	2	R
6			B	5310-17-049-6958	5	H0001	0507166	MOER, ZESKANT	1	2	
											0803/0004/00005
7			B	2530-12-174-1172	3	H0001	0617950 D8096 8998518104	GRIFF	1	2	
											0803/0004/00005
8			B	5315-12-138-4407	1	H0001	0067601 D8286 DIN1481-2,5X24	PEN, HOL, VEREND	1	2	
											0803/0004/00005
9			B	0000-KL-044-0798	6	H0001	0266764 C1208 51942106	VENTIEL, BEDIENINGS-	1	2	
10			B	2590-17-055-1029	0	H0001	0277834	PLAAT	1	2	

PN 002083

VENTIEL,BEDIENING TUSSENBAK

MOSNR 0803-0004 BLAD: 1

**Y-CHE.ME**

**Y-CHE.ME**

PROJECTNUMMER: 002083

MOSNUMMER : 0804-0001

TUSSENASSEN

DATUM 871102

BLAD 1 VAN 1 BLADEN

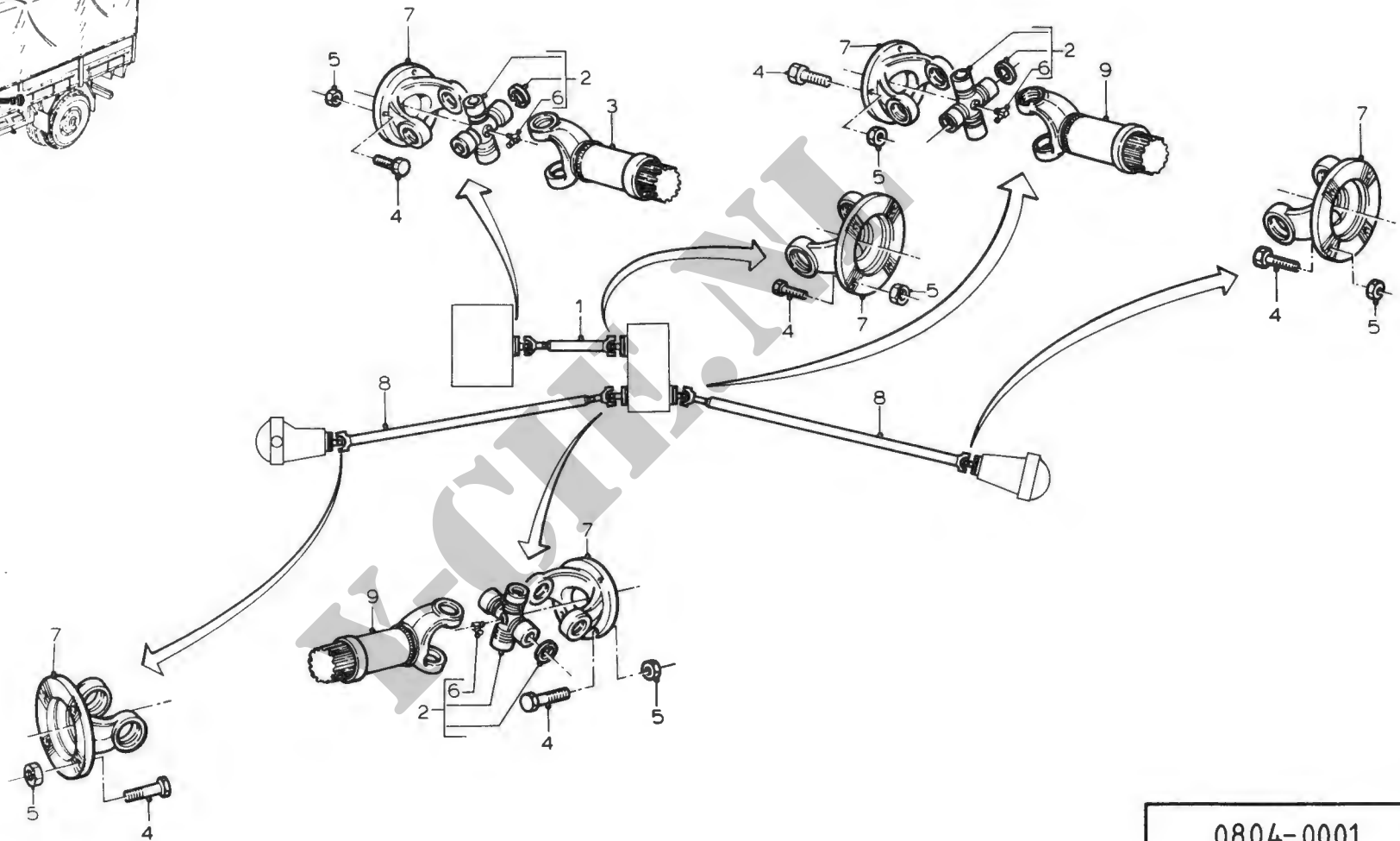
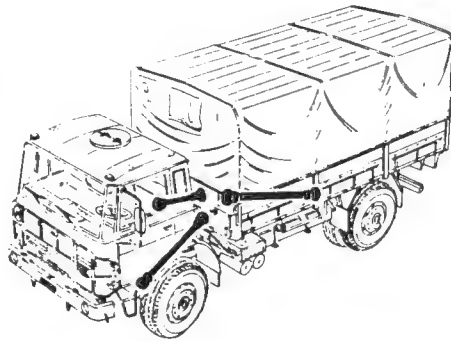

0804-0001

PN 002083

MOSNR 0804-0001

TUSSENASSEN

DATUM: 890905

BLAD: 1

FIGNR	N	MC	B	NSN	C	FCN	REFERENTIENUMMER (= FAN)	ARTIKELOMSCHRIJVING TOELICHTING	AANT ECH	OPMERKINGEN
1			B	0000-KL-041-0530	0	H0001	0558012 D8047 587.15K	AS, AANDRIJF-(HOOFD)	1	2
4			B	5305-12-156-4858	8	H0001	0251635 D8286 DIN933-M10X35-8.8-A3P	SCHROEF, ZESKANTE KO	NB	2
5			B	5310-12-156-4996	3	H0001	0251276 D8286 DIN934-M10-8-A2P	MOER, ZESKANT	NB	2
6			B	4730-12-124-2518	1	H0001	0204421 D8286 DIN71412-CM10X1	NIPPEL, SMEER-	NB	2
8			B	0000-KL-041-0533	2	H0001	0558058	AS, AANDRIJF-(HOOFD)	0804/0001/00002 2 2	

PN 002083

TUSSENASSEN

MOSNR 0804-0001 BLAD: 1

54

-LAATSTE BLAD-

**KCH.ME**

**Y-CHE.ME**

PROJECTNUMMER: 002083  
MOSNUMMER : 0805-0002

VOORASLICHAAM

DATUM 871102  
BLAD 1 VAN 1 BLADEN

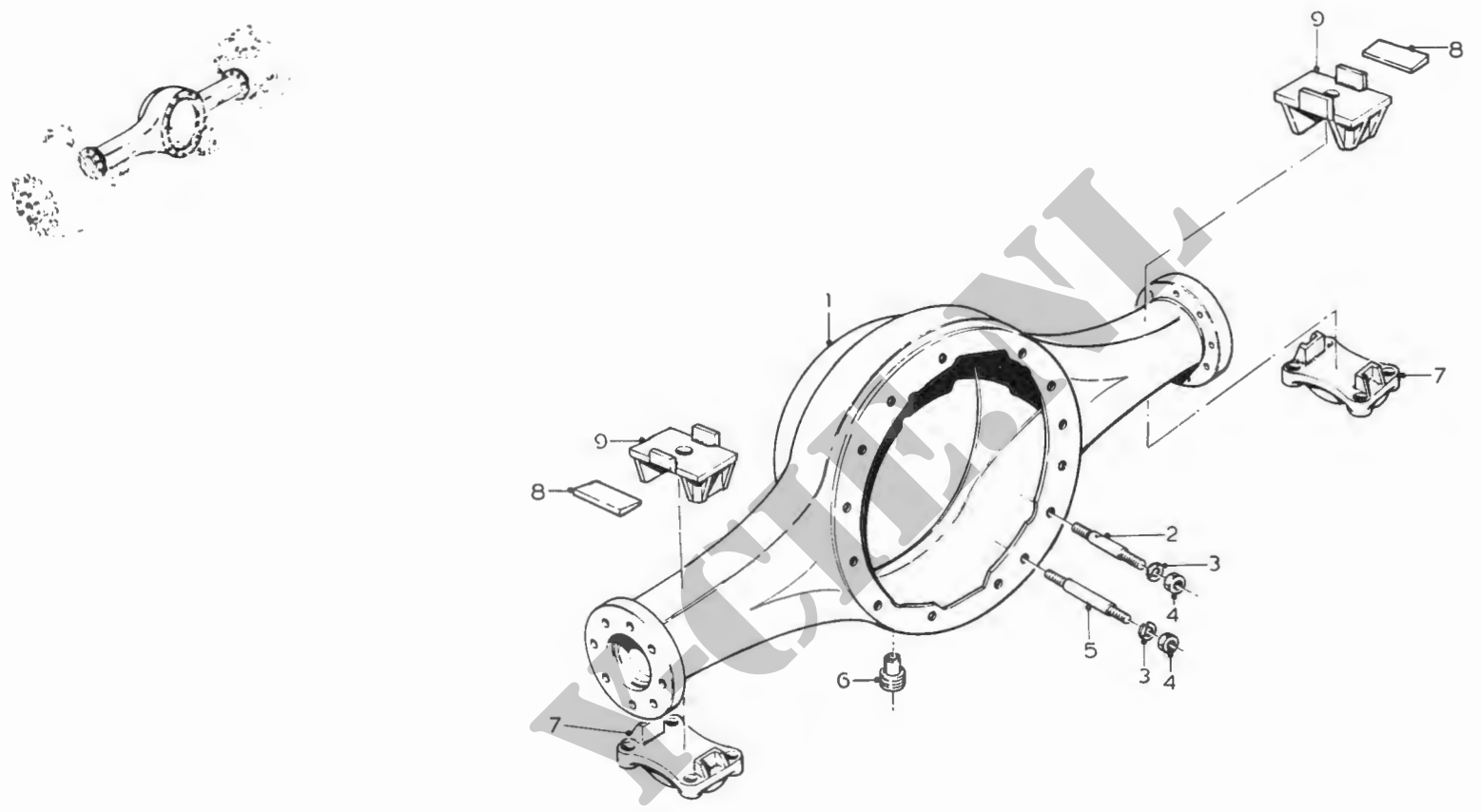

0805-0002

PN 002083

MOSNR 0805-0002

VOORASLICHAAM

DATUM: 890905 BLAD: 1

FIGNR N MC B NSN C FCN REFRENTIENUMMER (= FAN)

ARTIKELOMSCHRIJVING TOELICHTING AANT ECH OPMERKINGEN

6 B 5340-17-054-2042 0 H0001 0542176

PLUG, MAGNETISCH 1 2

V-CHE.ML

PN 002083

VOORASLICHAAM

MOSNR 0805-0002 BLAD: 1

55

-LAATSTE BLAD-

**Y-CHE.ME**

**Y-CHE.ME**

PROJECTNUMMER: 002083  
MOSNUMMER : 0805-0003

DIFF. VOORAS

DATUM 871102  
BLAD 1 VAN 1 BLADEN

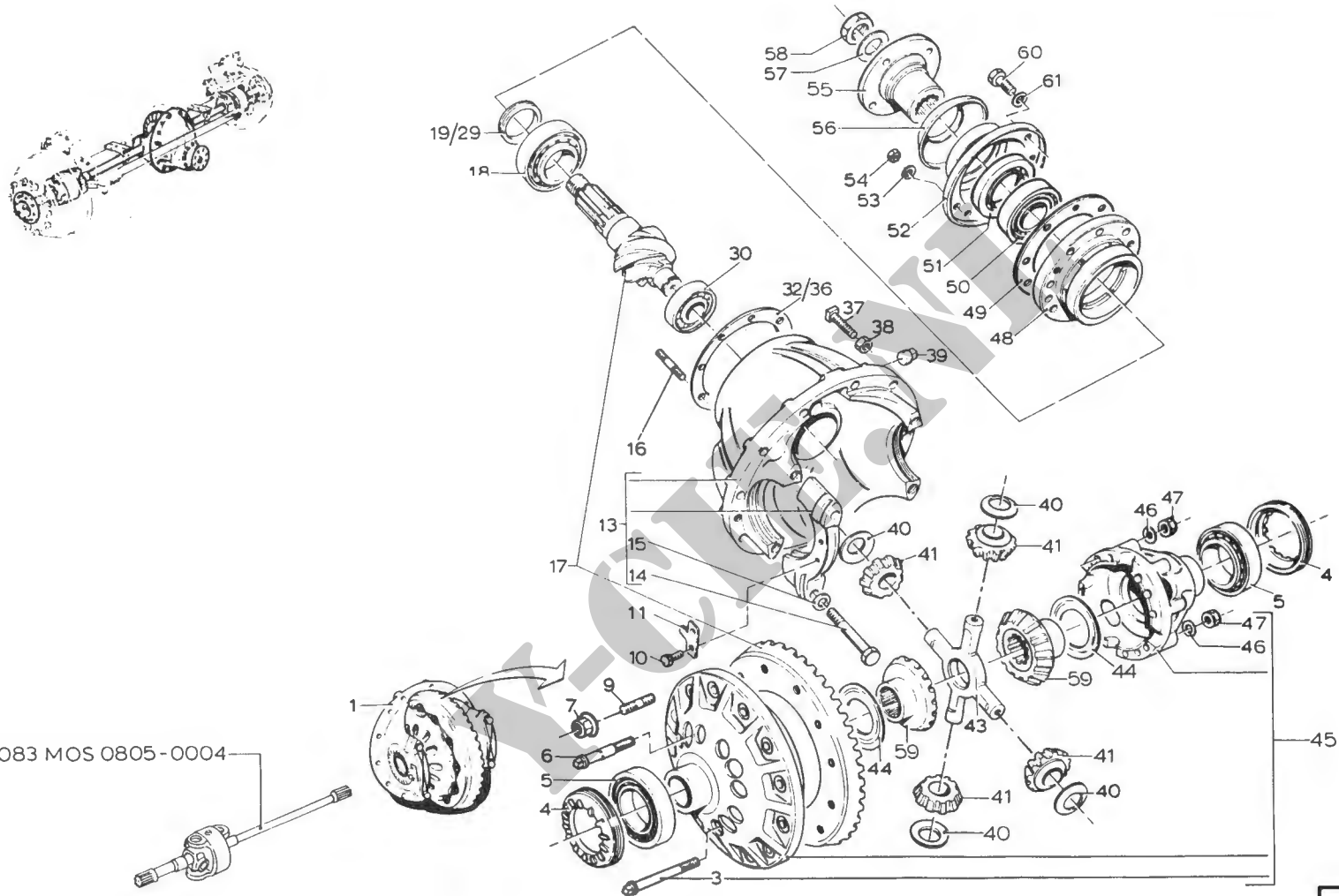

PN 002083 MOS 0805-0004

0805-0003

PN 002083

MOSNR 0805-0003

DIFF. VOORAS

DATUM: 890905 BLAD: 1

FIGNR N MC B NSN C FCN REFERENTIENUMMER (= FAN)

ARTIKELOMSCHRIJVING TOELICHTING AANT ECH OPMERKINGEN

39 B 4730-00-826-6512 1 H0001 0119068

STOP,BUIS 1 2

YCHIE.ML

PN 002083

DIFF. VOORAS

MOSNR 0805-0003 BLAD: 1

56

-LAATSTE BLAD-

**Y-CHE.ME**

**YCHIE.ME**

PROJECTNUMMER: 002083

MOSNUMMER : 0806-0002

ACHTERASLICHAAM

DATUM 871102

BLAD 1 VAN 1 BLADEN

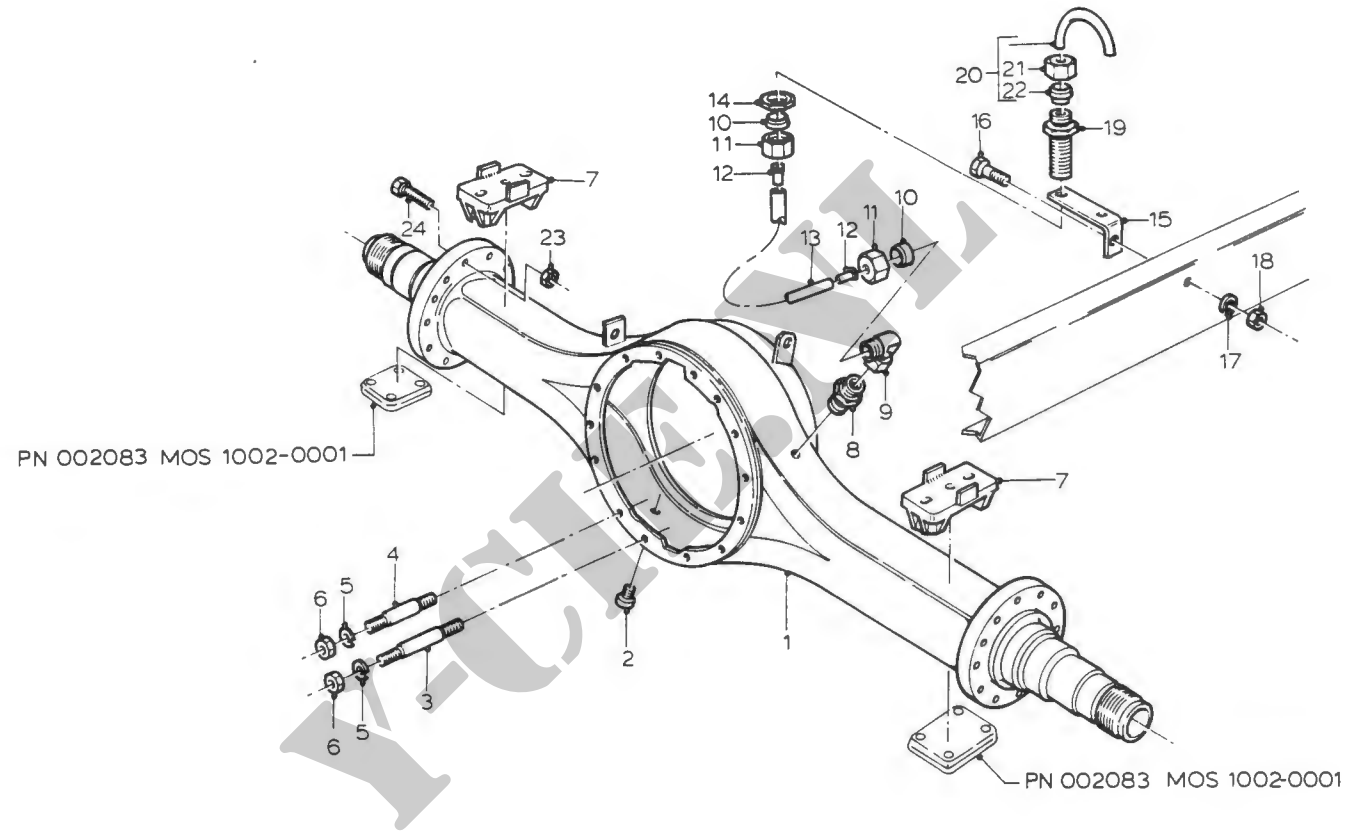

0806-0002

PN 002083

MOSNR 0806-0002

ACHTERASLICHAAM

DATUM: 890905 BLAD: 1

FIGNR	N MC	B	NSN	C	FCN	REFERENTIENUMMER (= FAN)	ARTIKELOMSCHRIJVING TOELICHTING	AANT ECH	OPMERKINGEN
2		B	5340-17-054-2042	0	H0001	0542176	PLUG, MAGNETISCH	1 2	
8		B	4730-17-101-5679	0	H0001	0373018	AANPASSTUK, RECHT	1 2	
9		B	4730-17-101-5285	1	H0001	0285443	KNIE, PYP	1 2	
10		B	4730-12-172-1015	9	H0001	0624113	HULS, COMPRESSIE, PYP	2 2	
					D9596	022065			
11		B	4730-12-123-4179	0	H0001	0146142	MOER, PYPKOPPELING	2 2	
					D8286	DIN3870-AL10			
12		B	4730-17-050-2609	2	H0001	0624110	VERSTERKINGSHUIS	2 2	
					H0001	7,5X10X0,75X15DAFN.9103			
13		B	4720-12-317-5828	6	H0001	0799005	SLANG, NIET-METAAL	NB 2	MR
					D8286	DIN74324-10X1,25			
14		B	5310-12-145-2077	0	H0001	0107233	MOER, ZESKANT	1 2	
					D8286	DIN80705-M16X1,5-A2P			
16		B	5305-12-156-4870	9	H0001	0251624	SCHROEF, ZESKANTE KO	1 2	
					D8286	DIN933-M8X30-8.8-A2P			
17		B	5310-12-162-2131	4	H0001	0251928	ONDERLEGRING, BORG-	1 2	
					D8286	DIN128-A8			
18		B	5310-12-144-6214	0	H0001	0251275	MOER, ZESKANT	1 2	
					D8286	DIN934-M8-8-A2P			
19		B	4730-17-101-5637	1	H0001	0368995	NIPPEL, PYP	1 2	
20		B	4710-17-050-3072	3	H0001	0622143	PYP, METAAL	1 2	
21		B	4730-12-123-4179	0	H0001	0146142	MOER, PYPKOPPELING	1 2	
					D8286	DIN3870-AL10			
22		B	4730-12-137-6457	4	H0001	0146141	HULS, INPERS-, PYPFIT	0806/0002/00020	
					D8286	DIN3861-L10-ST-A3P		1 2	
								0806/0002/00020	

PN 002083

ACHTERASLICHAAM

MOSNR 0806-0002 BLAD: 1

57

-LAATSTE BLAD-

**Y-CHE.ME**

**Y-CHE.ME**

PROJECTNUMMER: 002083  
MOSNUMMER : 0806-0003

DIFF.ACHTERAS

DATUM 871102  
BLAD 1 VAN 1 BLADEN

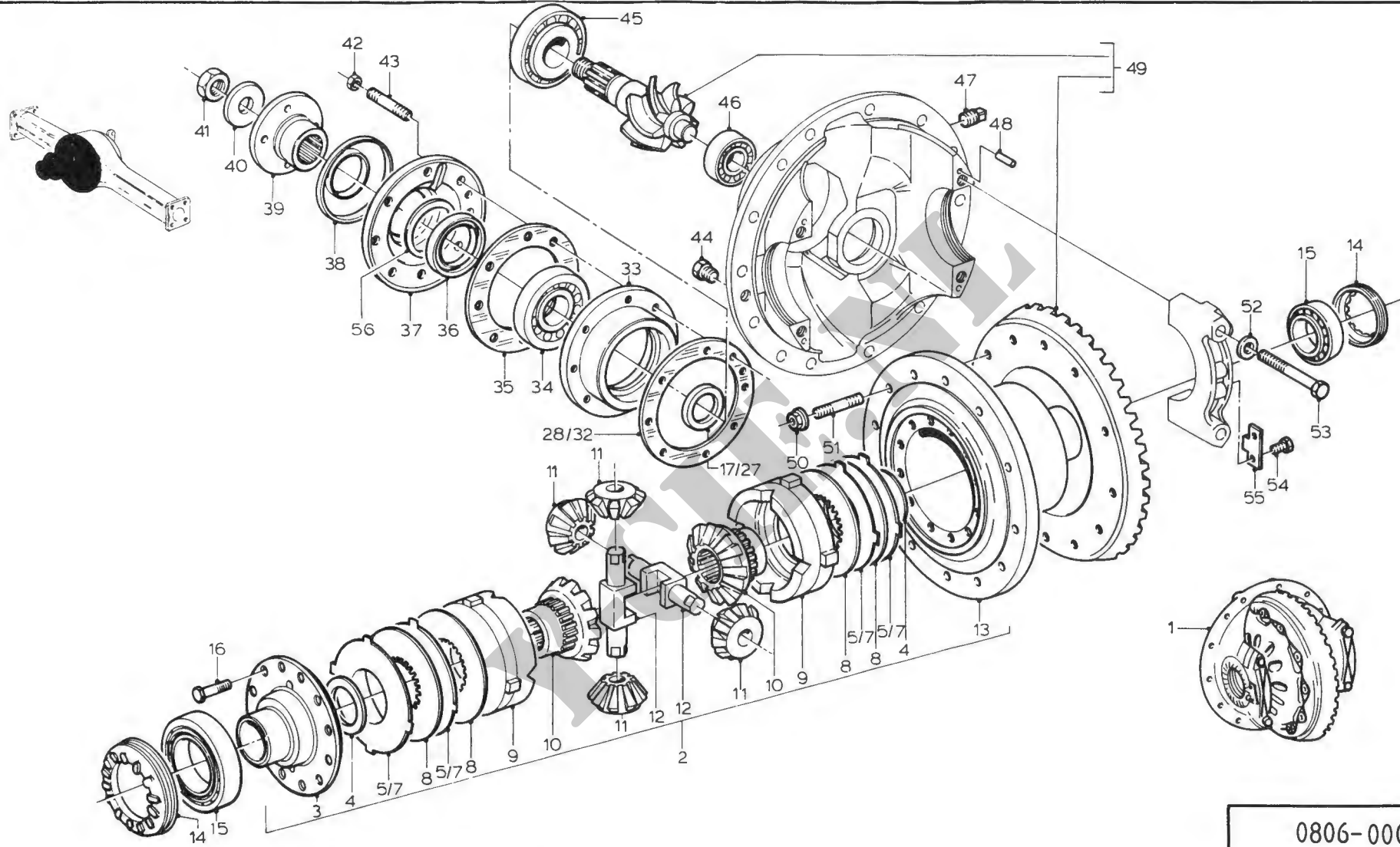

0806-0003

PN 002083

MOSNR 0806-0003

DIFF.ACHTERAS

DATUM: 890905 BLAD: 1

FIGNR	N	MC	B	NSN	C	FCN	REFERENTIENUMMER (= FAN)
47			B	4730-00-826-6512	1	H0001 79218	0119068 W6512

ARTIKELOMSCHRIJVING	TOELICHTING	AANT ECH	OPMERKINGEN
STOP,BUIS		1 2	

Y-CHE.ML

PN 002083

DIFF.ACHTERAS

MOSNR 0806-0003 BLAD: 1

**KCH.ME**

van Hest W.G.J.  
Jan de Rooft  
5171 DR Kaatsheuvel  
0418 - 275763

**Y-CHE.ME**

PROJECTNUMMER: 002083  
MOSNUMMER : 0806-0004

A ANDRIJFASSEN IN ACHTERAS

DATUM 871102  
BLAD 1 VAN 1 BLADEN

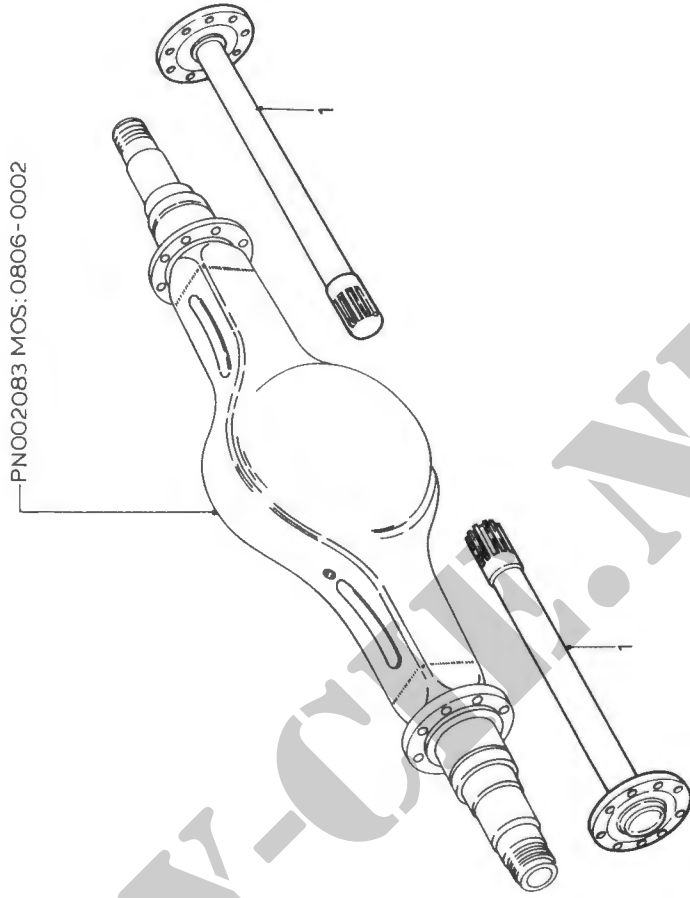
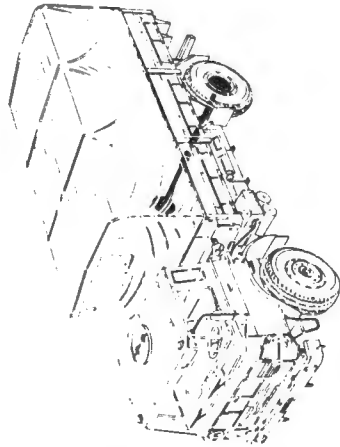

0806-0004

PN 002083

MOSNR 0806-0004

AANDRIJFASSEN IN ACHTERAS

DATUM: 890905 BLAD: 1

FIGNR	N	MC	B	NSN	C	FCN	REFERENTIENUMMER (= FAN)	ARTIKELOMSCHRIJVING TOELICHTING	AANT ECH	OPMERKINGEN
1				B 2520-17-103-2567	2	H0001	0526658	AS (1), AANDRIJVING	2	2

Y-CHE.ML

PN 002083

AANDRIJFASSEN IN ACHTERAS

MOSNR 0806-0004 BLAD: 1

**YCHIE.ME**

**YCHIE.ME**

PROJECTNUMMER: 002083  
MOSNUMMER : 0901-0001

FUSEE-, STUUR-, SPOORSTANGARMEN

DATUM 871102  
BLAD 1 VAN 1 BLADEN

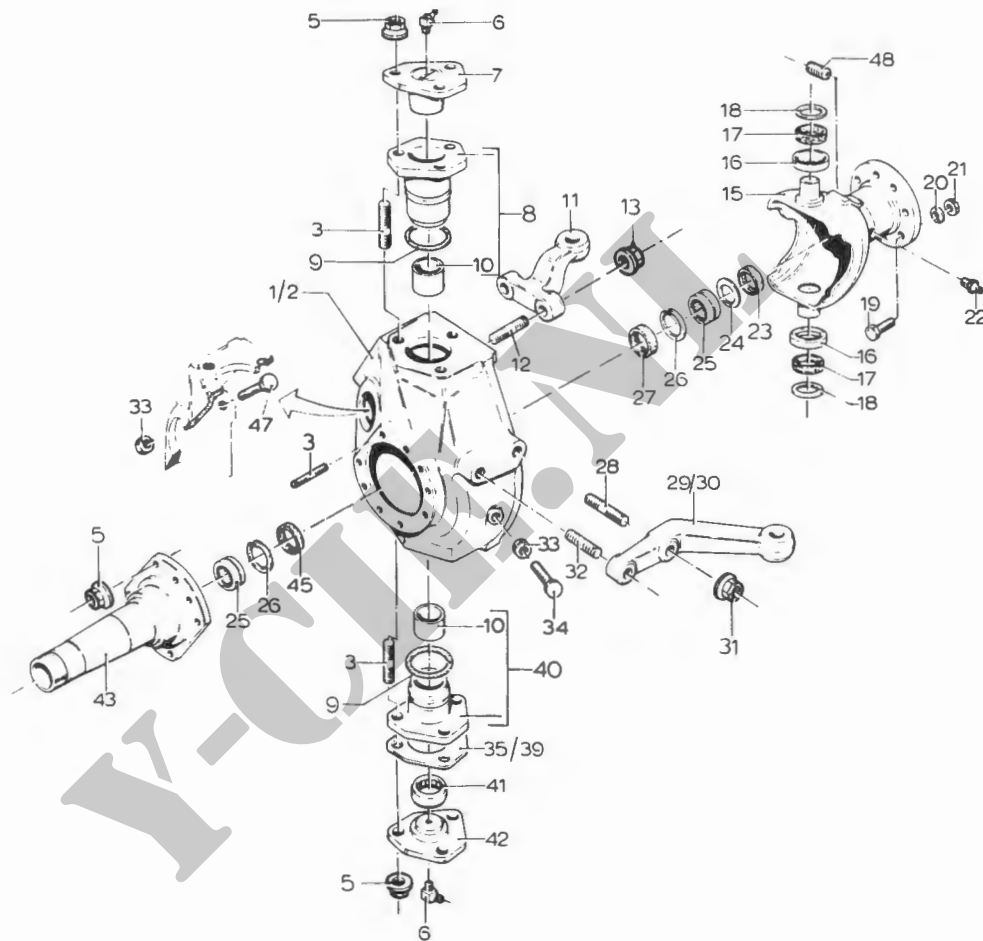

0901-0001

PN 002083

MOSNR 0901-0001

FUSEE-, STUUR-, SPOORSTANGARMEN

DATUM: 890905

BLAD: 1

FIGNR	N	MC	B	NSN	C	FCN	REFERENTIENUMMER (= FAN)	ARTIKELOMSCHRIJVING TOELICHTING	AANT ECH	OPMERKINGEN
6			B	4730-12-124-1174	0	H0001	0214740	NIPPEL, SMEER-	4	2
						D8286	DIN71412-BM8X1			
22			B	4730-12-125-0313	8	H0001	0202864	NIPPEL, SMEER-	2	2
						D8286	DIN71412-AM8X1			

YCHIE.ML

PN 002083

FUSEE-, STUUR-, SPOORSTANGARMEN

MOSNR 0901-0001 BLAD: 1

60

-LAATSTE BLAD-

**Y-CHE.ME**

**YCHIE.ME**

PROJECTNUMMER: 002083  
MOSNUMMER : 0902-0001

NAAF EN REMTROMMEL VOORAS

DATUM 871102  
BLAD 1 VAN 1 BLADEN

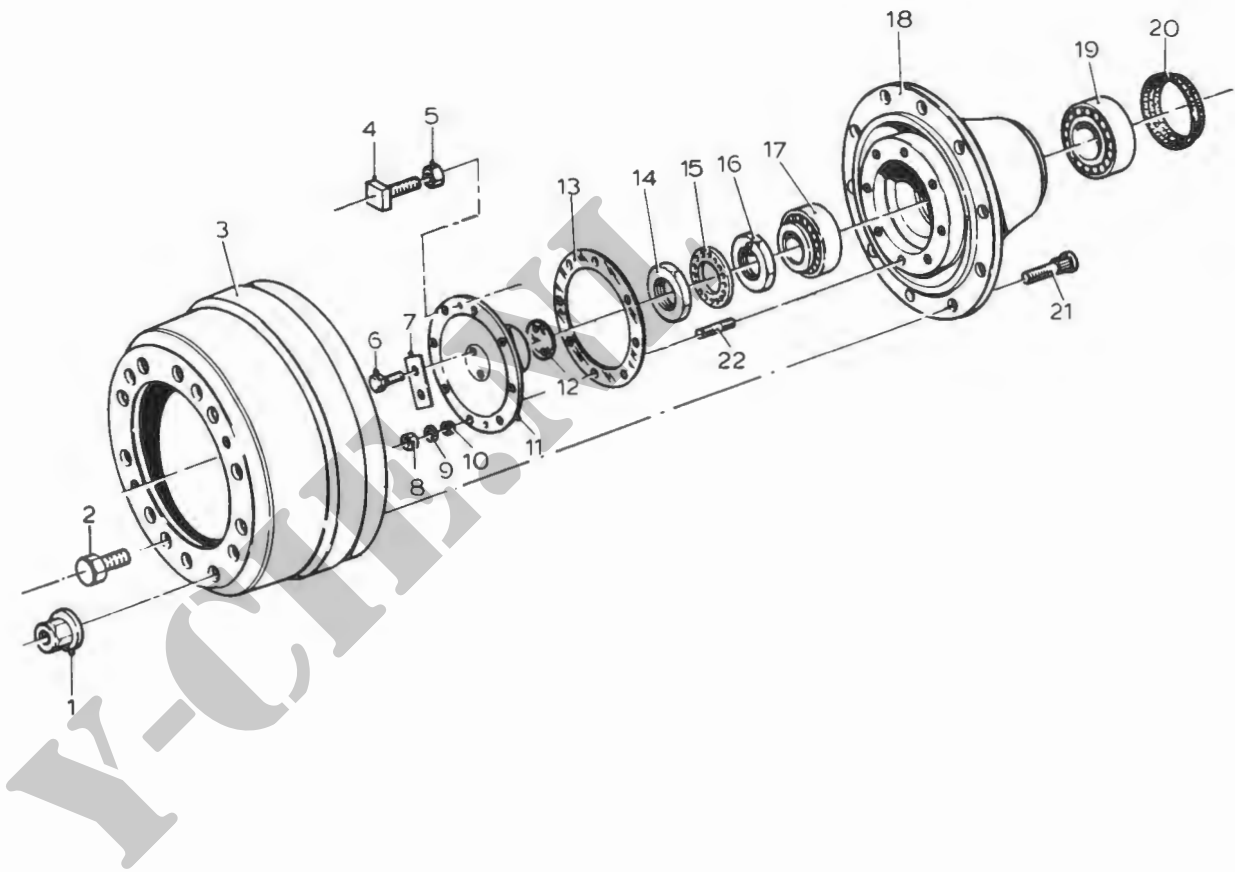
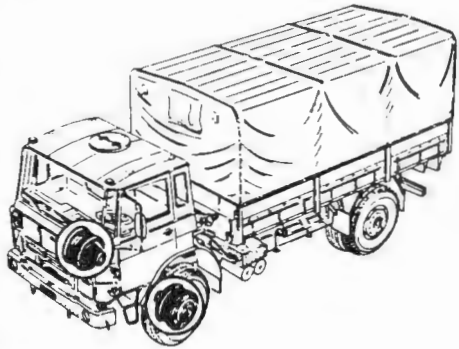

0902-0001

PN 002083

MOSNR 0902-0001

NAAF EN REMTROMMEL VOORAS

DATUM: 890905

BLAD: 1

FIGNR	N MC	B	NSN	C	FCN	REFERENTIENUMMER (= FAN)	ARTIKELOMSCHRIJVING TOELICHTING	AANT ECH	OPMERKINGEN
1		B	5310-17-054-3357	6	H0001	0652575	MOER, GEASSEMBLEERD	20 2	
2		B	5305-12-156-4874	2	D8286	DIN933-M12X20-8.8-A3P	SCHROEF, ZESKANTE KO	8 2	
4		B	5305-00-017-9116	3	H0001	0121177	STEL SCHROEF	4 2	
						D3057 NR S978			
5		B	5310-00-891-1711	6	H0001	0251268	MOER, ZESKANT	4 2	
						96906 MS35691-25			
6		B	5305-12-158-9470	2	D8286	DIN933-M10X16-10.9-A3P	SCHROEF, ZESKANTE K	4 2	**
7		B	5340-17-049-5648	4	H0001	0100589	PLAAT, BORG-, BOUT EN	2 2	
8		B	5310-00-732-0560	5	H0001	0251289	MOER, ZESKANT	16 2	
						96906 MS51968-14			
9		B	5310-12-156-4899	5	D8286	DIN125-B13-ST-A3P	ONDERLEGRING, VLAK	2 2	
10		B	5365-00-392-4479	9	H0001	0324029	BUS, TAPS	16 2	
11		B	2520-17-049-7655	9	H0001	0582307	FLENS, AS	2 2	
12		B	5330-17-710-2240	7	H0001	0588980	GASKET	2 2	
13		B	5330-17-705-9590	4	H0001	0190111	GASKET	2 2	
14		B	5310-17-026-3039	1	H0001	0218592	MOER, ZESKANT	2 2	
15		B	5310-17-710-1750	1	H0001	0546307	ONDERLEGRING, LIP	2 2	
16		B	5310-17-710-1748	0	H0001	0546308	MOER, ZELFBORGEND, ZE	2 2	
17		B	3110-12-308-3133	8	H0001	0655403	LAGER, ROL, CONISCH	2 2	
						D2456 545084			
19		B	3110-12-170-1149	9	H0001	0655407	LAGER, ROL, CONISCH	2 2	
20		B	5330-17-710-1740	2	H0001	0500162	AFDICHTING, BEMANTEL	2 2	
21		B	5306-17-102-0490	3	H0001	0620646	BOUT, GERIBDE BORST	20 2	
22		B	5307-17-102-9323	3	H0001	0364772	TAPEIND, CILINDRISCH	16 2	

PN 002083

NAAF EN REMTROMMEL VOORAS

MOSNR 0902-0001 BLAD: 1

**KCH.ME**

**Y-CHE.ME**

PROJECTNUMMER: 002083  
MOSNUMMER : 0902-0002

NAAF EN REMTROMMEL ACHTERAS

DATUM 871102  
BLAD 1 VAN 1 BLADEN

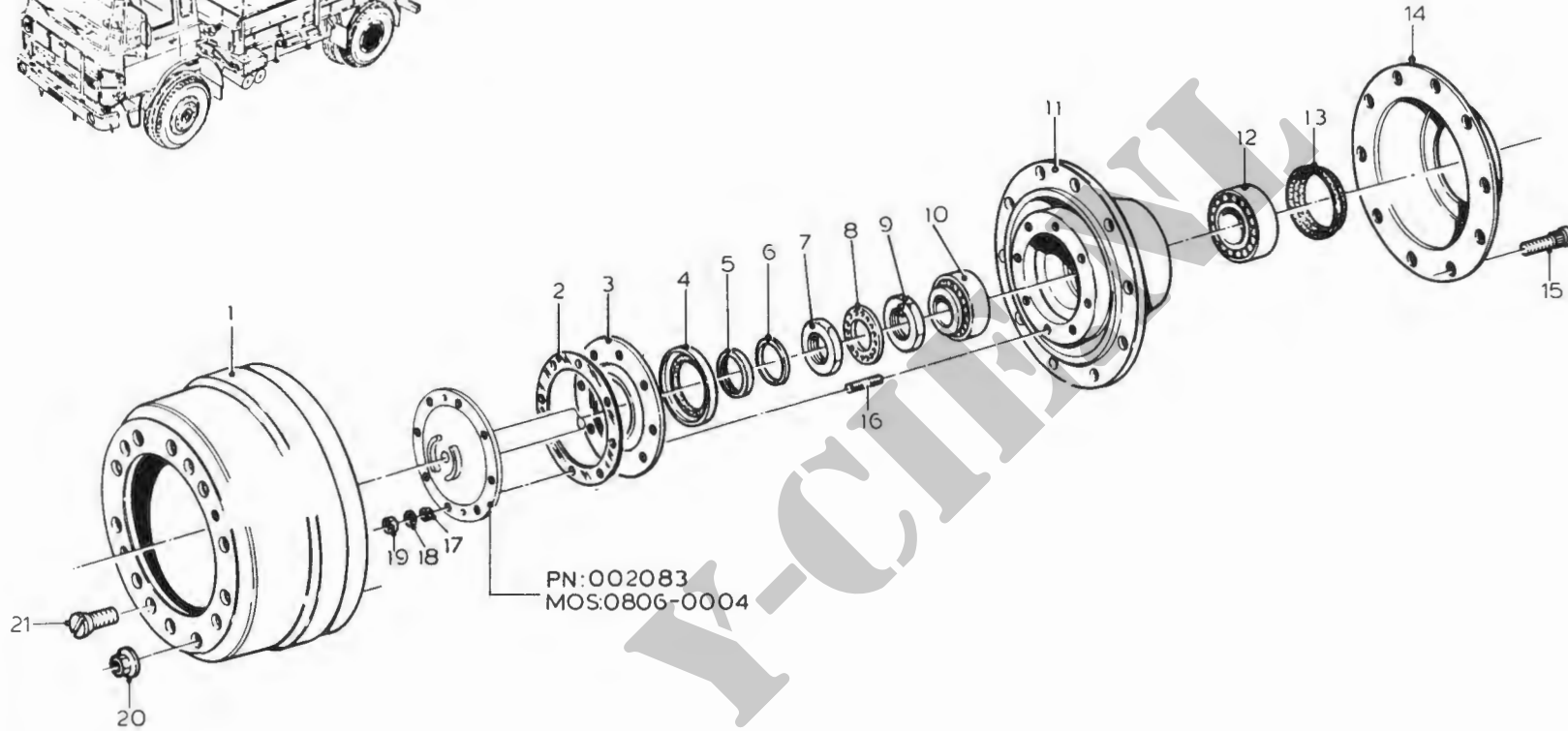
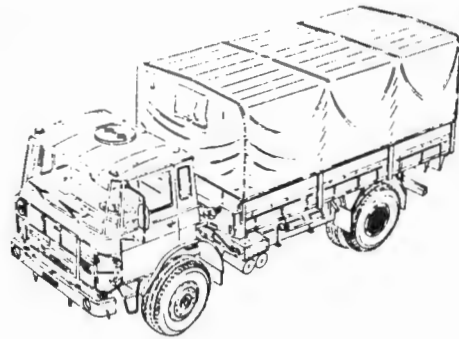

PN:002083  
MOS:0806-0004

0902-0002

PN 002083

MOSNR 0902-0002

NAAF EN REMTROMMEL ACHTERAS

DATUM: 890905

BLAD: 1

FIGNR	N MC	B	NSN	C	FCN	REFERENTIENUMMER (= FAN)	ARTIKELOMSCHRIJVING TOELICHTING	AANT ECH	OPMERKINGEN
2		B	5330-17-705-9590	4	H0001	0190111	GASKET	4 2	
					H0711	SV1G13225			
3		B	5330-17-705-9591	5	H0001	0190112	HOUDER, PAKKING	2 2	
4		B	5330-17-705-9607	0	H0001	0325321	AFDICHTING, ONBEMANT	2 2	
5		B	5310-17-705-9588	2	H0001	0190068	ONDERLEGRING, VERZON	2 2	
6		B	5330-17-705-9589	3	H0001	0190078	GASKET	2 2	
7		B	5310-17-705-9585	0	H0001	0190064	MOER, ZESKANT	2 2	
8		B	5310-17-705-9587	1	H0001	0190066	ONDERLEGRING, LIP	2 2	
9		B	5310-17-708-6844	0			MOER, ZESKANT, ST,	2 2	
10		B	3110-12-193-1249	0	H0001	0681785	LAGER, ROL, CONISCH	2 2	
11		B	2530-17-102-8022	0	H0001	0298711	NAAF, LICHAAM	2 2	
12		B	3110-12-190-0013	4	H0001	0174595	LAGER, ROL, CONISCH	2 2	
13		B	5330-17-103-2459	4	H0001	0592072	AFDICHTING, BEMANTEL	2 2	
15		B	5306-17-102-6654	7	H0001	0620648	BOUT, GERIBDF. BORST	20 2	
16		B	5307-17-102-9323	3	H0001	0364772	TAPEIND, CILINDRISCH	16 2	
					H0001	0364772			
17		B	5365-00-392-4479	9	H0001	0324029	BUS, TAPS	16 2	
19		B	5310-00-732-0560	5	H0001	0251289	MOER, ZESKANT	16 2	
					H0001	MS51968-14			
20		B	5310-17-054-3357	6	H0001	0652575	MOER, GEASSEMBLEERD	20 2	
21		B	5305-00-781-3924	8	H0001	0251541	SCHROEF, ZESKANTE KO	4 2	
					96906	MS90725-107			

PN 002083

NAAF EN REMTROMMEL ACHTERAS

MOSNR 0902-0002 BLAD: 1

**Y-CHE.ME**

PN 002083

MOSNR 0902-0003

REMTROMMELASSET, VOORAS, DR

DATUM: 890905 BLAD: 1

FIGNR	N	MC	B	NSN	C	FCN	REFERENTIENUMMER (= FAN)	ARTIKELOMSCHRIJVING TOELICHTING	AANT ECH	OPMERKINGEN
1			B	2530-17-102-5876	0	H0001 H9531	0682195 SL2530-2-131-043	REMTROMMELASSET, VA	1 2	DR

Y-CHE.ML

PN 002083

REMTROMMELASSET, VOORAS, DR

MOSNR 0902-0003 BLAD: 1

**Y-CHE.ME**

PN 002083

MOSNR 0902-0004

REMTROMMELASSET, ACHTERAS, DR

DATUM: 890905 BLAD: 1

FIGNR	N	MC	B	NSN	C	FCN	REFERENTIENUMMER (= FAN)	ARTIKELOMSCHRIJVING TOELICHTING	AANT ECH	OPMERKINGEN
1				B 2530-17-102-5875	9	H0001 H9531	0682196 SL2530-2-131-044	REMTROMMELASSET, AA	1 2	DR

Y-CHE.ML

PN 002083

REMTROMMELASSET, ACHTERAS, DR

MOSNR 0902-0004 BLAD: 1

64

-LAATSTE BLAD-

**Y-CHE.ME**

**YCHIE.ME**

PROJECTNUMMER: 002083  
MOSNUMMER : 0904-0001

BANDEN EN VELGEN

DATUM 871102  
BLAD 1 VAN 1 BLADEN

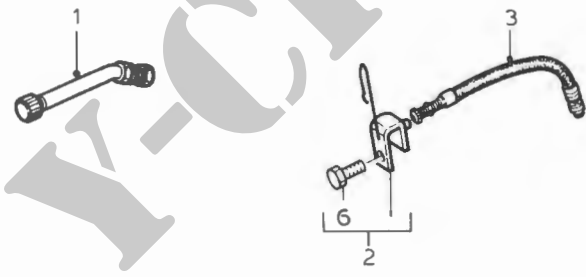
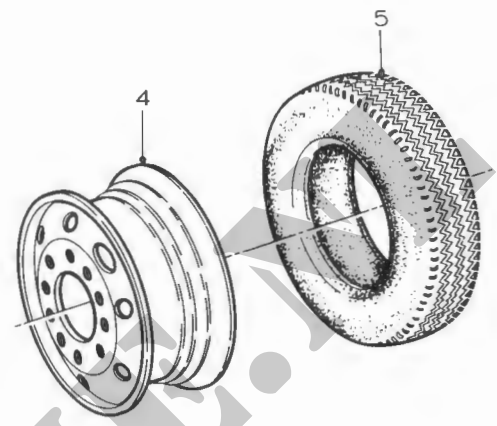
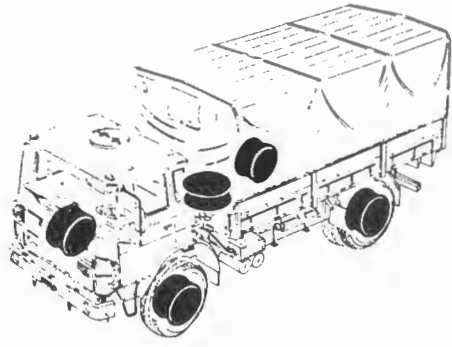

0904-0001

PN 002083

MOSNR 0904-0001

BANDEN EN VELGEN

DATUM: 890905 BLAD: 1

FIGNR	N	MC	B	NSN	C	FCN	REFERENTIENUMMER (= FAN)	ARTIKELOMSCHRIJVING TOELICHTING	AANT	ECH	OPMERKINGEN
1			B	2640-14-385-9220	0			VENTIEL, LUCHTBAND	7	2	
2			B	5340-14-381-5147	3	H0001	0105011	ANKERSTRIP	2	2	
						H2321	1144				
3			B	2640-14-371-1863	9	H0001	0105010	VENTIELVERLENGSTUK,	2	2	HB
						H2321	723				
5			B	2610-17-055-4288	3	H6142	13R22,5 154/149J	BAND, LUCHT, BUITEN	6	2	R
						H2321	13R22,5 154/149J XZY				
6			B	5305-12-156-4862	1	H0001	0251612	SCHROEF, ZFSKANTE KO	2	2	
						D8286	DIN933-M6X20-8.8-A2P				

0904/0001/00002

PN 002083

BANDEN EN VELGEN

MOSNR 0904-0001 BLAD: 1

65

-LAATSTE BLAD-

**Y-CHE.ME**

**Y-CHE.ME**

PROJECTNUMMER: 002083  
MOSNUMMER : 1001-0001

VOORVEER EN OPHANGING

DATUM 871102  
BLAD 1 VAN 1 BLADEN

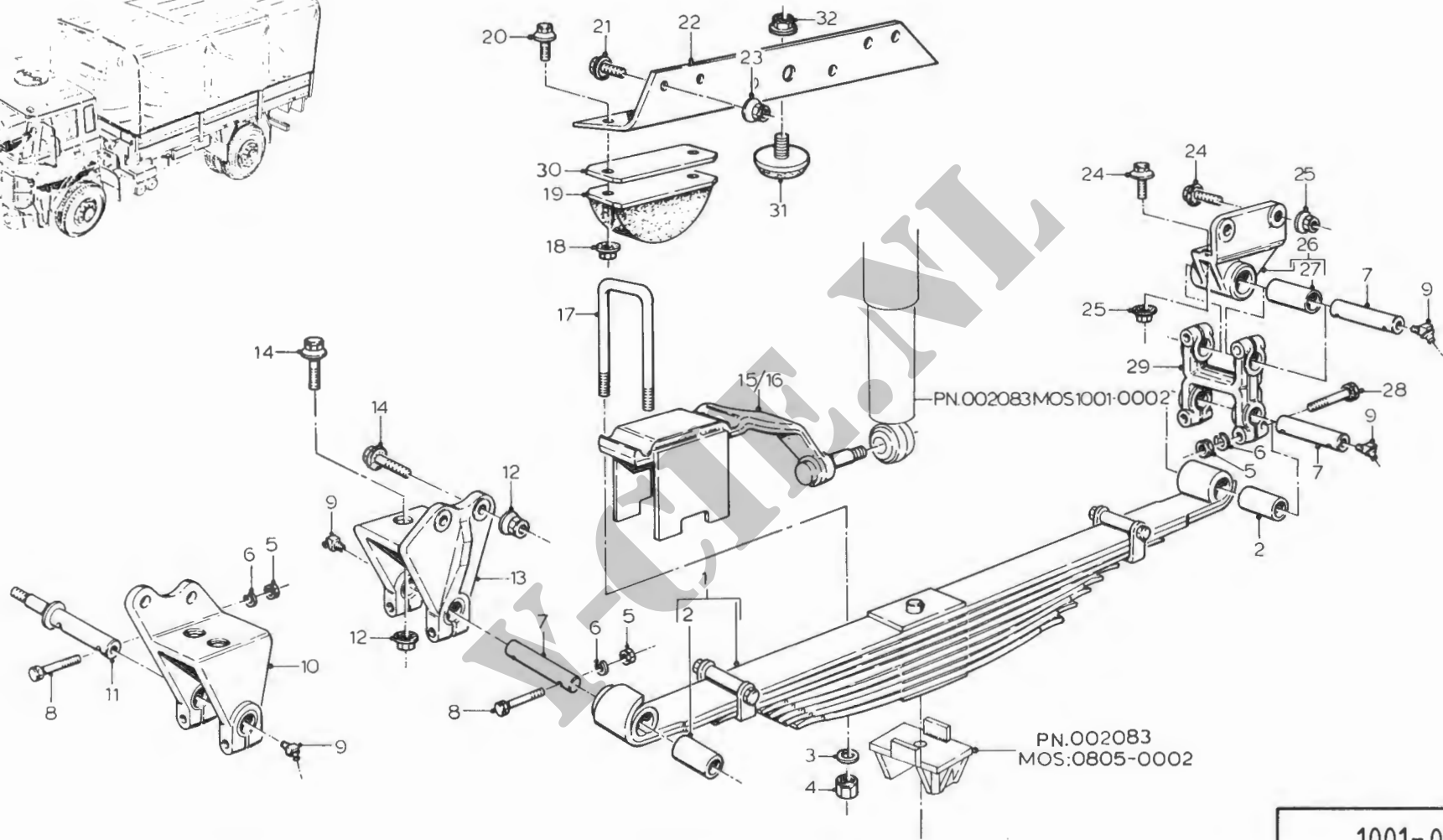
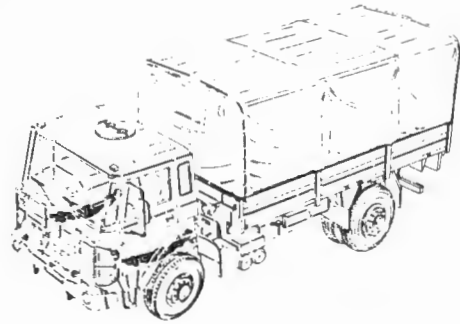

1001-0001

PN 002083

MOSNR 1001-0001

VOORVEER EN OPHANGING

DATUM: 890905

BLAD: 1

FIGNR	N MC	B	NSN	C	FCN	REFERENTIENUMMER (= FAN)	ARTIKELOMSCHRIJVING	TOELICHTING	AANT	ECH	OPMERKINGEN
3		B	5310-17-049-6788	0	H0001	0631425	ONDERLEGRING, VLAK		8	2	
4		B	5310-17-049-6836	4	H0001	0622041	MOER, ZESKANT		8	2	
9		B	4730-12-124-1174	0	H0001	0214740	NIPPEL, SMEER-		6	2	
					D8286	DIN71412-BM8X1					
15		B	2540-17-103-2460	5	H0001	0392894	STEUN SCHOKDEMPER	LINKS	1	2	
16		B	2540-17-103-2462	7	H0001	0392895	STEUN SCHOKDEMPER	RECHTS	1	2	
17		B	5306-17-049-7953	0	H0001	0330096	BOUT, U		4	2	
19		B	5340-14-358-4918	4	H0001	0012953	BUFFER, RUBBER		4	2	
					F0220	519356					
20		B	5305-17-103-0067	0	H0001	0268979	SCHROEF, GEASSEMBLE		8	2	
					D8286	DIN6921-M12X35X30X26,6X16X8.8					
21		B	5306-17-050-8005	8	H0001	0638043	BOUT, BORST		4	2	
23		B	5310-17-050-7984	9	H0001	0638050	MOER, KRAAG, ZESKANT		4	2	
31		B	0000-KL-042-9850	3	H0001	0076478	AANSLAG		2	2	
32		B	0000-KL-040-5698	7	H0001	0645165	MOER, FLENS-METR. GLA		2	2	

PN 002083

VOORVEER EN OPHANGING

MOSNR 1001-0001 BLAD:

1

66

-LAATSTE BLAD-

**YCHIE.ME**

**Y-CHE.ME**

PROJECTNUMMER: 002083  
MOSNUMMER : 1001-0002

### SCHOKBREKERS VOORAS

DATUM 871102  
BLAD 1 VAN 1 BLADEN

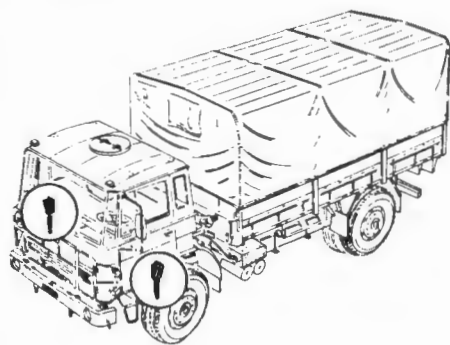

PN.002083  
MOS:1001-0001

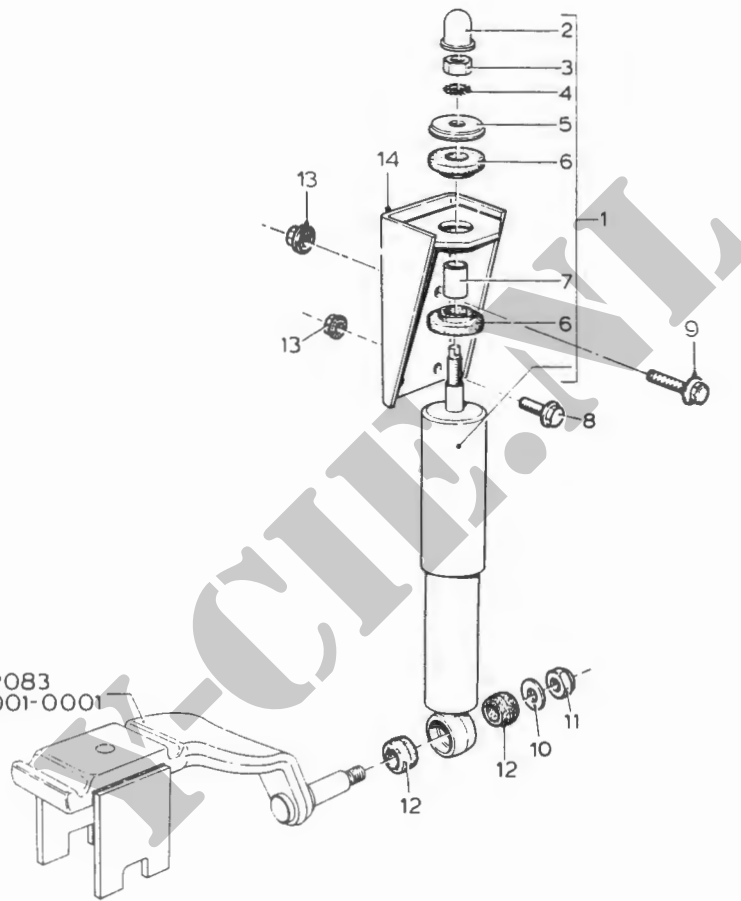

1001-0002

PN 002083

MOSNR 1001-0002

SCHOKBREKERS VOORAS

DATUM: 890905

BLAD: 1

FIGNR	N MC	B	NSN	C	FCN	REFERENTIENUMMER (= FAN)	ARTIKELOMSCHRIJVING TOELICHTING	AANT ECH	OPMERKINGEN
1		B	2540-17-103-2769	6	H0001	0392312	SCHOKDEMPER, TELESC	2 2	
					H0007	88-1481			
2		B	2530-17-049-8586	5	H0001	0574927	BESCHERMHOES, STOF E	1 2	
					H0007	1523240010			
3		B	5310-12-144-6177	6	H0001	0523873	MOER, ZESKANT	1001/0002/00001	
					D8286	DIN934-M16X1,5-8-A2P		4 2	
4		B	5310-12-131-4169	9	H0001	0251942	ONDERLEGRING, BORG-	1001/0001/00001	
					D8286	DIN6798-A16,5		4 2	
6		B	5365-17-049-9044	1	H0001	0580024	BUS, RUBBER	1001/0002/00001	
					H0007	1523310130		2 2	
7		B	2540-17-054-8999	5	H0001	0609984	BUS	1001/0002/00001	
					H0007	7052110080		1 2	
8		B	5306-17-050-8004	7	H0001	0638044	BOUT, MACHINE	1001/0002/00001	
9		B	5306-17-050-8005	8	H0001	0638043	BOUT, BORST	4 2	
10		B	5310-17-003-7284	0	H0001	0325291	ONDERLEGRING, VLAK	4 2	
11		B	5310-12-156-4984	2	H0001	0251278	MOER, ZESKANT	2 2	
					D8286	DIN934-M16-8-A2P		2 2	
12		B	5340-17-102-7264	1	H0001	0698669	TRILLINGSISOLATOR	8 2	
13		B	5310-17-050-7984	9	H0001	0638050	MOER, KRAAG, ZESKANT	8 2	

PN 002083

SCHOKBREKERS VOORAS

MOSNR 1001-0002 BLAD:

1

**YCHIE.ME**

**YCHIE.ME**

PROJECTNUMMER: 002083  
MOSNUMMER : 1002-0001

### ACHTERVEER EN OPHANGING

DATUM 871102  
BLAD 1 VAN 1 BLADEN

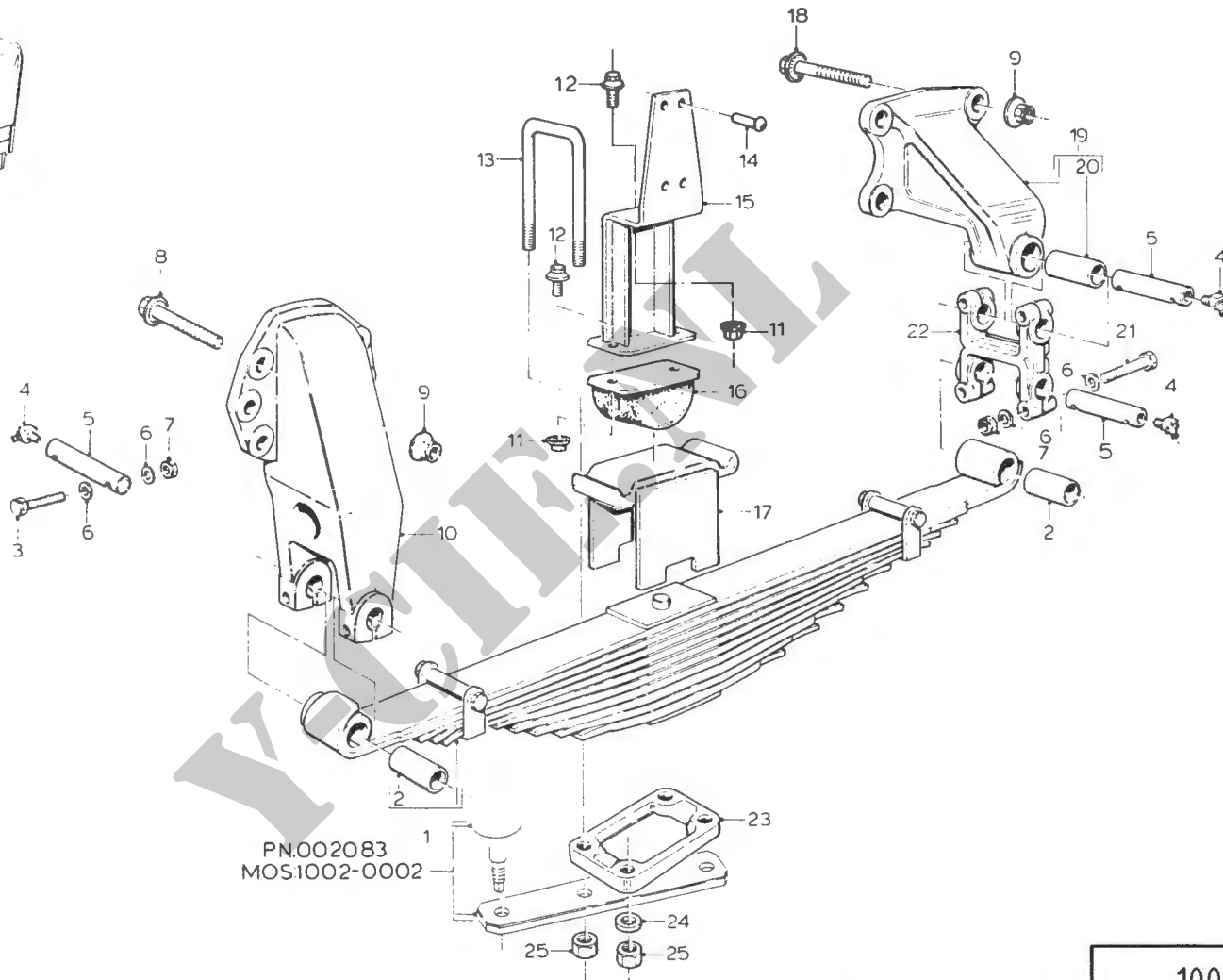
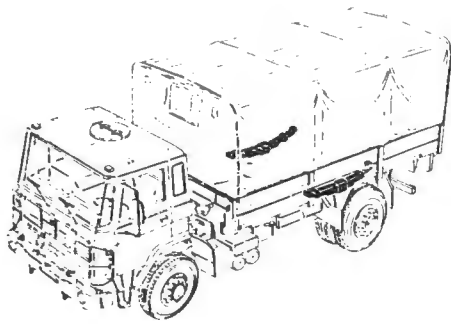

PN.002083  
MOS1002-0002

1002-0001

PN 002083

MOSNR 1002-0001

ACHTERVEER EN OPHANGING

DATUM: 890905

BLAD: 1

FIGNR	N	MC	B	NSN	C	FCN	REFERENTIENUMMER (= FAN)	ARTIKELOMSCHRIJVING TOELICHTING	AANT	ECH	OPMERKINGEN
4			B	4730-12-124-1174	0	H0001	0214740	NIPPEL, SMEER-	6	2	
							D8286 DIN71412-BM8X1				
13			B	5306-17-049-7953	0	H0001	0330096	BOUT, U	4	2	
16			B	5340-14-358-4918	4	H0001	0012953	BUFFER, RUBBER	2	2	
							F0220 519356				
24			B	5310-17-049-6788	0	H0001	0631425	ONDERLEGRING, VLAK	4	2	
25			B	5310-17-049-6836	4	H0001	0622041	MOER, ZESKANT	8	2	

V.CHE.ME

PN 002083

ACHTERVEER EN OPHANGING

MOSNR 1002-0001 BLAD: 1

68

-LAATSTE BLAD-

**YCHIE.ME**

**YCHIE.ME**

PROJECTNUMMER: 002083  
MOSNUMMER : 1002-0002

SCHOKBREKERS ACHTERAS

DATUM 871102  
BLAD 1 VAN 1 BLADEN

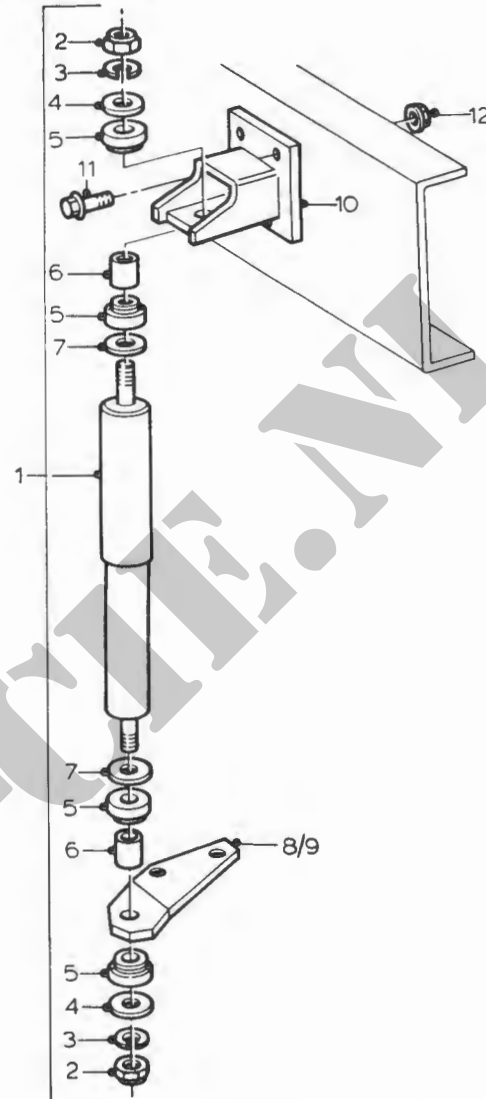
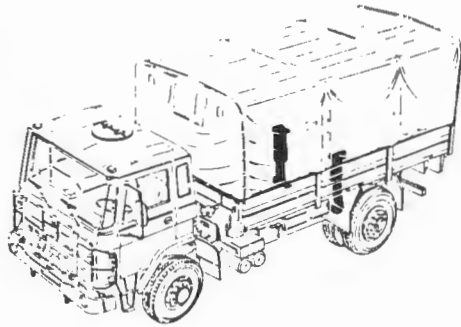

1002-0002

PN 002083

MOSNR 1002-0002

SCHOKBREKERS ACHTERAS

DATUM: 890905

BLAD: 1

FIGNR	N	MC	B	NSN	C	FCN	REFERENTIENUMMER (= FAN)	ARTIKELOMSCHRIJVING TOELICHTING	AANT	ECH	OPMERKINGEN
1			B	2540-17-052-9787	0	H0001	0616826	SCHOKDEMPER, TELESCO	2	2	
3			B	5310-12-167-1520	3	H0001	0251931	ONDERLEGRING, BORG-	2	2	
						D8286	DIN128-A14				
5			B	0000-KL-044-0799	7	H0001	0492112	SILENTBLOC	2	2	
						U0716	AAU 5043				
11			B	5306-17-051-5618	9	H0001	0638041	BOUT, MACHINE	8	2	
12			B	5310-17-050-9991	3	H0001	0638049	MOER, KRAAG, ZESKANT	8	2	

YCHIE.ME

PN 002083

SCHOKBREKERS ACHTERAS

MOSNR 1002-0002 BLAD:

1

**YCHIE.ME**

**YCHIE.ME**

PROJECTNUMMER: 002083  
MOSNUMMER : 1201-0001

# REMPEDAAL MET STANGEN

DATUM 871102  
BLAD 1 VAN 1 BLADEN

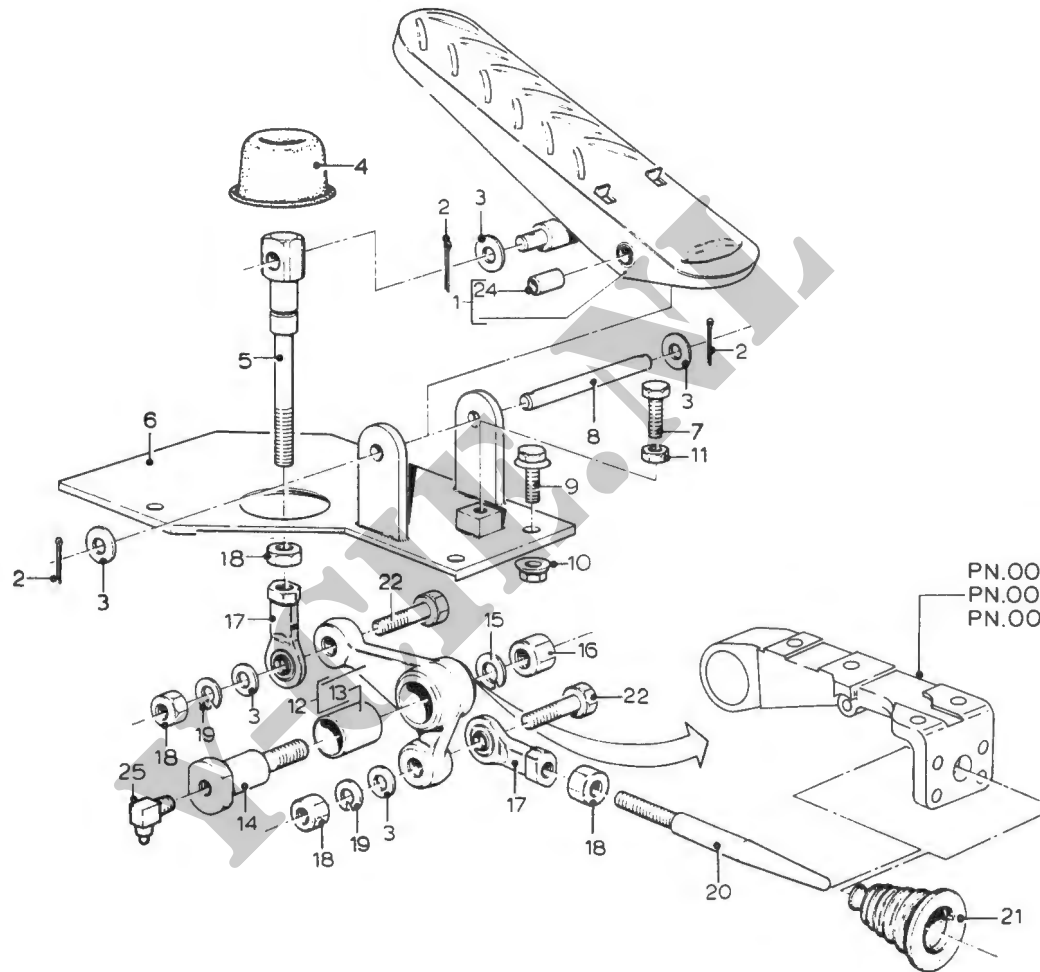
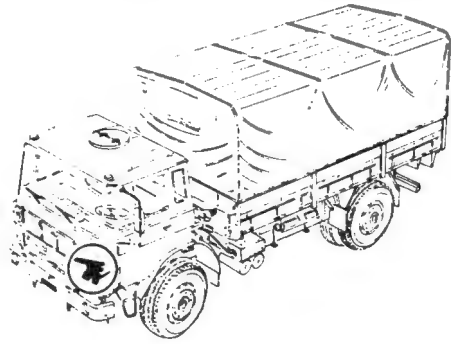

1201-0001

PN 002083

MOSNR 1201-0001

REMPEDAAL MET STANGEN

DATUM: 890905

BLAD: 1

FIGNR	N	MC	B	NSN	C	FCN	REFFRENTIENUMMER (= FAN)	ARTIKELOMSCHRIJVING TOELICHTING	AANT ECH	OPMERKINGEN
2			B	5315-12-181-9744	2	H0001	0251860	PEN, SPLIT	3	2
						D8286	DIN94-3,2X32-ST-ZNPHR10F			
3			B	5310-12-142-0481	6	H0001	0202817	ONDERLEGRING, VLAK	3	2
						D8286	DIN125-B10,5-ST-A3P			
25			B	4730-12-124-1176	1	H0001	0325071	NIPPEL, SMEER-	1	2
						D8286	DIN71412-CM8X1			

Y-CHE.ML

PN 002083

REMPEDAAL MET STANGEN

MOSNR 1201-0001 BLAD: 1

70

-LAATSTE BLAD-

**Y-CHE.ME**

**YCHIE.ME**

PROJECTNUMMER: 002083  
MOSNUMMER : 1201-0002

VOETREMKLEP

DATUM 871102  
BLAD 1 VAN 1 BLADEN

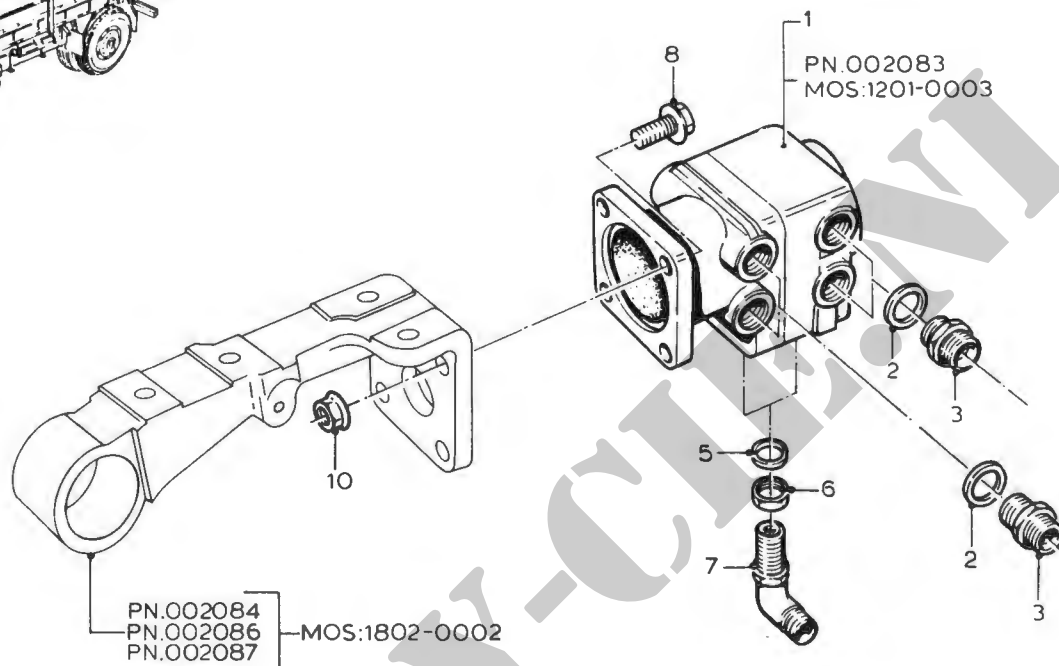
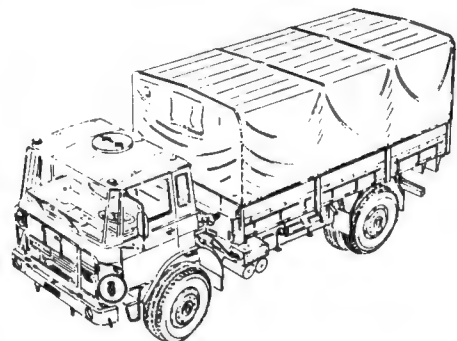

1201-0002

**Y-CHE.ME**

PN 002083

MOSNR 1201-0002

VOFTREMKLEP

DATUM: 890905

BLAD: 1

FIGNR	N	MC	B	NSN	C	FCN	REFERENTIENUMMER (= FAN)	ARTIKELOMSCHRIJVING TOELICHTING	AANT ECH	OPMERKINGEN
2			B	5330-17-050-2436	5	H0001	0260901	PAKINGRING MET HOU	4 2	
3			B	4730-17-102-9684	1	H0001	0369007	NIPPEL, PIJP	4 2	
5			B	5330-17-049-8488	6	H0001	0206786	PAKINGRING MET HOU	2 2	
						H0001	M12X1,5X16X2,5 DAFN.9105			
6			B	5310-12-144-2186	8	H0001	0226490	MOER,ZESKANT	2 2	
						D8286	DIN80705-M12X1,5-A2P			
7			B	4730-17-103-1543	1	H0001	0285447	KNIE, PIJP	2 2	

VOFTREMKLEP

PN 002083

VOETREMKLEP

MOSNR 1201-0002 BLAD: 1

-LAATSTE BLAD-

**Y-CHE.ME**

PROJECTNUMMER: 002083  
MOSNUMMER : 1201-0006

REMCILINDERS VOORAS

DATUM 871102  
BLAD 1 VAN 2 BLADEN

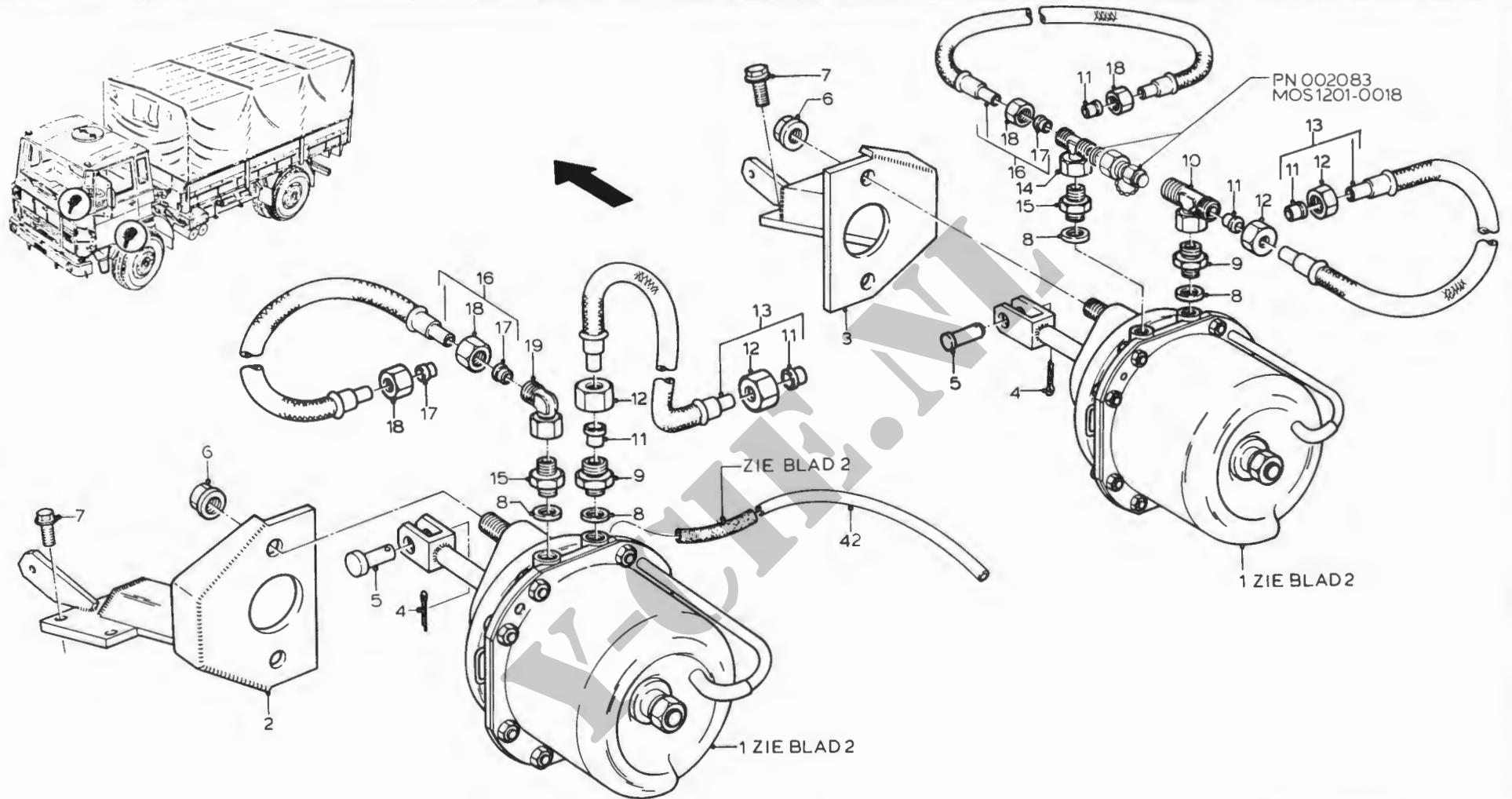

1201-0006

**Y-CHE.ME**

PROJECTNUMMER: 002083  
MOSNUMMER : 1201-0006

REMCILINDERS VOORAS (ONDERD.)

DATUM 871102  
BLAD 2 VAN 2 BLADEN

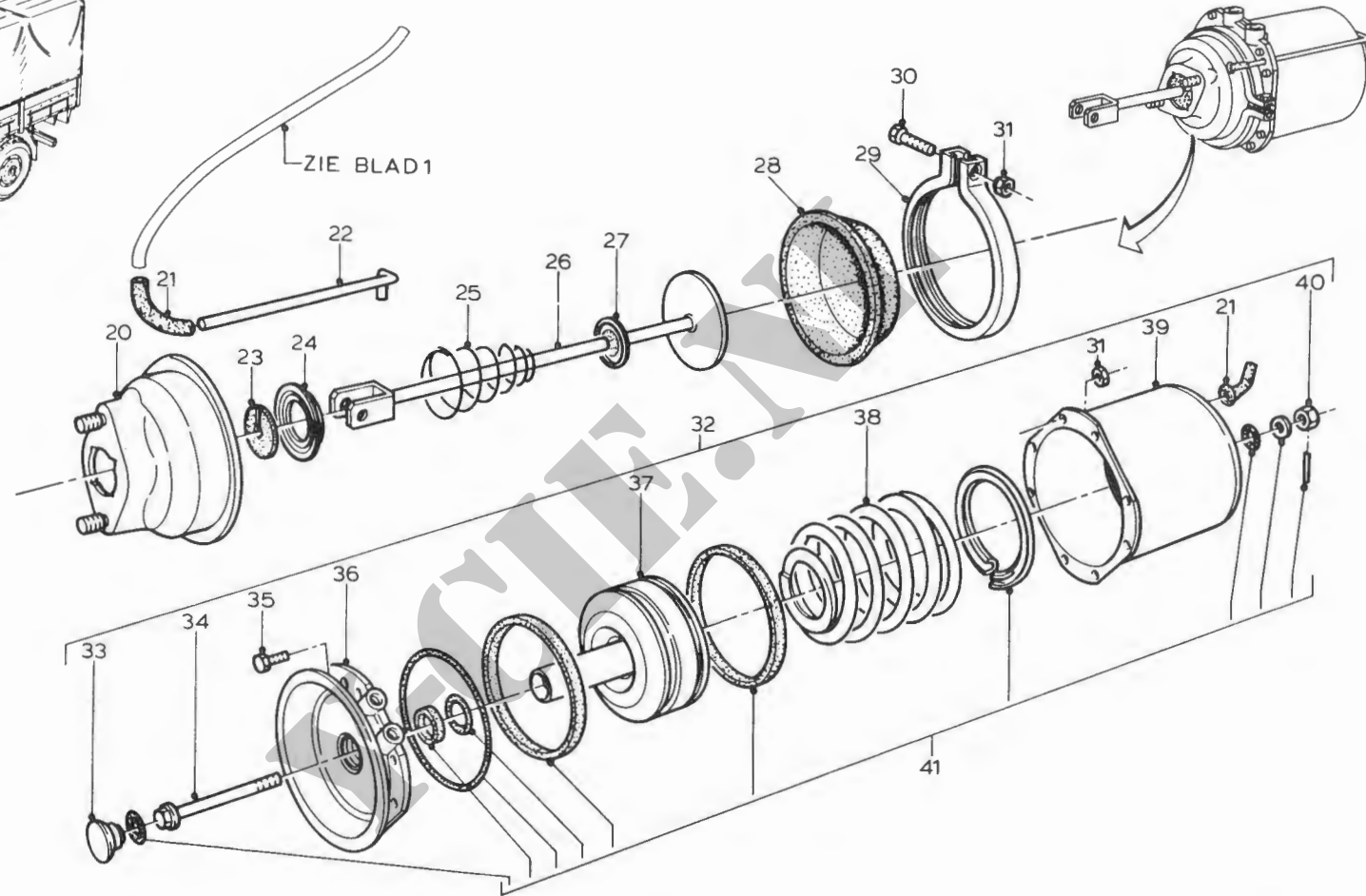
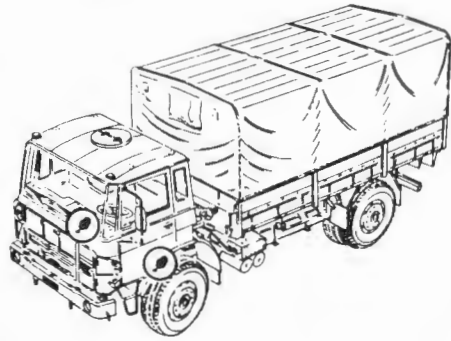

1201-0006

PN 002083

MOSNR 1201-0006

REMCILINDERS VOORAS (ONDERD.)

DATUM: 890905

BLAD: 1

FIGNR	N	MC	B	NSN	C	FCN	REFERENTIENUMMER (= FAN)	ARTIKELOMSCHRIJVING TOELICHTING	AANT ECH	OPMERKINGEN
8			B	5330-17-050-2436	5	H0001	0260901	PAKKINGRING MET HOU	4	2
9			B	4730-17-101-3977	2	H0001	0285456	VERLOOPSTUK, PYP	4	2
10			B	4730-17-102-9688	5	H0001	0369228	T-STUK, PIJP	1	2
11			B	4730-12-137-6457	4	H0001	0146141	HULS, INPERS-, PYPFIT	4	2
						D8286	DIN3861-L10-ST-A3P			
12			B	4730-12-123-4179	0	H0001	0146142	MOER, PYPKOPPELING	4	2
						D8286	DIN3870-AL10			
13			B	4720-17-054-8166	8	H0001	0629349	SLANGSAMENSTEL, GELA	2	2
14			B	4730-17-056-0406	5	H0001	0368997	T-STUK, PIJP	1	2
15			B	4730-17-103-4340	4	H0001	0285444	NIPPEL, PIJP	1	2
16			B	4720-17-054-7780	7	H0001	0656771	SLANGSAMENSTEL, GELA	1	2
17			B	4730-12-132-1953	5	D8286	DIN3861-L12-ST-A3P	HULS, INPERS-, PYPFIT	4	2
18			B	4730-12-132-1954	6	H0001	0238007	MOER, PYPKOPPELING	4	2
						D8286	DIN3870-AL12			
19			B	4730-17-101-5285	1	H0001	0285443	KNIE, PYP	1	2
21			B	4720-12-173-8428	9	H0001	0695756	SLANG, VOORGEVORMD	2	2
						D8096	8936103904			
42			B	4720-12-173-8649	0	H0001	0959033	PYP, NIET-METAAL	NB	2 MR
						D8286	DIN73378-PA11WSWLT-8X1			

1201/0006/00016

PN 002083

REMCILINDERS VOORAS (ONDERD.)

MOSNR 1201-0006 BLAD: 1

72

-LAATSTE BLAD-

**Y-CHE.ME**

Y-CHE.ME

PROJECTNUMMER: 002083

MOSNUMMER : 1201-0007

REMCILINDERS ACHTERAS

DATUM 871102

BLAD 1 VAN 1 BLADEN

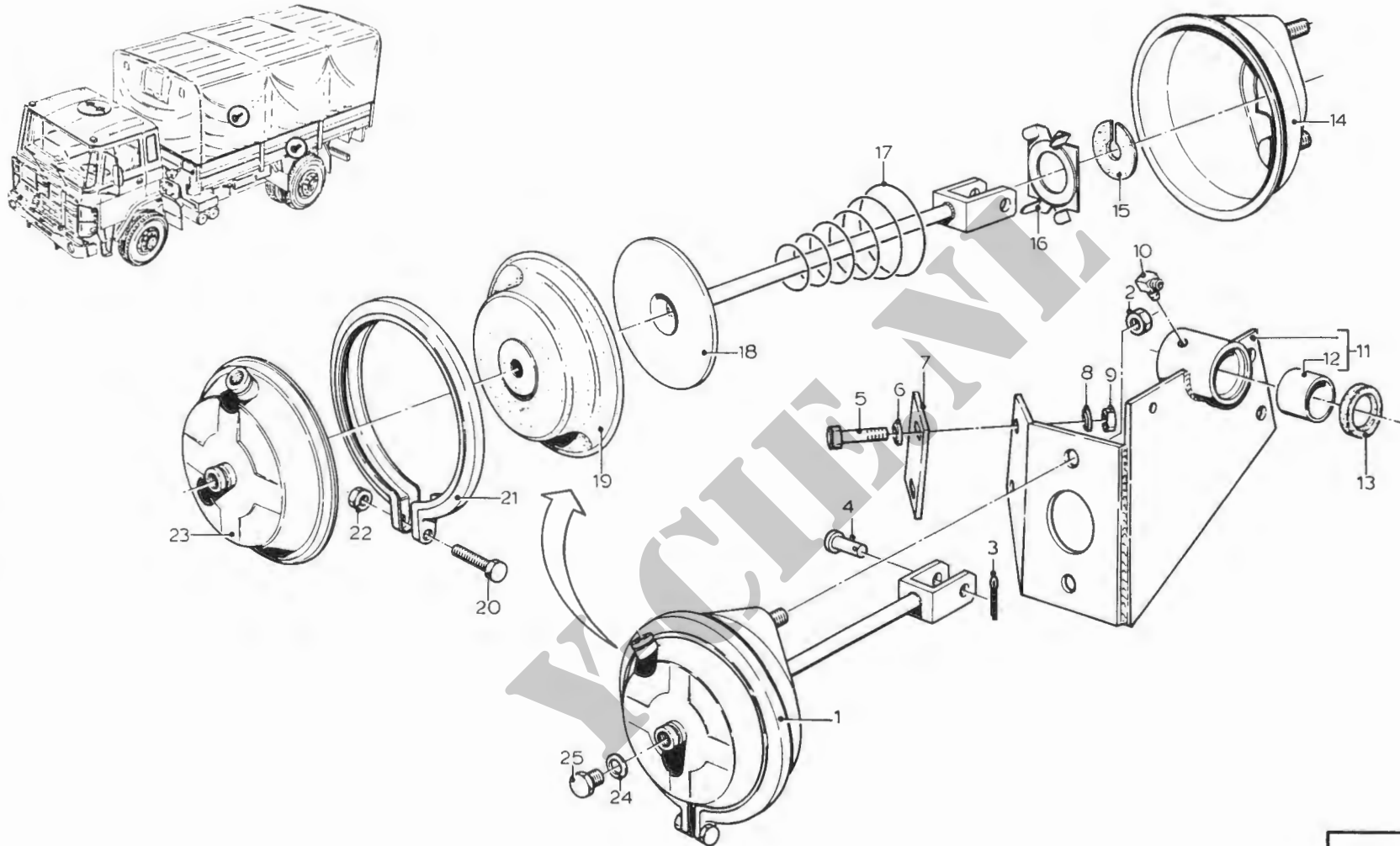

1201-0007

PN 002083

MOSNR 1201-0007

REMYLINDERS ACHTERAS

DATUM: 890905 BLAD: 1

FIGNR N MC B NSN C FCN REFERENTIENUMMER (= FAN)

ARTIKELOMSCHRIJVING TOELICHTING AANT ECH OPMERKINGEN

10 B 4730-17-007-1812 9 H0001 0119172

NIPPEL, SMEER- 2 2

Y-CHE.ML

PN 002083

REMYLINDERS ACHTERAS

MOSNR 1201-0007 BLAD: 1

73

-LAATSTE BLAD-

**YCHIE.ME**

**YCHIE.ME**

PROJECTNUMMER: 002083  
MOSNUMMER : 1201-0008

DRUKREGELAAR

DATUM 871102  
BLAD 1 VAN 1 BLADEN

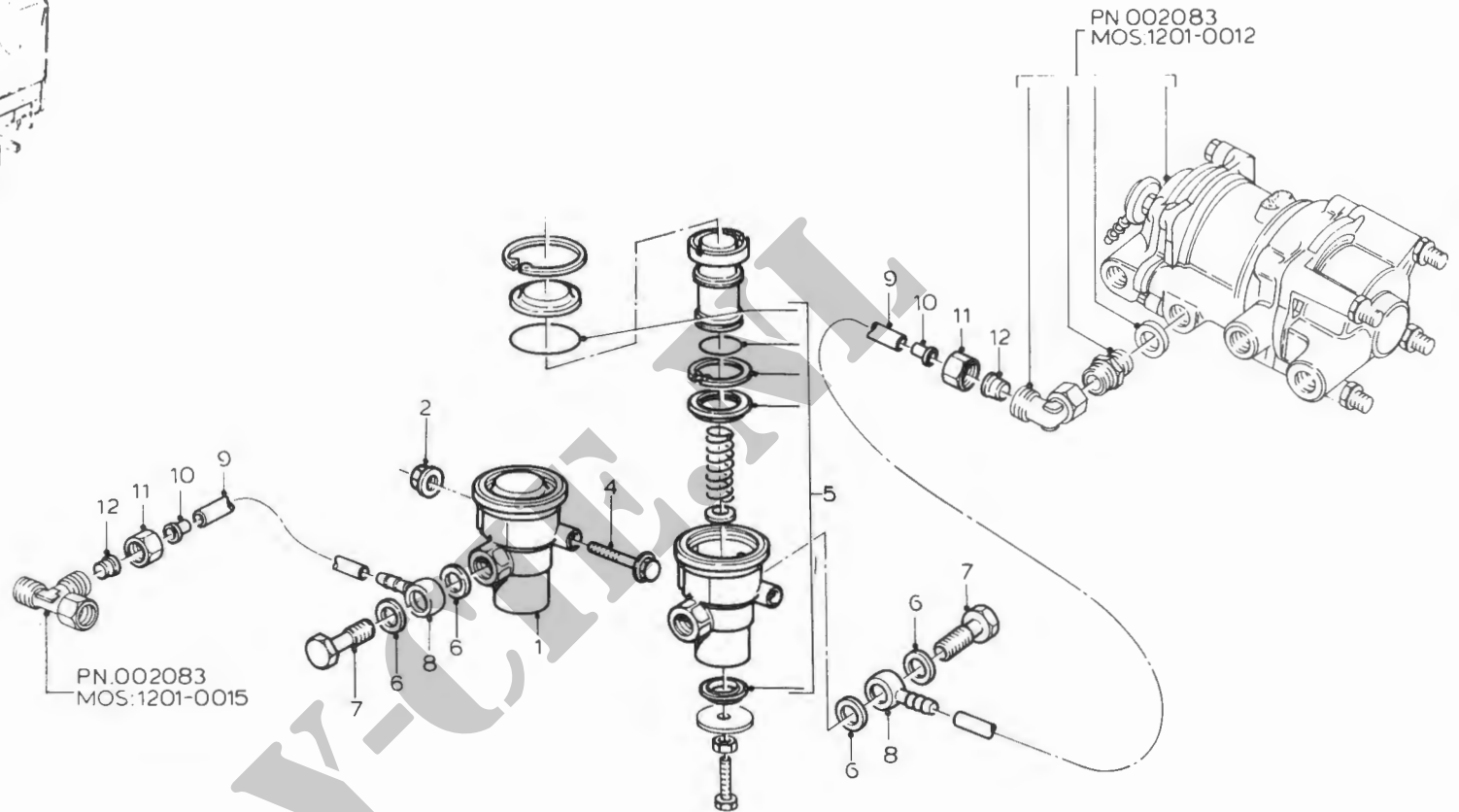
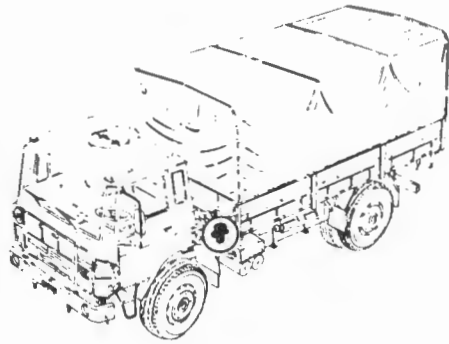

NIET GENUMMERDE DELEN NIET LOS LEVERBAAR

1201-0008

PN 002083

MOSNR 1201-0008

DRUKREGELAAR

DATUM: 890905 BLAD: 1

FIGNR	N	MC	B	NSN	C	FCN	REFERENTIENUMMER (= FAN)	ARTIKELOMSCHRIJVING TOELICHTING	AANT ECH	OPMERKINGEN
6			B	5330-12-156-4525	5	H0001	0322364	GASKET	2 2	
						D8286	DIN7603-A16X22-CU			
7			B	0000-KI-041-0631	1	H0001	0309114	BOUT, BANJO-	1 2	
						D8286	DIN7623-CXM16X1,5X11XA			
8			B	4730-17-103-3908	1	H0001	0665013	AANSLUITSTUK, MEERV	2 2	
9			B	4710-12-198-6974	0	H0001	0799008	BUIS, KUNSTSTOF	NB 2	MR
						D8286	DIN73378-PA11WSWT-12X1,5			
10			B	4730-12-174-0670	7	H0001	0649254	HULS, TROMPETVORMIG,	2 2	
11			B	4730-12-132-1954	6	H0001	0238007	MOER, PYPKOPPELING	2 2	
						D8286	DIN3870-AL12			
12			B	4730-12-132-1953	5	H0001	0633246	HULS, INPERS-, PYPFIT	2 2	
						D8286	DIN3861-L12-ST-A3P			

PN 002083

DRUKREGELAAR

MOSNR 1201-0008 BLAD: 1

**Y-CHE.ME**

**YCHIE.ME**

PROJECTNUMMER: 002083

MOSNUMMER : 1201-0009

LUCHTDROGER

DATUM 871102

BLAD 1 VAN 1 BLADEN

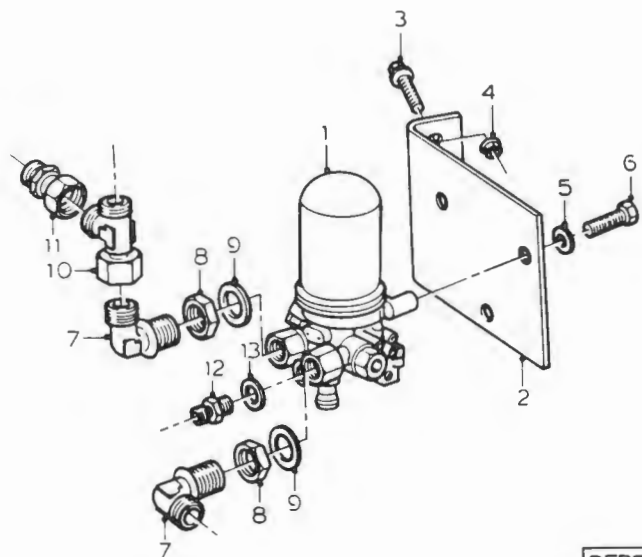
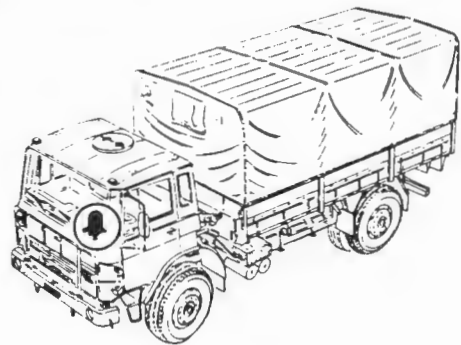

41  
REPERATIESET.  
ONDERDELEN GEMERKT MET ▲

NIET GENUMMERDE DELEN NIET LOS LEVERBAAR

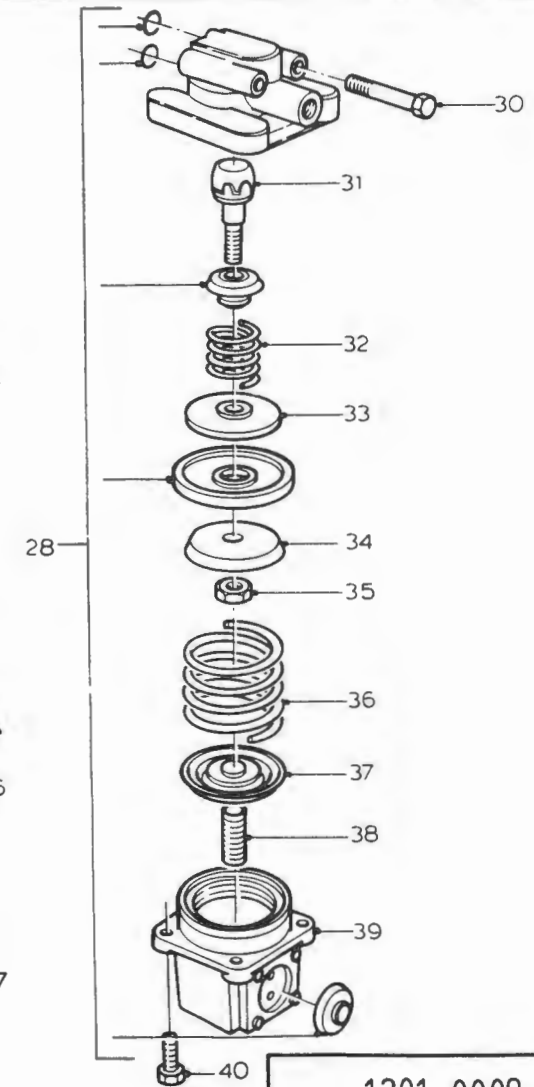
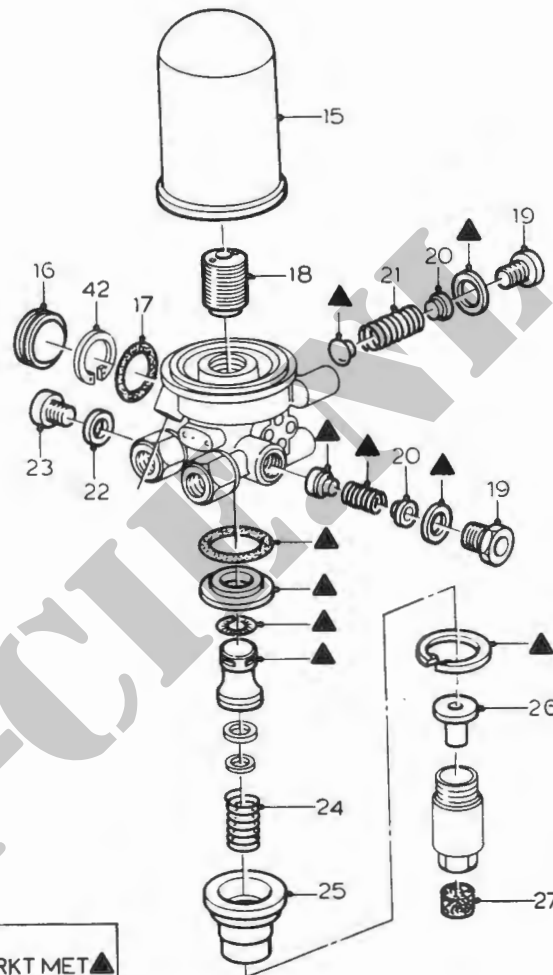

1201-0009

PN 002083

MOSNR 1201-0009

LUCHTDROGER

DATUM: 890905

BLAD: 1

FIGNR	N	MC	B	NSN	C	FCN	REFERENTIENUMMER (= FAN)	ARTIKELOMSCHRIJVING TOELICHTING	AANT	ECH	OPMERKINGEN
1			B	2530-12-316-8437	7	H0001	0220340	LUCHTDROGER	1	2	R
						D8015	0484460107				
3			B	0000-KL-041-0633	3	H0001	0278863	BOUT, FLENS-	2	2	
						D8286	DIN6921-M10X25X8.8				
4			B	5310-12-312-2850	4	H0001	0272657	MOER, KRAAG, ZESKANT	2	2	
						D8286	DIN6923-M10-8-A2P				
5			B	5310-12-162-2132	5	H0001	0251930	ONDERLEGRING, BORG-	3	2	
						D8286	DIN128-A12				
6			B	0000-KL-041-0634	4	H0001	0505973	BOUT, TAP-	3	2	
						D8286	DIN961-M12X1,5X25				
7			B	4730-17-103-2510	0	H0001	0368986	KNIE, PYP	2	2	
8			B	5310-12-144-4041	4	H0001	0226492	MOER, ZESKANT	2	2	
						D8286	DIN74305-M22X1,5-A2P				
9			B	5330-17-015-9817	3	H0001	0147120	PAKKING MET HOUDER	2	2	
						H0001	M22X1,5X27,0X2,5DAFN9105				
10			B	4730-17-101-6255	3	H0001	0369002	T-STUK, PIJP	1	2	
11			B	0000-KL-041-0636	6	H0001	0369009	KLEMK. MET EPOXYHAR	1	2	
12			B	4730-17-103-1545	3	H0001	0285442	NIPPEL, PIJP	1	2	
13			B	5330-17-049-8488	6	H0001	0206786	PAKKINGRING MET HOU	1	2	
						H0001	0206786				
15			B	4440-12-317-3056	6	D8015	1487434901	ELEMENT LUCHTFILTER	1	2	
27			B	2940-12-317-5293	0	D8015	1483200004	FILTERELEMENT, VLOEI	1	2	
30			B	5305-12-142-0191	2	H0001	0251478	SCHROEF, ZESKANTE KO	2	2	
						D8286	DIN931-M6X50-8,8-A2P				

PN 002083

LUCHTDROGER

MOSNR 1201-0009 BLAD: 1

**KCH.ME**

Y-CHE.ME

PROJECTNUMMER: 002083

MOSNUMMER : 1201-0010

# RELAISVENTIEL

DATUM 871102

BLAD 1 VAN 1 BLADEN

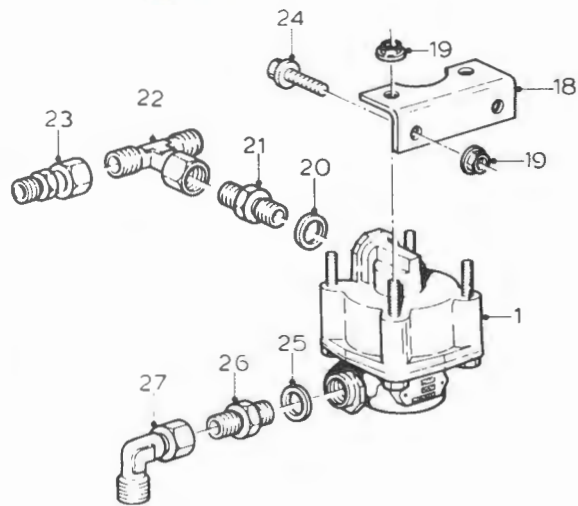
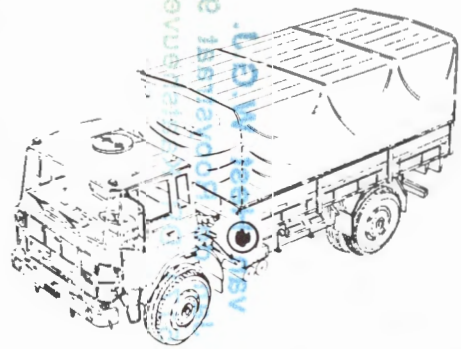

REPARATIESET  
ONDERDELEN GEMERKT MET ▲

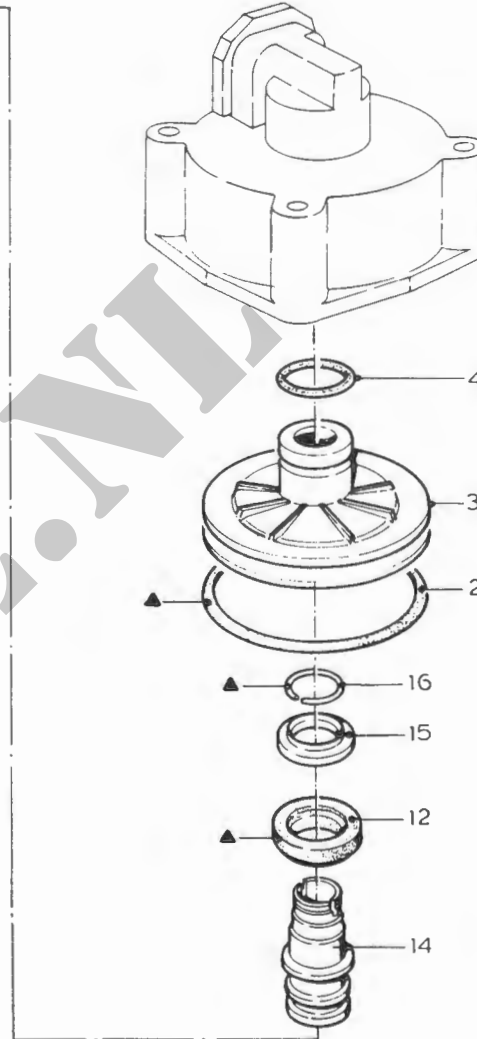
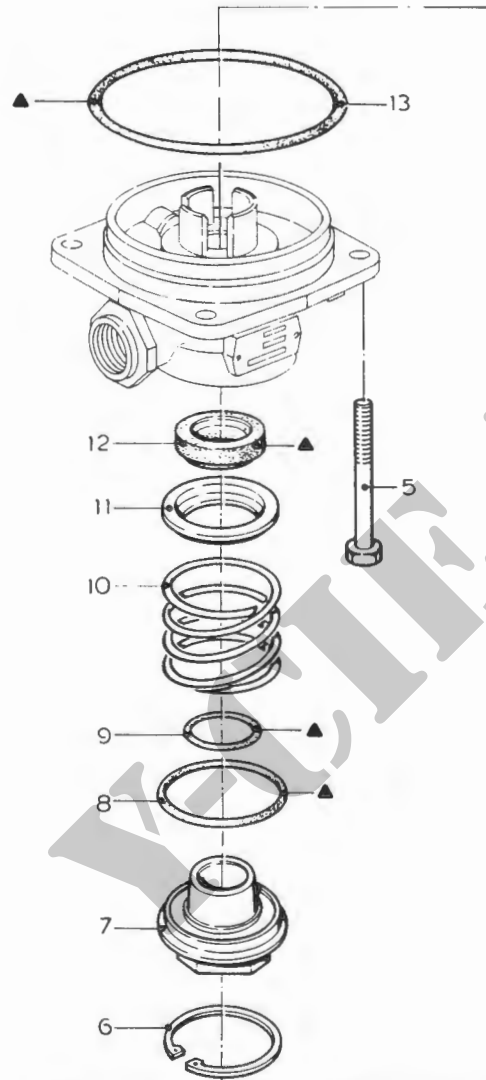

1201-0010

PN 002083

MOSNR 1201-0010

RELAISVENTIEL

DATUM: 890905 BLAD: 1

FIGNR	N MC	B	NSN	C	FCN	REFERENTIENUMMER (= FAN)	ARTIKELOMSCHRIJVING TOELICHTING	AANT ECH	OPMERKINGEN
20		B	5330-17-015-9817	3	H0001	0147120	PAKKING MET HOUDER	1	2
					H0001	M22X1,5X27X2,5 DAFN. 9105			
21		B	4730-17-102-9689	6	H0001	0369027	AANPASSTUK, REC	1	2
22		B	4730-17-103-3912	5	H0001	0368998	T-STUK, PIJP	1	2
23		B	0000-KL-041-0636	6	H0001	0369009	KLEMK. MET EPOXYHAR	1	2
25		B	5330-17-050-2436	5	H0001	0260901	PAKKINGRING MET HOU	1	2
26		B	4730-17-103-4340	4	H0001	0285444	NIPPEL, PIJP	1	2
27		B	4730-17-101-5285	1	H0001	0285443	KNIE, PYP	1	2

YCHIE.ML

PN 002083

RELAISVENTIEL

MOSNR 1201-0010 BLAD: 1

**Y-CHE.ME**

**YCHIE.ME**

PROJECTNUMMER: 002083

MOSNUMMER : 1201-0012

REACTIEVENTIEL

DATUM 871102

BLAD 1 VAN 1 BLADEN

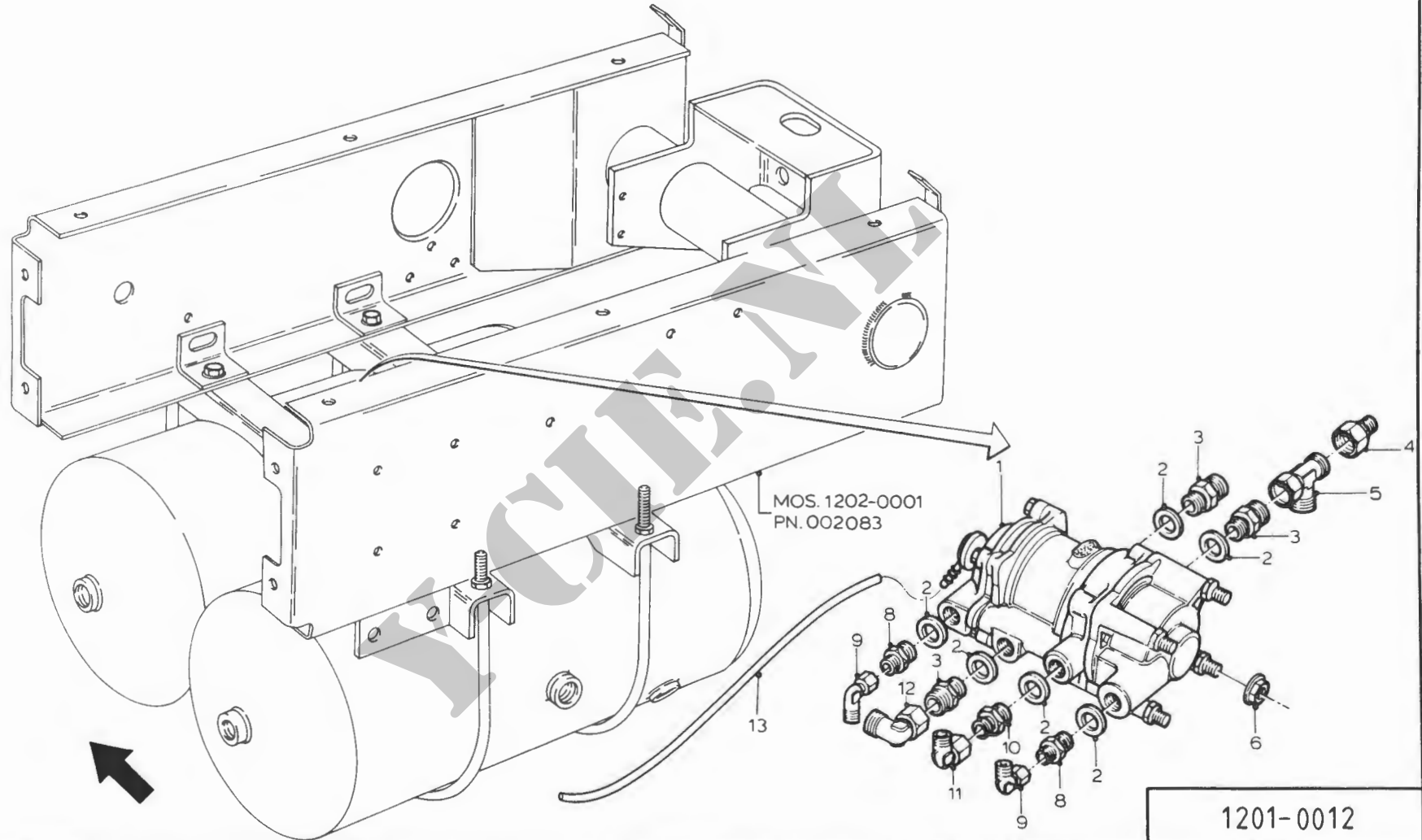

**YCHIE.ME**

PN 002083

MOSNR 1201-0012

REACTIEVENTIEL

DATUM: 890905 BLAD: 1

FIGNR	N	MC	B	NSN	C	FCN	REFERENTIENUMMER (= FAN)	ARTIKELOMSCHRIJVING TOELICHTING	AANT ECH	OPMERKINGEN	
2			B	5330-17-050-2436	5	H0001	0260901	PAKKINGRING MET HOU	6	2	
3			B	4730-17-101-3977	2	H0001	0285456	VERLOOPSTUK, PYP	3	2	
4			B	0000-KL-041-0670	7	H0001	0285446	KLEMK. MET EPOXYHAR	1	2	
5			B	4730-17-103-3910	3	H0001	0285450	KNIE, PIJP	1	2	
6			B	5310-17-915-1028	1	H0001	0268985	MOER, FLENS-	4	2	
						D8286	DIN. 6923 M8X17,9X8X13X8				
8			B	0000-KL-041-0672	9	H0001	0285457	KLEMK. MET EPOXYHAR	2	2	
9			B	4730-17-101-5458	9	H0001	0285448	KNIE, PYP	2	2	
10			B	4730-17-102-9684	1	H0001	0369007	NIPPEL, PIJP	1	2	
11			B	4730-17-103-2509	0	H0001	0368985	KNIE, PYP	1	2	
12			B	4730-17-101-5455	6	H0001	0285449	KNIE, PYP	1	2	
13			B	4720-17-049-7595	4	H0001	0799017	SLANG, NIET-METAAL	NB 2		MR

KCHIE.ML

PN 002083

REACTIEVENTIEL

MOSNR 1201-0012 BLAD: 1

77

-LAATSTE BLAD-

**YCHIE.ME**

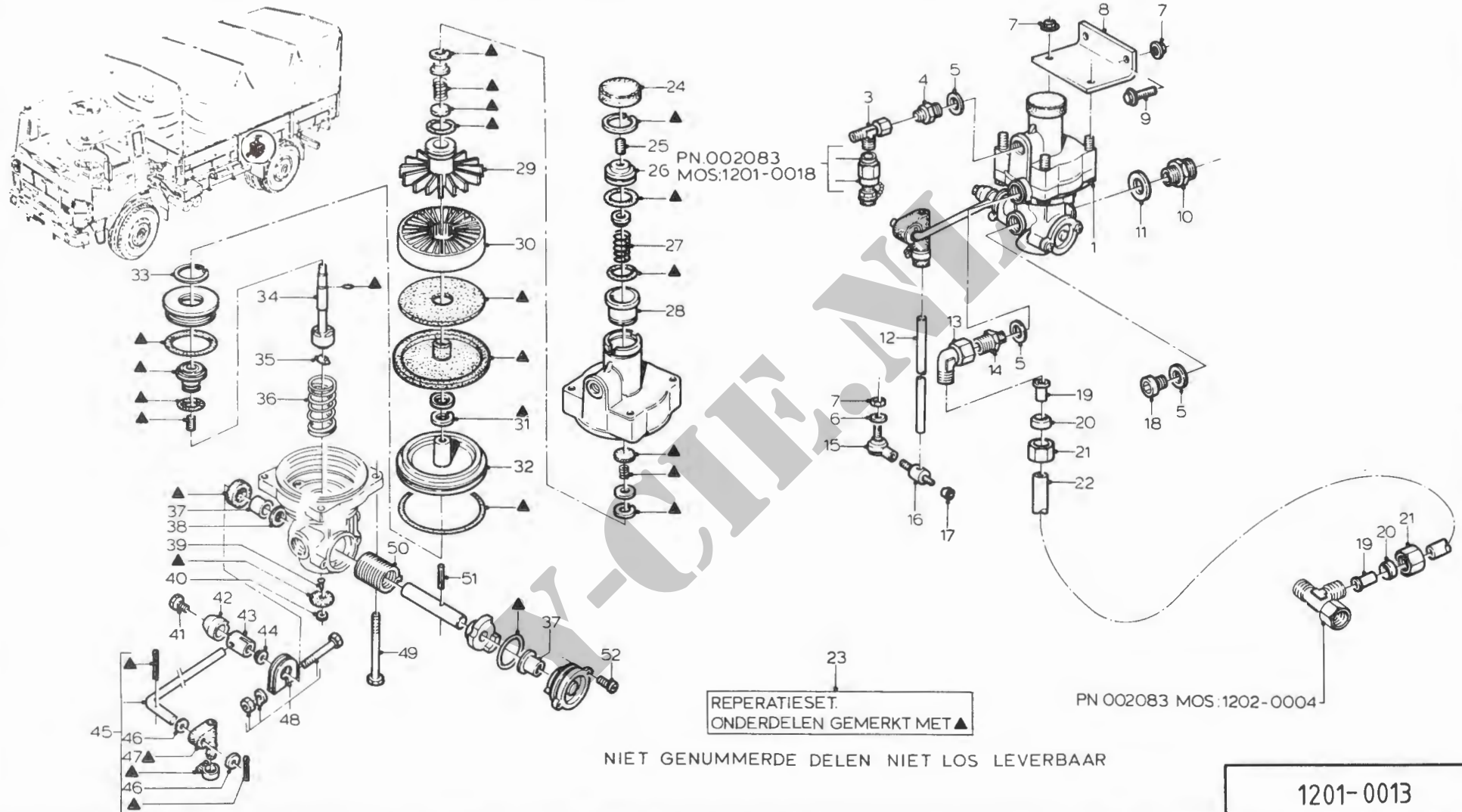

PN 002083

MOSNR 1201-0013

LASTAFH.REMREGELING

DATUM: 890905

BLAD: 1

FIGNR	N MC	B	NSN	C	FCN	REFERENTIENUMMER (= FAN)	ARTIKELOMSCHRIJVING TOELICHTING	AANT ECH	OPMERKINGEN
3		B	4730-17-103-3915	8	H0001	0369003	KNIE, PIJP	1 2	
4		B	4730-17-102-9684	1	H0001	0369007	NIPPEL, PIJP	1 2	
5		B	5330-17-050-2436	5	H0001	0260901	PAKKINGRING MET HOU	3 2	
10		B	0000-KL-041-0676	2	H0001	0373814	KLEMK. MET EPOXYHAR	1 2	
11		B	5330-17-015-9817	3	H0001	0147120	PAKKING MET HOUDER	1 2	
					H0001	M22X1,5X27,0X2,5DAFN9105			
13		B	4730-17-101-6405	0	H0001	0368984	KNIE, PYP	1 2	
14		B	0000-KL-041-0678	4	H0001	0285455	KLEMK. MET EPOXYHAR	1 2	
19		B	5320-17-052-7399	9	H0001	0624111	KLINKNAGEL, BUISVORM	2 2	
			4730-12-172-5861						DIT NSN IS VERVALLEN BIJ BESTELLING
20		B	4730-12-131-3696	9	H0001	0624114	HULS, INPERS-, PYPFIT	2 2	
					D8286	DIN3861-L15-ST-A3P			
21		B	4730-12-132-1910	6	H0001	0719243	MOER, PYPKOPPELING	2 2	
					D8286	DIN3870-AL15			
22		B	4720-17-051-0795	4	H0001	0799006	SLANG, NIET-METAAL	NB 2	MR

PN 002083

LASTAFH.REMREGELING

MOSNR 1201-0013 BLAD:

1

78

-LAATSTE BLAD-

**Y-CHE.ME**

**KCH.ME**

PROJECTNUMMER: 002083  
MOSNUMMER : 1201-0014

### 4-KRINGS VEILIGH. VENTIEL

DATUM 871102  
BLAD 1 VAN 1 BLADEN

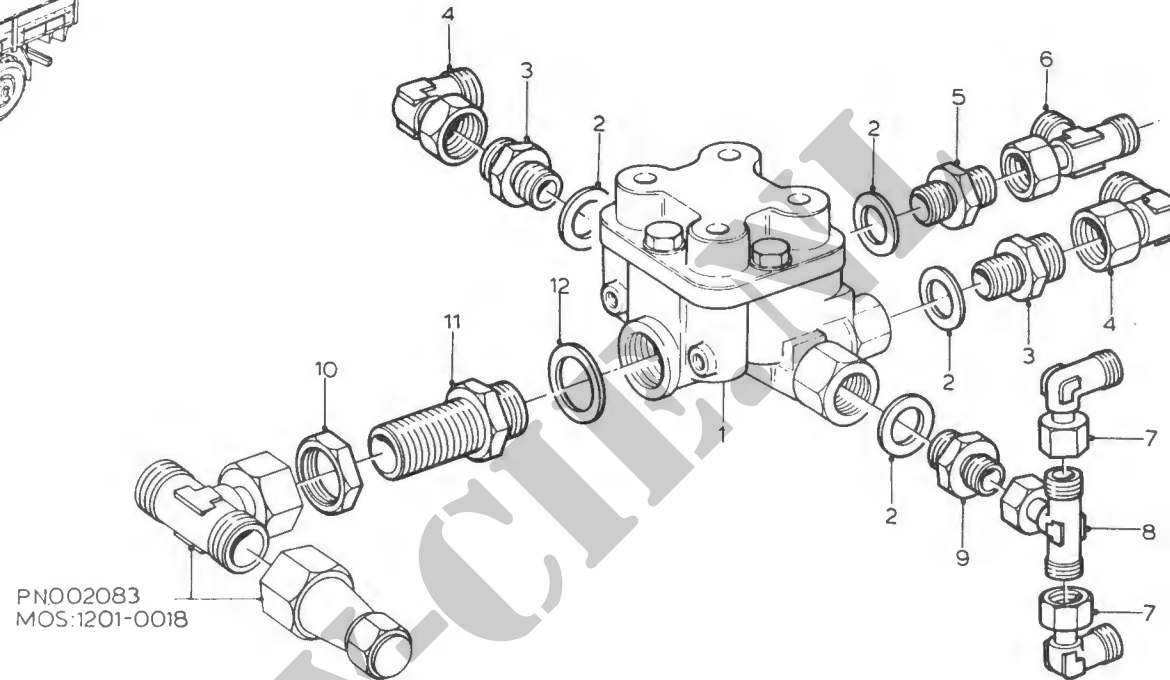
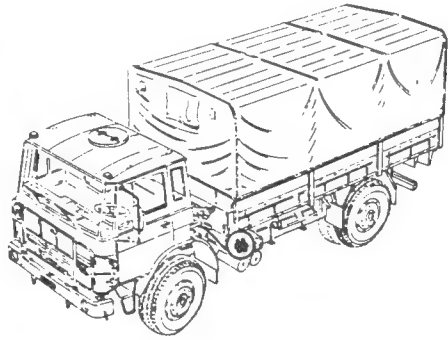

1201-0014

PN 002083

MOSNR 1201-0014

4-KRINGS VEILIGH.VENTIEL

DATUM: 890905 BLAD: 1

FIGNR	N MC	B	NSN	C	FCN	REFERENTIENUMMER (= FAN)	ARTIKELOMSCHRIJVING TOELICHTING	AANT ECH	OPMERKINGEN
2		B	5330-17-050-2436	5	H0001	0260901	PAKKINGRING MET HOU	4 2	
3		B	4730-17-101-3977	2	H0001	0285456	VERLOOPSTUK, PYP	2 2	
4		B	4730-17-101-5455	6	H0001	0285449	KNIE, PYP	2 2	
5		B	4730-17-103-4340	4	H0001	0285444	NIPPEL, PIJP	1 2	
6		B	4730-17-102-9691	8	H0001	0285445	T-STUK, PIJP	1 2	
7		B	4730-17-103-2509	0	H0001	0368985	KNIE, PYP	2 2	
8		B	4730-17-103-3909	2	H0001	0368999	T-STUK, PIJP	1 2	
9		B	4730-17-102-9684	1	H0001	0369007	NIPPEL, PIJP	1 2	
10		B	5310-12-144-4041	4	H0001	0226492	MOER, ZESKANT	1 2	
					D8286	DIN74305-M22X1,5-A2P			
11		B	4730-17-103-2511	1	H0001	0368992	NIPPEL, PYP	1 2	
12		B	5330-17-015-9817	3	H0001	0147120	PAKKING MET HOUDER	1 2	
					H0001	M22X1,5X27,0X2,5DAFN9105			

PN 002083

4-KRINGS VEILIGH.VENTIEL

MOSNR 1201-0014 BLAD: 1

79

-LAATSTE BLAD-

**Y-CHE.ME**

Y-CHE.ME

PROJECTNUMMER: 002083  
MOSNUMMER : 1201-0015

TERUGSLAGKLEP

DATUM 871102  
BLAD 1 VAN 1 BLADEN

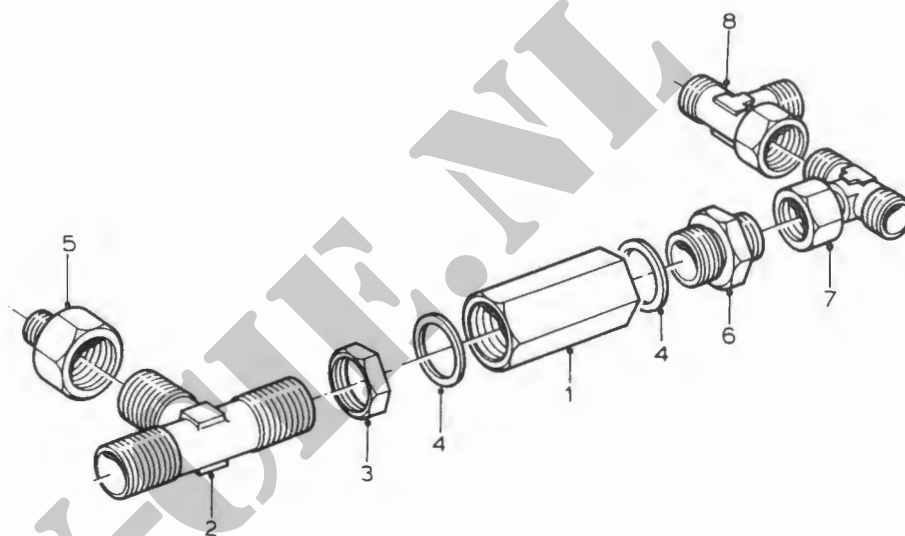
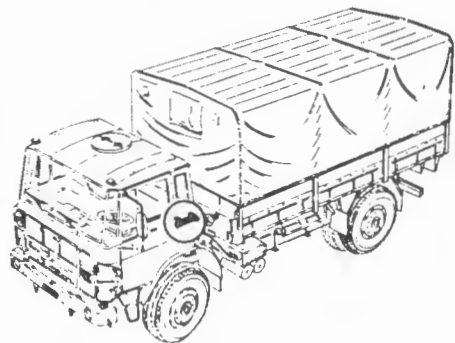

1201-0015

PN 002083

MOSNR 1201-0015

TERUGSLAGKLEP

DATUM: 890905 BLAD: 1

FIGNR	N	MC	B	NSN	C	FCN	REFERENTIENUMMER (= FAN)	ARTIKELOMSCHRIJVING TOELICHTING	AANT	ECH	OPMERKINGEN
2			B	4730-17-102-9687	4	H0001	0368996	T-STUK, PIJP	1	2	
3			B	5310-12-144-4041	4	H0001	0226492	MOER, ZESKANT	2	2	
						D8286	DIN74305-M22X1,5-A2P				
4			B	5330-17-015-9817	3	H0001	0147120	PAKKING MET HOUDER	2	2	
						H0001	M22X1,5X27,0X2,5DAFN9105				
5			B	0000-KL-041-0687	2	H0001	0369010	KLEMK. MET EPOXYHAR	1	2	
6			B	0000-KL-041-0688	3	H0001	0369226	KLEMK. MET EPOXYHAR	1	2	
7			B	4730-17-102-9688	5	H0001	0369228	T-STUK, PIJP	1	2	
8			B	4730-17-103-3910	3	H0001	0285450	KNIE, PIJP	1	2	

V.CHE.M.B.

PN 002083

TERUGSLAGKLEP

MOSNR 1201-0015 BLAD: 1

**Y-CHE.ME**

**YCHIE.ME**

PROJECTNUMMER: 002083  
MOSNUMMER : 1201-0018

MEETAANSLUITING

DATUM 871102  
BLAD 1 VAN 1 BLADEN

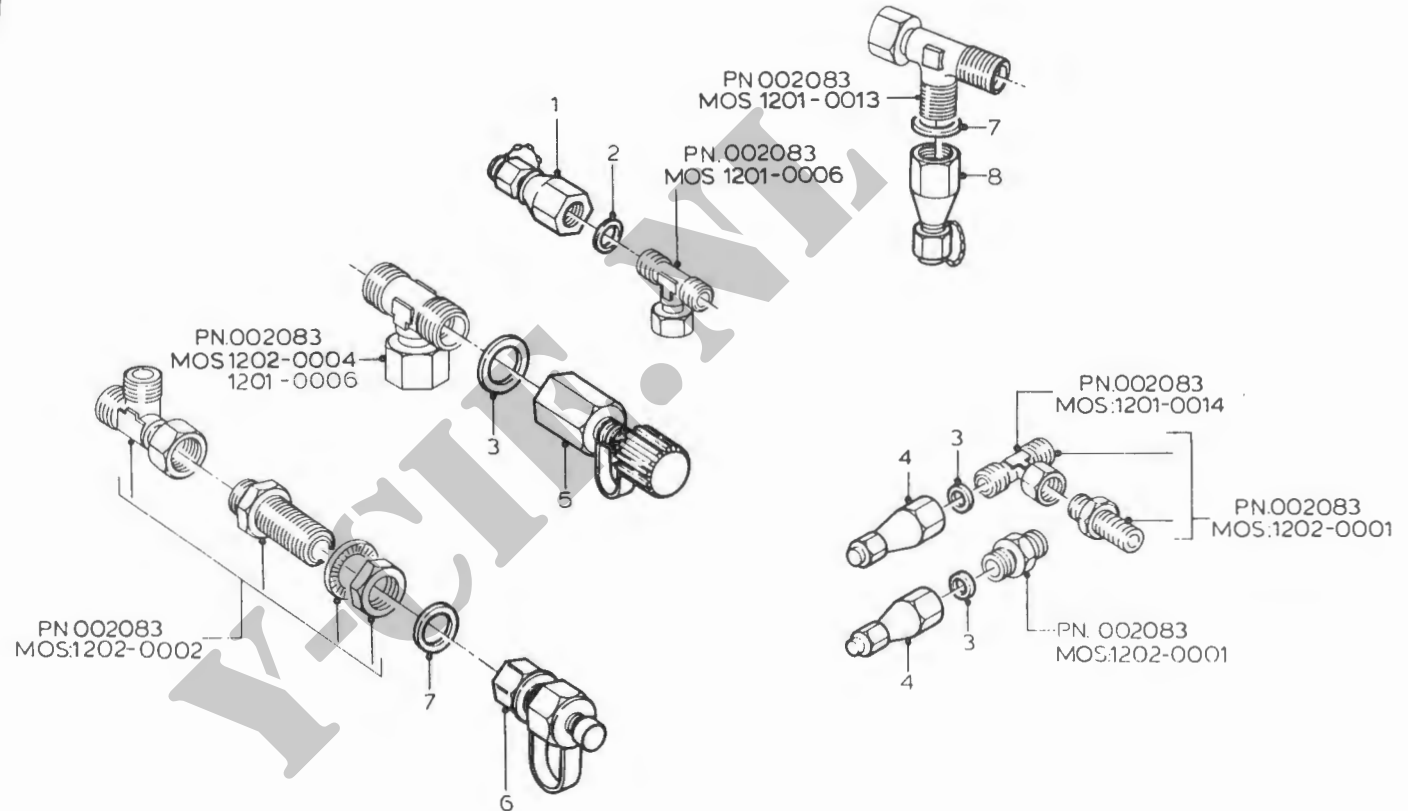
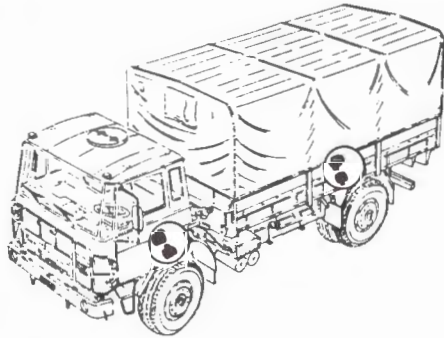

1201-0018

PN 002083

MOSNR 1201-0018

MEETAANSLUITING

DATUM: 890905 BLAD: 1

FIGNR	N MC	B	NSN	C	FCN	REFERENTIENUMMER (= FAN)	ARTIKELOMSCHRIJVING	TOELICHTING	AANT	ECH	OPMERKINGEN
1		B	4730-12-191-4724	8	D9596	268325	AANSLUITNIPPEL		1	2	
2		B	5365-17-024-2634	1	H0001	0215523	AFSTANDSIUK, RING		1	2	
3		B	5330-12-156-4525	5	H0001	0322364	GASKET		3	2	
						D8286	DIN7603-A16X22-CU				
4		B	4730-12-312-3295	9	D9596	268345	TESTAANSLUITING		1	2	
5		B	4730-12-195-7652	3	H0001	0656778	VERSCHRAUBUNG, PRUEF		1	2	
6		B	4730-12-172-0571	5	H0001	0105042	VERSCHRAUBUNG, PRUEF		1	2	
7		B	5330-17-706-7593	0	H0001	0206784	PAKKINGRING		1	2	
						H0001	0206784				
8		B	0000-KL-041-0674	0	H0001	0393907	PROEFAANSLUITING		1	2	
						D9596	268315				

PN 002083

MEETAANSLUITING

MOSNR 1201-0018 BLAD: 1

81

-LAATSTE BLAD-

**Y-CHE.ME**

**Y-CHE.ME**

PROJECTNUMMER: 002083  
MOSNUMMER : 1202-0001

LUCHTKETELS

DATUM 871102  
BLAD 1 VAN 2 BLADEN

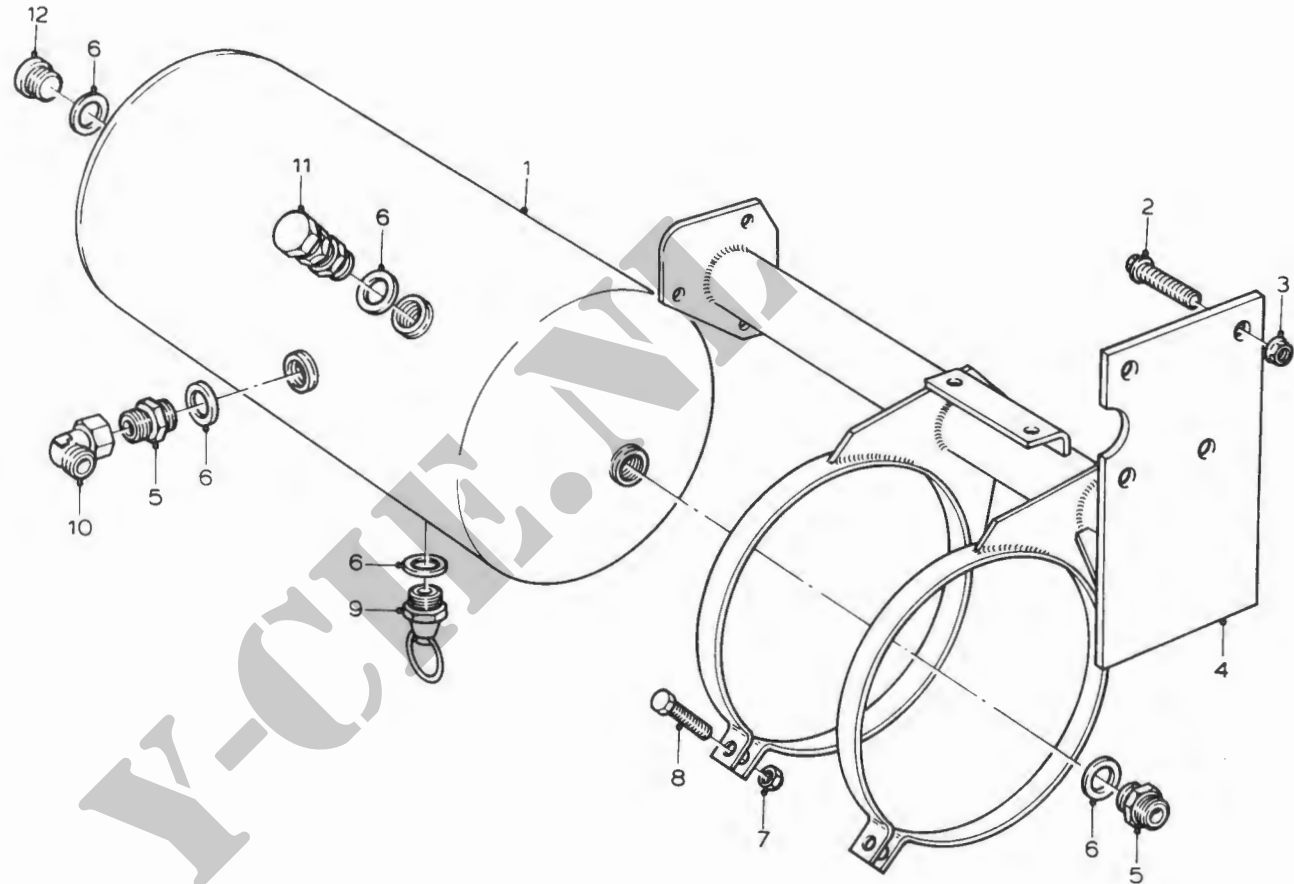
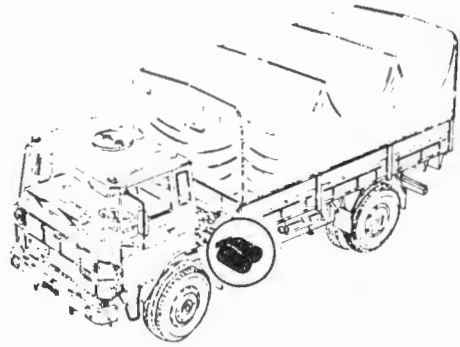

1202-0001

**YCHIE.ME**

PROJECTNUMMER: 002083  
MOSNUMMER : 1202-0001

LUCHTKETELS

DATUM 871102  
BLAD 2 VAN 2 BLADEN

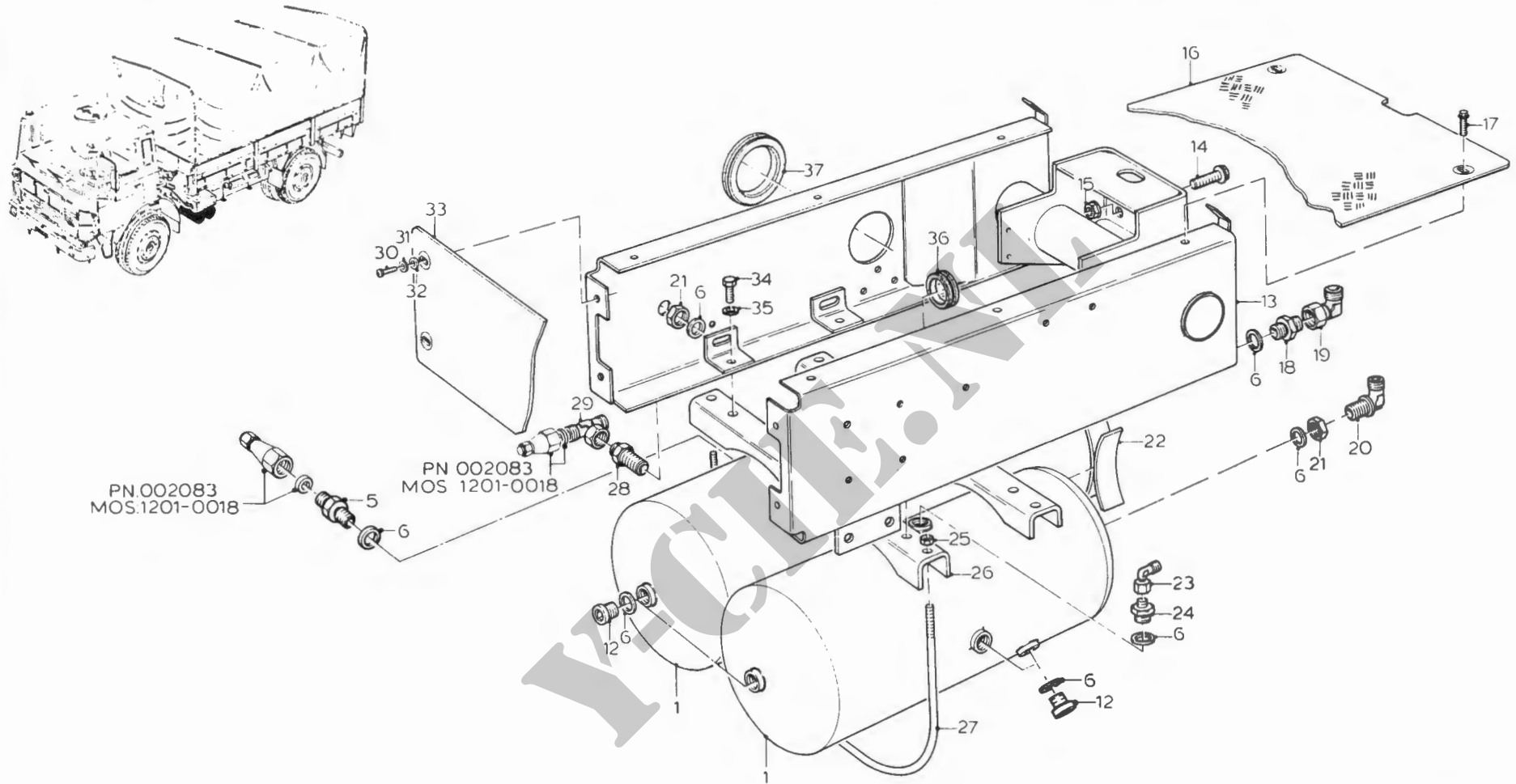

1202-0001

PN 002083

MOSNR 1202-0001

LUCHTKETELS

DATUM: 890905

BLAD: 1

FIGNR	N MC	B	NSN	C	FCN	REFRENTIENUMMER (= FAN)	ARTIKELOMSCHRIJVING TOELICHTING	AANT ECH	OPMERKINGEN
2		B	5306-17-050-7994	8	H0001	0638042	BOUT, BORST	4 2	
3		B	5310-17-050-9991	3	H0001	0638049	MOER, KRAAG, ZESKANT	4 2	
5		B	4730-17-102-9689	6	H0001	0369027	AANPASSTUK, REC	3 2	
6		B	5330-17-015-9817	3	H0001	0147120	PAKKING MET HOUDER	NB 2	
7		B	5310-12-196-3589	0	H0001	M22X1, 5X27, 0X2, 5DAFN9105 0892256	MOER, ZELFBORGEND, ZE	2 2	
8		B	5305-12-173-1848	7	H0001	0311189 DIN961-M10X1, 25X50-8.8-A2P	SCHROEF, ZESKANTE KO	2 2	
9		B	2530-12-155-0649	0	H0001	0505294 D8286 DIN74292-C	VENTIL, ENTWAESSERU	1 2	
10		B	4730-17-101-6405	0	H0001	0368984	KNIE, PYP	1 2	
11		B	0000-KL-041-0691	6	H0001	0555594 D8096 4346020110	VENTIEL	1 2	
12		B	5365-17-103-4429	5	H0001	0281264	STOP, CILINDRISCHE S	NB 2	
14		B	5306-17-050-8004	7	H0001	0638044	BOUT, MACHINE	4 2	
15		B	5310-17-050-7984	9	H0001	0638050	MOER, KRAAG, ZESKANT	4 2	
17		B	5306-12-317-5568	0	H0001	0268977 D8286 DIN6921-M8X20-8.8-A2P	BOUT, MACHINE	6 2	
18		B	0000-KL-041-0676	2	H0001	0373814	KLEMK. MET EPOXYHAR	1 2	
19		B	4730-17-103-3911	4	H0001	0373813	KNIE, PIJP	1 2	
20		B	4730-17-103-2510	0	H0001	0368986	KNIE, PYP	1 2	
21		B	5310-12-144-4041	4	H0001	0226492	MOER, ZESKANT	1 2	
23		B	4730-17-103-2509	0	H0001	0368985	KNIE, PYP	2 2	
24		B	0000-KL-041-0696	0	H0001	0369006	KLEMK. MET EPOXYHAR	2 2	
25		B	5310-17-035-8858	0	D8286	M10-1-25DIN982	MOER, ZELFBORGEND, ZE	4 2	
28		B	4730-17-103-2511	1	H0001	0368992	NIPPFL, PYP	1 2	
29		B	4730-17-103-3912	5	H0001	0368998	T-STUK, PIJP	1 2	
30		B	0000-KL-041-0700	4	H0001	0124151 D8286 DIN7985-M8X20-4.8-H-A2P	SCHROEF	4 2	
31		B	5310-12-162-2131	4	H0001	0251928 D8286 DIN128-A8	ONDERLEGRING, BORG-	4 2	
32		B	5310-12-142-0645	5	H0001	0251905 D8286 DIN125-B8, 4-ST-A3P	ONDERLEGRING, VLAK	4 2	
34		B	0000-KL-041-0633	3	H0001	0278863 D8286 DIN6921-M10X25X8.8	BOUT, FLENS-	4 2	
36		B	5325-17-025-8532	4	H0001	0325500	TULE, RUBBER	2 2	

PN 002083

LUCHTKETELS

MOSNR 1202-0001 BLAD: 1

**Y-CHE.ME**

**YCHIE.ME**

PROJECTNUMMER: 002083  
MOSNUMMER : 1202-0002

REMLEIDINGEN,-SLANGEN

DATUM 871102  
BLAD 1 VAN 2 BLADEN

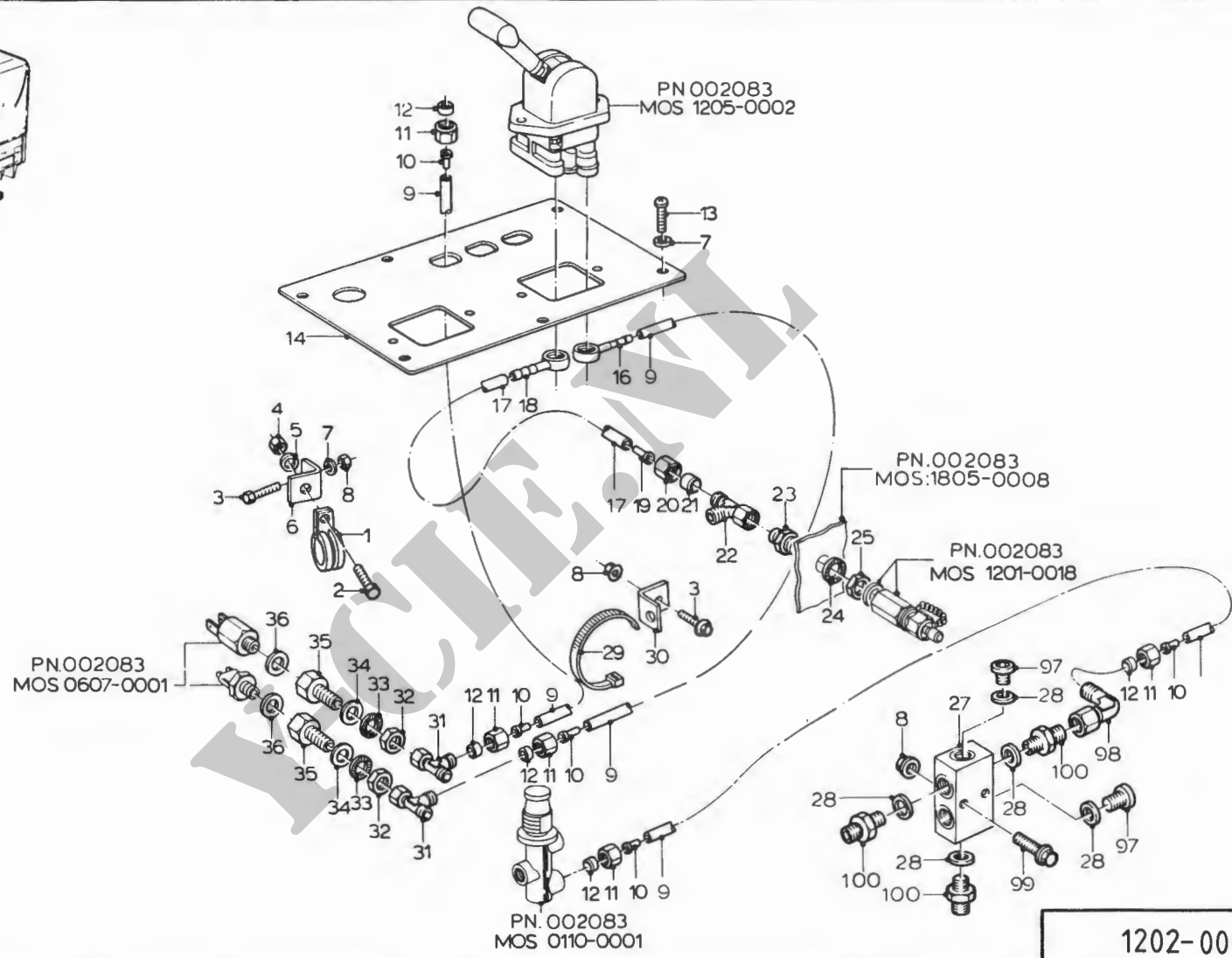

Y-CHE.ME

PROJECTNUMMER: 002083  
MOSNUMMER : 1202-0002

### REMLEIDINGEN, -SLANGEN

DATUM 871102  
BLAD 2 VAN 2 BLADEN

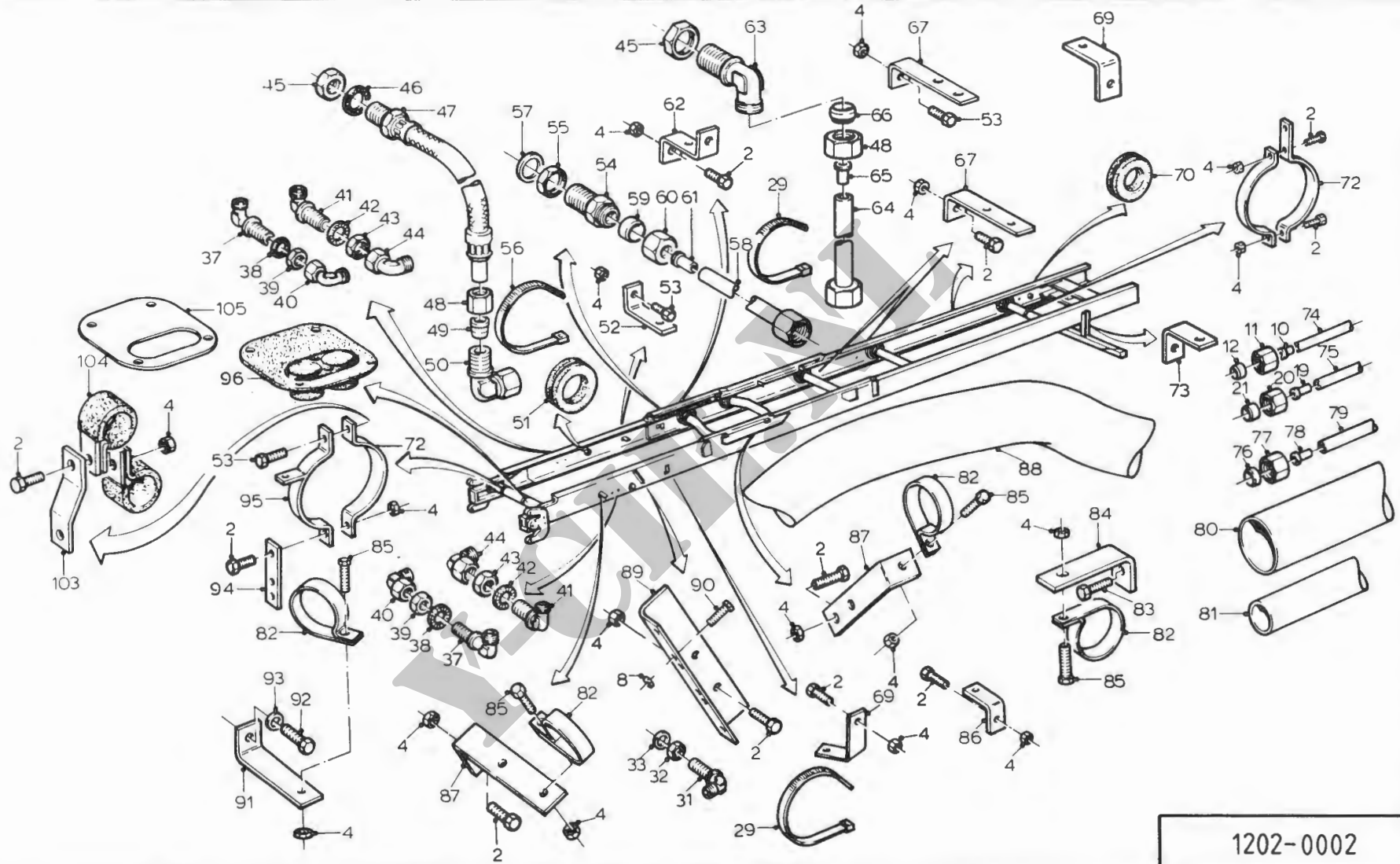

1202-0002

PN 002083

MOSNR 1202-0002

REMLEDINGEN, -SLANGEN

DATUM: 890905

BLAD: 1

FIGNR	N MC	B	NSN	C	FCN	REFERENTIENUMMER (= FAN)	ARTIKELOMSCHRIJVING	TOELICHTING	AANT ECH	OPMERKINGEN
1		B	5340-12-178-3107	6	D8286	DIN3016-D1-34X20-W1-2	KLEM, LUS		2 2	
2		B	5305-17-103-0050	4	H0001	0362030	SCHROEF, ZESKANT KOP		NB 2	
					D8286	DIN.6921 M8X25X21X18, 0X13X8.8				
3		B	0000-KL-042-7818	6	H0001	0894852	SCHROEF		NB 2	
					D8286	DIN9621-M6X16X13X14, 2X10X8.8				
4		B	5310-17-915-1028	1	H0001	0268985	MOER, FLFNS-		NB 2	
					D8286	DIN.6923 M8X17, 9X8X13X8				
7		B	5310-12-142-0644	4	D8286	DIN125-B6, 4-ST-A3P	ONDERLEGRING, VLAK		6 2	
8		B	5310-17-915-1029	2	H0001	0272563	MOER, KRAAG, ZESKANT		6 2	
					D8286	DIN6923-M6-8-A2P				
9		B	4720-12-173-8647	8	H0001	0799007	PYP, NIET METAAL		NB 2	MR
					D8286	DIN73378-PA11WSWLT-6X1				
10		B	4730-12-174-0669	6	H0001	0624109	HULS, TROMPETVORMIG,		2 2	
					D8096	8930402104				
11		B	4730-12-132-5661	6	H0001	0226483	MOER, PYPKOPPELING		2 2	
					D8286	DIN3870-AL6				
12		B	4730-12-132-5660	5	H0001	0624112	HULS, INPERS-, PYPFIT		2 2	
					H0001	0226480				
13		B	5305-12-166-3829	1	H0001	0318916	SCHROEF, MACHINE		6 2	
					D8286	DIN7985-M6X16-4.8-H-A2P				
16		B	0000-KL-041-0708	1	H0001	0392866	HUIS, BANJO-		1 2	
17		B	4720-12-173-8649	0	H0001	0959033	PYP, NIET-METAAL		NB 2	MR
					D8286	DIN73378-PA11WSWLT-8X1				
18		B	0000-KL-041-0710	3	H0001	0371189	HUIS, BANJO-		1 2	
19		B	3120-17-054-6692	8	H0001	0633242	BUS, NAAFREDUCTIE		1 2	
					H0001	6X8X0, 50X15.DAFN.9105				
20		B	4730-12-124-4265	0	H0001	0205035	MOER, PYPKOPPELING		1 2	
					D8286	DIN3870-AL8				
21		B	4730-12-136-8560	5	H0001	0633245	HULS, INPERS-, PYPFIT		1 2	
					D8286	DIN3861-L8-ST-A3P				
22		B	4730-17-103-3915	8	H0001	0369003	KNIE, PIJP		1 2	
23		B	0000-KL-041-0509	0	H0001	0370843	KLEMK. MET EPOXYHAR		1 2	
24		B	5310-12-124-0895	6	H0001	0584882	ONDERLEGRING, BORG-		1 2	
					D8286	DIN6798-A14, 5				
25		B	5310-12-144-2164	8	H0001	0226491	MOER, ZESKANT		1 2	
					D8286	DIN80705-M14X1, 5-A2P				
28		B	5330-17-050-2436	5	H0001	0260901	PAKINGRING MET HOU		7 2	
29		B	5975-00-451-5001	7	H0001	0657954	RIEM, BIND-, ELEKTRIS		NB 2	
					06383	SST4HC				
31		B	4730-17-103-1544	2	H0001	0369001	T-STUK, PIJP		2 2	
32		B	5310-12-144-2186	8	H0001	0226490	MOER, ZESKANT		4 2	
					D8286	DIN80705-M12X1, 5-A2P				

PN 002083

REMLEDINGEN, -SLANGEN

MOSNR 1202-0002 BLAD:

1

FIGNR	N MC	B	NSN	C	FCN	REFERENTIENUMMER (= FAN)	ARTIKELOMSCHRIJVING TOELICHTING	AANT ECH	OPMERKINGEN
33		B	5310-12-124-0894	5	H0001	0251941	ONDERLEGRING, BORG-	4 2	
					D8286	DIN6798-A12,5			
34		B	5310-12-156-4899	5	H0001	0202950	ONDERLEGRING, VLAK	4 2	
					D8286	DIN125-B13-ST-A3P			
35		B	0000-KL-041-0714	7	H0001	0373898	KLEMK. MET EPOXYHAR	4 2	
36		B	5330-17-049-8488	6	H0001	0206786	PAKKINGRING MET HOU	4 2	
					H0001	M12X1,5X16X2,5 DAFN.9105			
37		B	4730-17-101-4758	2	H0001	0368989	KNIE, PYP	2 2	
38		B	5310-12-131-4169	9	H0001	0251942	ONDERLEGRING, BORG-	2 2	
					D8286	DIN6798-A16,5			
39		B	5310-12-145-2077	0	H0001	0107233	MOER, ZESKANT	2 2	
					D8286	DIN80705-M16X1,5-A2P			
40		B	4730-17-101-5285	1	H0001	0285443	KNIE, PYP	3 2	
41		B	4730-17-101-5461	1	H0001	0368987	KNIE, PYP	2 2	
42		B	5310-12-196-5809	9	H0001	0674631	ONDERLEGRING, BORG-	2 2	
					D8286	DIN6798-A19			
43		B	5310-12-131-4478	0	H0001	0124399	MOER (1), ZESKANT	2 2	
					D8286	DIN80705-M18X1,5			
44		B	4730-17-101-5455	6	H0001	0285449	KNIE, PYP	3 2	
45		B	5310-12-145-2081	3	H0001	0541284	MOER, ZESKANT	1 2	
					D8286	DIN80705-M26X1,5-A2P			
47		B	0000-KL-041-0716	9	H0001	0396763	SLANG REMINSTALLATI	1 2	
48		B	4730-12-145-1962	5	H0001	0541285	MOER, PYPKOPPELING	NB 2	
					D8286	DIN3870-AL18-A3P			
49		B	4730-12-132-7451	3	H0001	0226482	HULS, INPERS-, PYPFIT	1 2	
					D8286	DIN3861-L18-ST-A3P			
50		B	4730-12-164-4546	1	H0001	0507953	KNIE, PYP	1 2	
					D8286	DIN3952-L18-ST			
51		B	5325-17-054-8778	4	H0001	0279340	TULE, RUBBER	1 2	
53		B	0000-KL-042-2971	0	H0001	0286503	BOUT, FLENS-	NB 2	
					D8286	DIN.6921 M8X30X22X18,0X13X8.8			
54		B	4730-17-103-2511	1	H0001	0368992	NIPPEL, PYP	1 2	
55		B	5310-12-144-4041	4	H0001	0226492	MOER, ZESKANT	1 2	
					D8286	DIN74305-M22X1,5-A2P			
56		B	5975-00-074-2072	1	H0001	0261657	RIEM, BIND-, ELEKTRIS	NB 2	
57		B	5310-12-151-1576	0	H0001	0674630	ONDERLEGRING, BORG-	1 2	
					D8286	DIN6798-A23			
58		B	4720-17-051-0795	4	H0001	0799006	SLANG, NIET-METAAL	NB 2	MR
					D8286	DIN73378-15X2XZT			
59		B	4730-12-131-3696	9	H0001	0624114	HULS, INPERS-, PYPFIT	1 2	
					D8286	DIN3861-L15-ST-A3P			

PN 002083

MOSNR 1202-0002

REMLEIDINGEN, -SLANGEN

DATUM: 890905

BLAD:

3

FIGNR	N	MC	B	NSN	C	FCN	REFFRENTIENUMMER (= FAN)	ARTIKELOMSCHRIJVING TOELICHTING	AANT ECH	OPMERKINGEN
60			B	4730-12-132-1910	6	H0001	0719243	MOER, PYPKOPPELING	1	2
						D8286	DIN3870-AL15			
61			B	5320-17-052-7399	9	H0001	0624111	KLINKNAGEL, BUISVORM	1	2
				4730-12-172-5861						DIT NSN IS VERVALLEN BIJ BESTELLING
63			B	0000-KL-041-0720	2	H0001	0373453	KLEMK. MET EPOXYHAR	1	2
64			B	4710-12-300-3024	1	H0001	0799023	SLANG, NIET-METAAL	NB	2 MR
						D8286	DIN73378-PA11WSWLT-18X2			
65			B	4730-17-054-8734	4	H0001	0812041	VERSTERKINGSHULS	2	2
						H0001	14X18X0, 75X18. DAFN. 9103			
66			B	4730-12-132-7451	3	H0001	0226482	HULS, INPERS-, PYPFIT	2	2
70			B	5325-17-025-8532	4	H0001	0325500	TULE, RUBBER	2	2
74			B	4720-12-173-8647	8	H0001	0799007	PYP, NIET METAAL.	NB	2 MR
						D8286	DIN73378-PA11WSWLT-6X1			
75			B	4720-12-173-8649	0	H0001	0259033	PYP, NIET-METAAL	NB	2 MR
						D8286	DIN73378-PA11WSWLT-8X1			
76			B	4730-12-172-1015	9	H0001	0624113	HULS, COMPRESSIE, PYP	NB	2
						D9596	022065			
77			B	4730-12-123-4179	0	H0001	0146142	MOER, PYPKOPPELING	NB	2
						D8286	DIN3870-AL10			
78			B	4730-17-050-2609	2	H0001	0624110	VERSTERKINGSHULS	NB	2
						H0001	7, 5X10X0, 75X15 DAFN. 9103			
79			B	4720-12-317-5828	6	H0001	0799005	SLANG, NIET-METAAL	NB	2 MR
						D8286	DIN74324-10X1,25			
80			B	0000-KL-041-0725	7	H0001	0392960	SLANG	NB	2
81			B	0000-KL-041-0726	8	H0001	0392961	SLANG	NB	2
82			B	5340-17-054-9872	9	H0001	0668650	KLEM, LUS	5	2
83			B	5306-12-317-5568	0	H0001	0268977	BOUT, MACHINE	1	2
						D8286	DIN6921-M8X20-8.8-A2P			
85			B	5306-12-317-5568	0	H0001	0268977	BOUT, MACHINE	5	2
						D8286	DIN6921-M8X20-8.8-A2P			
88			B	0000-KL-041-0728	0	H0001	0388656	SLANG	1	2
90			B	5306-17-910-8561	5			BOUT, FLENS-	6	2
92			B	5305-12-141-9888	7	H0001	0251631	SCHROEF, ZESKANTE KO	1	2
						D8286	DIN933-M10X20-8.8-A3P			
93			B	5310-12-162-2130	3	H0001	0251929	ONDERLEGRING, BORG-	1	2
						D8286	DIN128-A10			
96			B	0000-KL-042-9988	9	H0001	0076310	TULE	1	2
97			B	5365-12-134-6167	8	H0001	0547744	STOP, CILINDRISCHE S	2	2
						D8286	DIN910-M16X1,5-ST			
98			B	4730-17-101-5458	9	H0001	0285448	KNIE, PYP	1	2

PN 002083

REMLEIDINGEN, -SLANGEN

MOSNR 1202-0002 BLAD:

3

PN 002083

MOSNR 1202-0002

REMLEDINGEN, -SLANGEN

DATUM: 890905 BLAD: 4

FIGNR	N	MC	B	NSN	C	FCN	REFERENTIE NUMMER (= FAN)	ARTIKELOMSCHRIJVING	TOELICHTING	AANT	ECH	OPMERKINGEN
99			B	0000-KL-042-7819	7	H0001	0293900	BOUT, FLENS		2	2	
						D8286	DIN6921-M6X50X18X14, 2X10X8.8					
100			B	0000-KL-041-0672	9	H0001	0285457	KLEMK. MET EPOXYHAR		1	2	
104			B	5340-12-173-6519	3	H0001	0107134	KLEM, LUS		2	2	
						D8286	DIN3016-D1-28X20-W1-2					

Y-CHE.ML

PN 002083

REMLEDINGEN, -SLANGEN

MOSNR 1202-0002 BLAD: 4

86

-LAATSTE BLAD-

**Y-CHE.ME**

PROJECTNUMMER: 002083  
MOSNUMMER : 1202-0003

KOELLEIDING

DATUM 871102  
BLAD 1 VAN 1 BLADEN

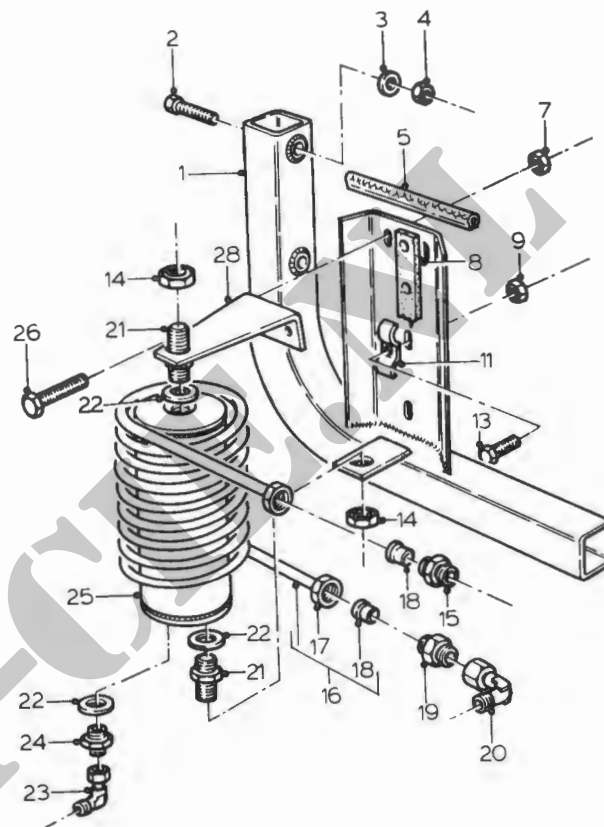

1202-0003

PN 002083

MOSNR 1202-0003

KOELLEIDING

DATUM: 890905

BLAD: 1

FIGNR	N MC	B	NSN	C	FCN	REFERENTIENUMMER (= FAN)	ARTIKELOMSCHRIJVING TOELICHTING	AANT ECH	OPMERKINGEN
2		B	5305-12-142-5192	9	H0001	0311090	SCHROEF, ZESKANTE KO	2 2	
					D8286	DIN960-M14X1,5X90-10.9-A3P			
3		B	5310-12-167-1520	3	H0001	0251931	ONDERLEGRING, BORG-	2 2	
					D8286	DIN128-A14			
4		B	5310-12-144-6164	4	H0001	0325195	MOER, ZESKANT	2 2	
					D8286	DIN934-M14X1,5-8-A2P			
5		B	9390-12-170-6671	9	H0001	0225623	NONMETALLIC CHANNEL	NB 2	MR
7		B	5310-17-915-1028	1	H0001	0268985	MOER, FLENS-	2 2	
					D8286	DIN6923 M8X17,9X8X13X8			
9		B	5310-17-915-1029	2	H0001	0272563	MOER, KRAAG, ZESKANT	3 2	
					D8286	DIN6923-M6-8-A2P			
11		B	5340-17-017-4581	5	H0001	0324183	BEUGEL, INSTALLATIE	3 2	
13		B	5305-12-141-9850	2	D8286	DIN933-M6X40-8.8-A2P	SCHROEF, ZESKANTE KO	3 2	
14		B	5310-12-144-4041	4	H0001	0226492	MOER, ZESKANT	2 2	
					D8286	DIN74305-M22X1,5-A2P			
15		B	4730-17-103-3913	6	H0001	0637672	NIPPEL, PIJP	1 2	
16		B	4710-17-103-3736	5	H0001	0387057	PIJPSAMENSTEL, META	1 2	
17		B	4730-12-145-1962	5	H0001	0541285	MOER, PYPKOPPELING	2 2	
					D8286	DIN3870-AL18-A3P			
18		B	4730-12-132-7451	3	H0001	0226482	HULS, INPERS-, PYPFIT	1202/0003/00016	
					D8286	DIN3861-L18-ST-A3P		2 2	
19		B	0000-KL-041-0738	9	H0001	0373021	KLEMK. MET EPOXYHAR	1 2	
20		B	4730-17-101-6405	0	H0001	0368984	KNIE, PYP	1 2	
21		B	5307-17-103-3918	0	H0001	0286979	TAPEIND, BORST	2 2	
22		B	5330-17-015-9817	3	H0001	0147120	PAKKING MET HOUDER	3 2	
					H0001	M22X1,5X27,0X2,5DAFN9105			
23		B	4730-17-101-5458	9	H0001	0285448	KNIE, PYP	1 2	
24		B	0000-KL-041-0740	0	H0001	0285441	KLEMK. MET EPOXYHAR	1 2	
26		B	5305-17-103-0050	4	H0001	0362030	SCHROEF, ZESKANT KOP	2 2	
					D8286	DIN6923 M8X25X21X18,0X13X8.8			

PN 002083

KOELLEIDING

MOSNR 1202-0003

BLAD: 1

87

-LAATSTE BLAD-

**YCHIE.ME**

**Y-CHE.ME**

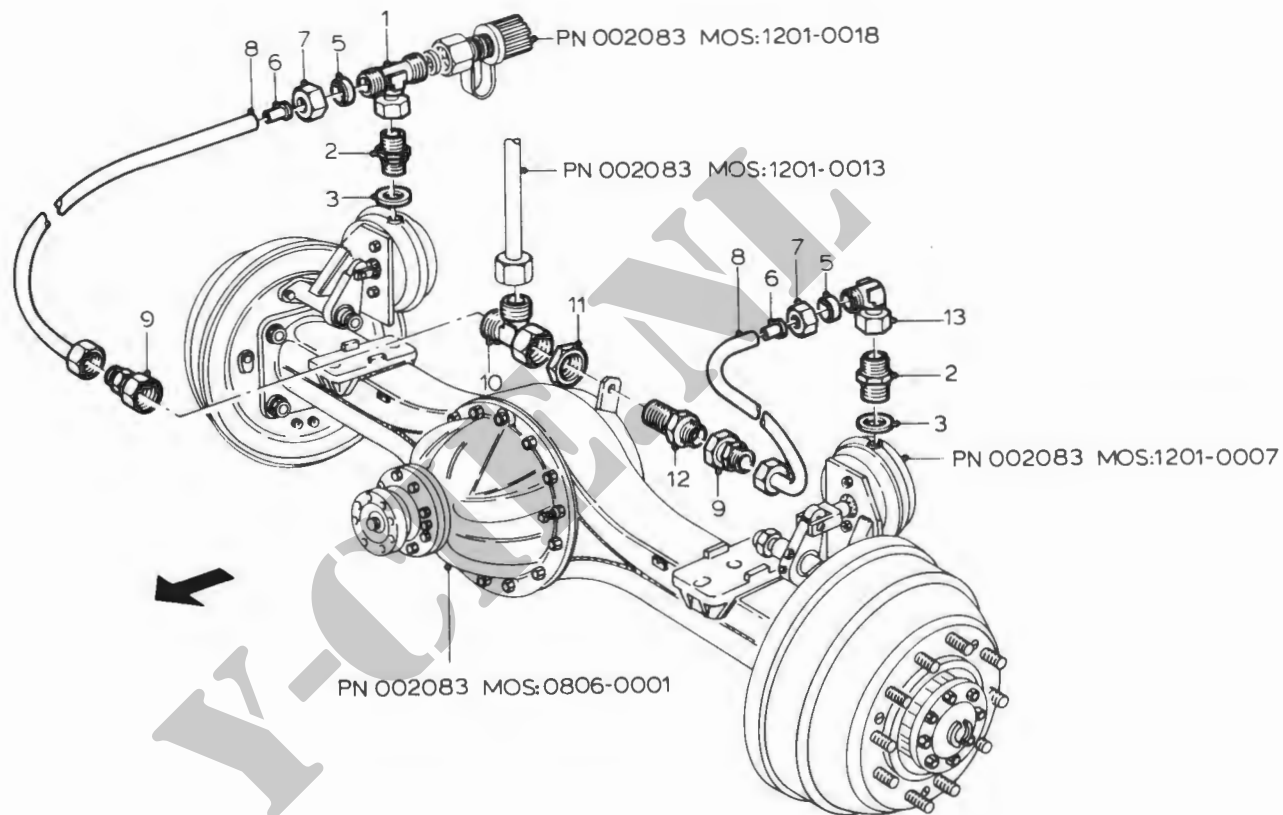

PN 002083

MOSNR 1202-0004

REMLEIDINGEN ACHTERAS

DATUM: 890905

BLAD: 1

FIGNR	N	MC	B	NSN	C	FCN	REFERENTIENUMMER (= FAN)	ARTIKELOMSCHRIJVING TOELICHTING	AANT ECH	OPMERKINGEN	
1			B	4730-17-102-9688	5	H0001	0369228	T-STUK, PIJP	1	2	
2			B	4730-17-101-3977	2	H0001	0285456	VERLOOPSTUK, PYP	2	2	
3			B	5330-17-050-2436	5	H0001	0260901	PAKINGRING MET HOU	2	2	
5			B	4730-12-132-1953	5	H0001	0633246	HULS, INPERS-, PYPFIT	4	2	
						D8286	DIN3861-L12-ST-A3P				
6			B	4730-12-174-0670	7	H0001	0649254	HULS, TROMPETVORMIG,	4	2	
7			B	4730-12-132-1954	6	H0001	0238007	MOER, PYPKOPPELING	4	2	
						D8286	DIN3870-AL12				
8			B	4710-12-198-6974	0	H0001	0799008	BUIS, KUNSTSTOF	2	2	MR
						D8286	DIN73378-PA11WSWT-12X1,5				
9			B	0000-KL-041-0636	6	H0001	0369009	KLEMK. MET EPOXYHAR	2	2	
10			B	4730-17-101-6255	3	H0001	0369002	T-STUK, PIJP	1	2	
11			B	5310-12-144-4041	4	H0001	0226492	MOER, ZESKANT	1	2	
						D8286	DIN74305-M22X1,5-A2P				
12			B	4730-17-103-2511	1	H0001	0368992	NIPPEL, PYP	1	2	
13			B	4730-17-101-5455	6	H0001	0285449	KNIE, PYP	1	2	

PN 002083

REMLEIDINGEN ACHTERAS

MOSNR 1202-0004 BLAD: 1

-LAATSTE BLAD-

**Y-CHE.ME**

**Y-CHE.ME**

PROJECTNUMMER: 002083

MOSNUMMER : 1202-0005

LEIDINGKOPPELINGEN

DATUM 871102

BLAD 1 VAN 1 BLADEN

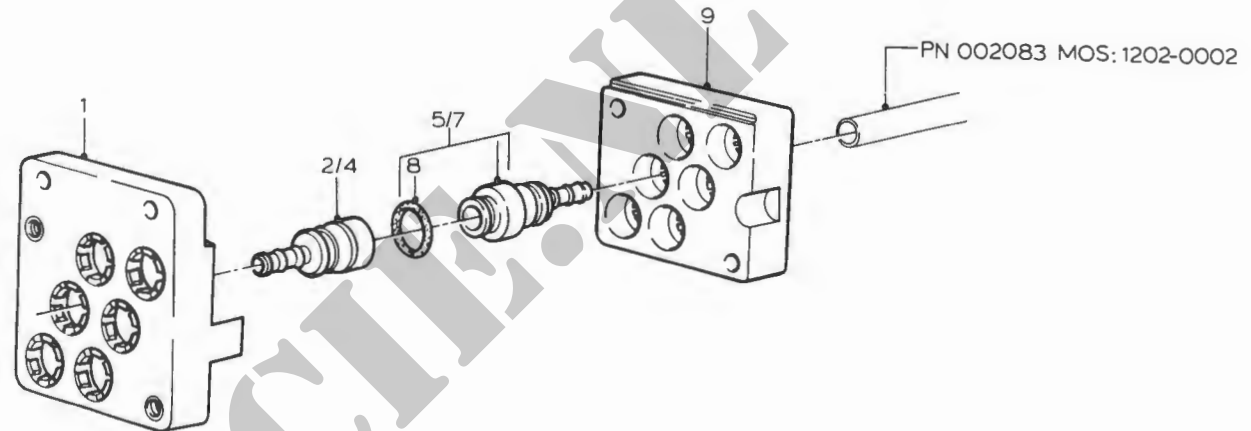
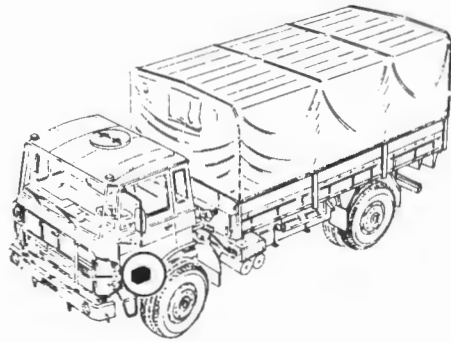

1202-0005

PN 002083

MOSNR 1202-0005

LEIDINGKOPPELINGEN

DATUM: 890905

BLAD: 1

FIGNR	N MC	B	NSN	C	FCN	REFERENTIENUMMER (= FAN)	ARTIKELOMSCHRIJVING TOELICHTING	AANT ECH	OPMERKINGEN
1		B	4730-12-300-1559	0	H0001	0661795	KOPPELINGHELFT, SNEL	3 2	
					D9596	843499			
2		B	4730-12-300-1553	4	H0001	0661788	KOPPELINGHELFT, SNEL	1 2	
					D9596	843745			
3		B	4730-12-300-1557	8	H0001	0661792	KOPPELINGHELFT, SNEL	5 2	
					D9596	843875			
4		B	4730-12-300-1555	6	H0001	0661790	KOPPELINGHELFT, SNEL	2 2	
					D9596	843885			
5		B	4730-12-300-1552	3	H0001	0661787	KOPPELINGHELFT, SNEL	1 2	
					D9596	843545			
6		B	4730-12-300-1556	7	H0001	0661791	KOPPELINGHELFT, SNEL	3 2	
					D9596	843675			
7		B	4730-12-300-1554	5	H0001	0661789	KOPPELINGHELFT, SNEL	3 2	
					D9596	843685			
8		B	5330-12-152-8654	5	H0001	0689209	PAKKING, VOORGEVORMD	NB 2	
					D9596	906839-70			
9		B	4730-12-300-1560	0	H0001	0661796	KOPPELINGHELFT, SNEL	3 2	
					D9596	843489			

PN 002083

LEIDINGKOPPELINGEN

MOSNR 1202-0005 BLAD: 1

**Y-CHE.ME**

**Y-CHE.ME**



PN 002083

MOSNR 1203-0001

COMPRESSOR

DATUM: 890905

BLAD: 1

FIGNR	N MC	B	NSN	C	FCN	REFERENTIENUMMER (= FAN)	ARTIKELOMSCHRIJVING TOELICHTING	AANT ECH	OPMERKINGEN
2		B	5330-12-124-1000	1	H0001	0119135	GASKET	3 2	
3		B	0000-KL-041-0743	3	D8286	DIN7603-A26X32-CU	BOUT, BANJO-	1 2	
5		B	5340-12-144-4077	7	H0001	0202535	KLEM, LUS	2 2	
6		B	5310-12-162-2131	4	D8286	DIN7623-DXM26X1,5X20X13,5	ONDERLEGRING, BORG-	4 2	
7		B	5310-12-144-6214	0	H0001	0519070	MOER, ZESKANT	4 2	
8		B	2815-17-103-3985	1	D8286	DIN3016-D1-18X20-W1-2	LEIDING, KOMPRESSOR	1 2	
9		B	4730-12-145-1962	5	H0001	0251928	MOER, PYPKOPPELING	3 2	
					D8286	DIN128-A8			
					H0001	0251275			
					D8286	DIN934-M8-8-A2P			
					H0001	0538246			
					D8286	DIN3870-AL18-A3P			
10		B	4730-12-132-7451	3	H0001	0226482	HULS, INPERS-, PYPFIT	1203/0001/00008	
					D8286	DIN3861-L18-ST-A3P		3 2	
17		B	4730-17-103-3914	7	H0001	0665423	NIPPEL, PIJP	1203/0001/00008	
18		B	5310-12-145-2081	3	H0001	0541284	MOER, ZESKANT	1 2	
					D8286	DIN80705-M26X1,5-A2P		1 2	
19		B	5330-17-015-9817	3	H0001	0147120	PAKKING MET HOUDER	1 2	
					H0001	M22X1,5X27,0X2,5 DAFN.9105			
20		B	4730-17-103-0390	3	H0001	0292033	KNIE, PIJP	1 2	
21		B	4730-17-102-9709	4	H0001	0173715	KLEM, SLANG	2 2	
					S5628	TYPE1-A22-32			
22		B	4720-17-103-4287	6	H0001	0369523	SLANG, VOORGEVORMD	1 2	
23		B	4730-17-102-9734	7	H0001	0269509	AANPASSTUK (1), REC	1 2	
25		B	4730-17-103-3913	6	H0001	0637672	NIPPEL, PIJP	1 2	
26		B	0000-KL-044-2369	4	H0001	0892719	LEIDING KOMPRESSOR	1 2	

PN 002083

COMPRESSOR

MOSNR 1203-0001 BLAD:

1

90

-LAATSTE BLAD-

**Y-CHE.ME**

**Y-CHE.ME**

PROJECTNUMMER: 002083  
MOSNUMMER : 1204-0001

REMSCHOEN EN NOKAS VOOR

DATUM 871102  
BLAD 1 VAN 1 BLADEN

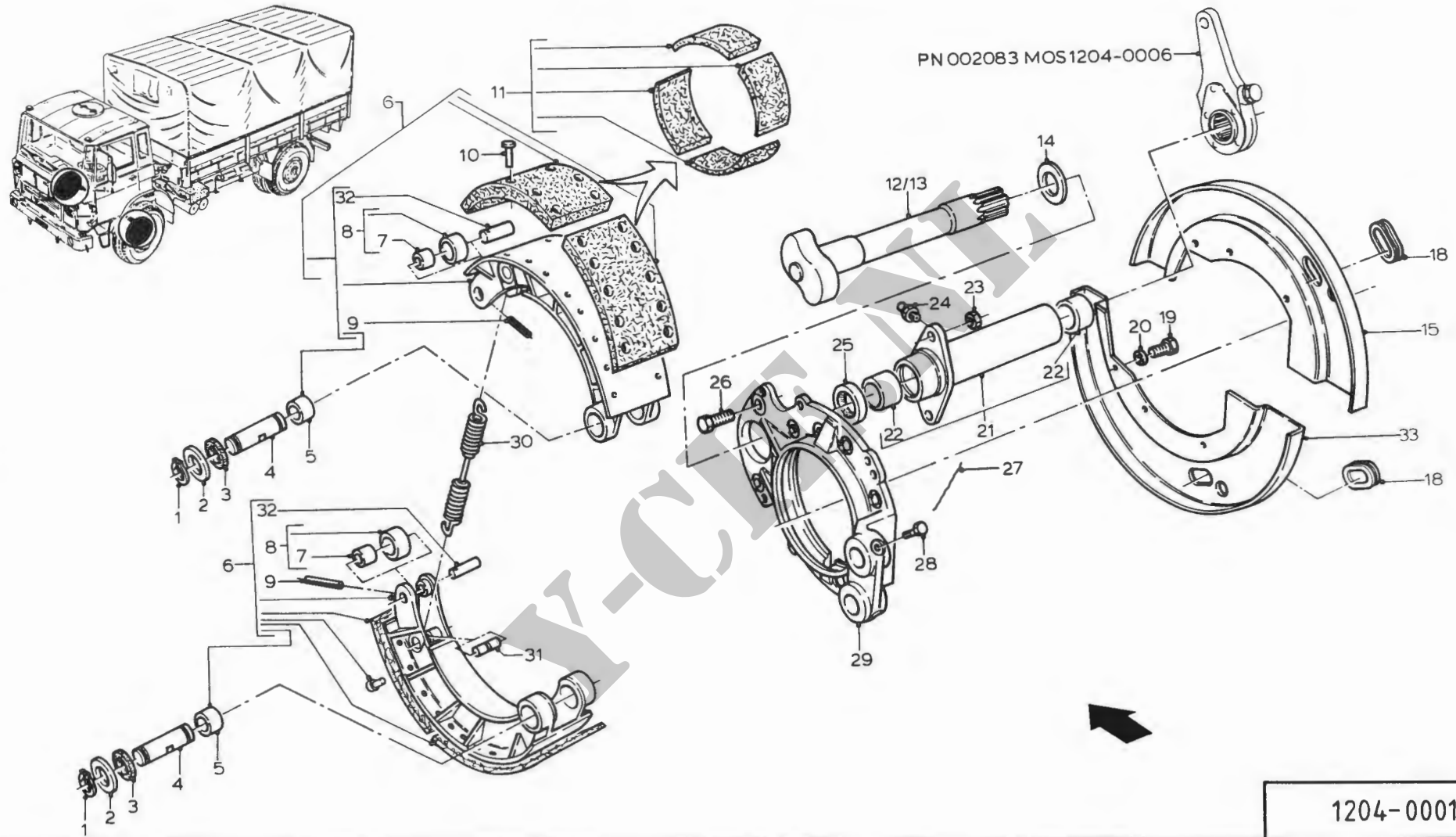

1204-0001

PN 002083

MOSNR 1204-0001

REMSCHOEN EN NOKAS VOOR

DATUM: 890905

BLAD: 1

FIGNR	N	MC	B	NSN	C	FCN	REFERENTIENUMMER (= FAN)	ARTIKELOMSCHRIJVING TOELICHTING	AANT	ECH	OPMERKINGEN
1			B	5365-12-156-4439	7	H0001	0251986	RING, BORG-, VEREND	8	2	
						D8286	DIN471-32X1,5				
2			B	5310-17-025-7434	6	H0001	0145452	ONDERLEGRING, VERZON	8	2	
3			B	5330-17-022-8609	1	H0001	0145451	VILT, TECHNISCH, VOOR	8	2	
4			B	5315-17-025-3166	6	H0001	0145450	PEN, GEGROEFD, ZONDER	4	2	
18			B	5340-17-103-4239	2	H0001	0528777	KAP, BESCHERM-, STOF	4	2	
19			B	5305-12-141-9861	2	H0001	0251619	SCHROEF, ZESKANTE KO	12	2	
						D8286	DIN933-M8X12-8.8-A2P				
20			B	5310-12-162-2131	4	H0001	0251928	ONDERLEGRING, BORG-	12	2	
						D8286	DIN128-A8				
24			B	4730-17-007-1812	9	H0001	0119172	NIPPEL, SMEER-	2	2	
28			B	5305-17-054-7986	4	H0001	0503809	SCHROEF, ZESKANTE KO	4	2	
30			B	5360-17-708-6962	8	H0001	0194592	VEER, TREK-, SCHROEFL	2	2	

PN 002083

REMSCHOEN EN NOKAS VOOR

MOSNR 1204-0001 BLAD:

1

91

-LAATSTE BLAD-

**Y-CHE.ME**

**Y-CHE.ME**



PN 002083

MOSNR 1204-0003

REMSCHOEN EN NOKAS ACHTER

DATUM: 890905

BLAD: 1

FIGNR	N MC	B	NSN	C	FCN	REFERENTIENUMMER (= FAN)	ARTIKELOMSCHRIJVING TOELICHTING	AANT ECH	OPMERKINGEN
3		B	5315-17-025-3166	6	H0001	0145450	PEN, GEGROEFD, ZONDER	4 2	
4		B	5330-17-022-8609	1	H0001	0145451	VILT, TECHNISCH, VOOR	8 2	
5		B	5310-17-025-7434	6	H0001	0145452	ONDERLEGRING, VERZON	8 2	
6		B	5365-12-156-4439	7	H0001	0251986	RING, BORG-, VEREND	8 2	
						D8286 DIN471-32X1,5			
8		B			H0001	0145653	BOUT, ZESKANT,	4 2	
9		B	9505-17-025-8669	9	H0001	0324805	METAALDRAAD, NIET-EL	NB 2	MR
			9505-12-141-8038			D8286 DIN177-1,5X0L			DIT NSN IS VERVALLEN BIJ BESTELLING
11		B	5340-17-103-4239	2	H0001	0528777	KAP, BESCHERM-, STOF	2 2	
14		B	5306-00-225-9084	3	H0001	0251559	SCHROEF, ZESKANTE KO	12 2	
						96906 MS90726-29			
19		B	4730-17-007-1812	9	H0001	0119172	NIPPEL, SMEER-	1 2	
25		B	5360-17-708-6962	8	H0001	0194592	VEER, TREK-, SCHROEFL	2 2	

PN 002083

REMSCHOEN EN NOKAS ACHTER

MOSNR 1204-0003

BLAD: 1

92

-LAATSTE BLAD-

**Y-CHE.ME**

**YCHIE.ME**

PROJECTNUMMER: 002083  
MOSNUMMER : 1206-0001

BEDIENINGSKLEP VOLGW.

DATUM 871102  
BLAD 1 VAN 1 BLADEN

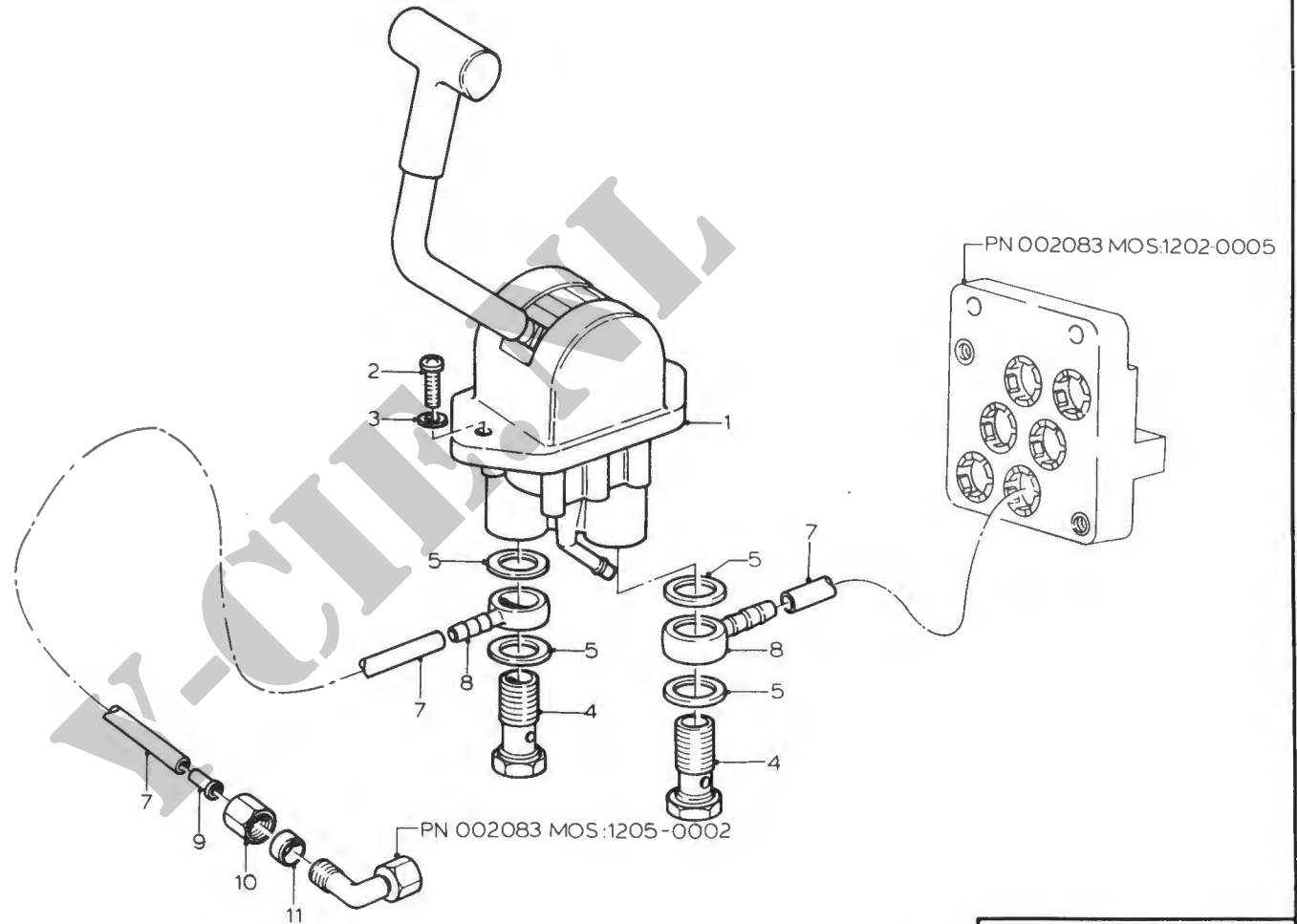
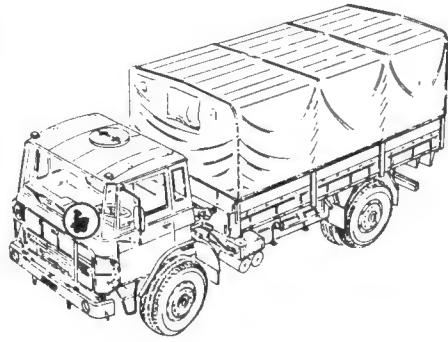

1206-0001

PN 002083

MOSNR 1206-0001

BEDIENINGSKLEP VOLGW.

DATUM: 890905

BLAD: 1

FIGNR	N	MC	B	NSN	C	FCN	REFERENTIENUMMER (= FAN)	ARTIKELOMSCHRIJVING TOELICHTING	AANT ECH	OPMERKINGEN
4			B	0000-KL-041-0631	1	H0001	0309114	BOUT, BANJO-	2 2	
						D8286	DIN7623-CXM16X11XA10			
5			B	5330-12-156-4525	5	H0001	0322364	GASKET	4 2	
						D8286	DIN7603-A16X22-CU			
7			B	4720-12-173-8647	8	H0001	0799007	PYP, NIET METAAL	NB 2	MR
						D8286	DIN73378-PA11WSWLT-6X1			
8			B	0000-KL-041-0708	1	H0001	0392866	HUIS, BANJO-	2 2	
9			B	4730-12-174-0669	6	H0001	0624109	HULS, TROMPETVORMIG,	1 2	
						D8096	8930402104			
10			B	4730-12-132-5661	6	H0001	0226483	MOER, PYPKOPPELING	1 2	
						D8286	DIN3870-AL6			
11			B	4730-12-132-5660	5	H0001	0624112	HULS, INPERS-, PYPFIT	1 2	
						D8286	DIN3861-L6-ST-A3P			

PN 002083

BEDIENINGSKLEP VOLGW.

MOSNR 1206-0001 BLAD: 1

-LAATSTE BLAD-

**Y-CHE.ME**

**YCHIE.ME**

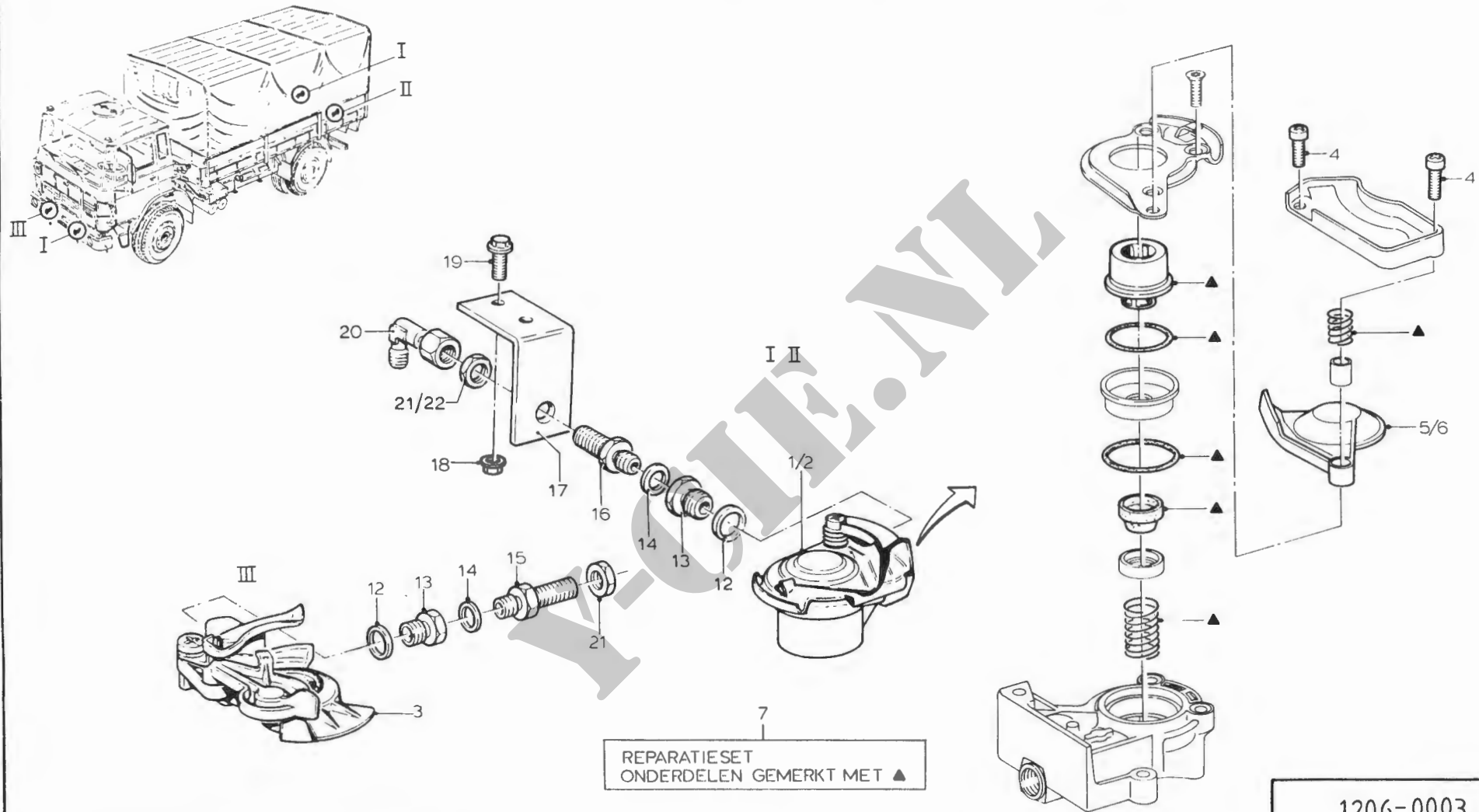

NIET GE NUMMERDE DELEN NIET LOS LEVERBAAR

1206-0003

PN 002083

MOSNR 1206-0003

KOPPELINGSKOPPEN VOLGWAGEN

DATUM: 890905

BLAD: 1

FIGNR	N	MC	B	NSN	C	FCN	REFERENTIENUMMER (= FAN)	ARTIKELOMSCHRIJVING	TOELICHTING	AANT	ECH	OPMERKINGEN
1			B	4730-12-175-2290	0	H0001	0632565	KOPPELINGHELFT, SNEL	VOORRAAD	2	2	
						D8096	9522002210					
2			B	4730-12-196-0573	9	H0001	0632566	KOPPELINGHELFT, SNEL	COMMANDO	1	2	
						D8096	9522002220					
3			B	4730-17-051-4261	5	H0001	0651235	KOPPELINGSKOP	COMMANDO	1	2	
4			B	5305-12-142-5640	6	H0001	0507257	SCHROEF, MACHINE		1	2	
						D8286	DIN7985-M6X30-4.8-H-A3P					
12			B	5330-17-050-2436	5	H0001	0260901	PAKKINGRING MET HOU		4	2	
13			B	4730-17-054-0945	3	H0001	0511929	VERLOOPSTUK, PYP		1	2	
14			B	5330-17-015-9817	3	H0001	0147120	PAKKING MET HOUDER		1	2	
						H0001	M22X1,5X27,0X2,5DAFN9105					
15			B	4730-17-101-5637	1	H0001	0368995	NIPPEL, PYP		2	2	
						H0001	RL10 DIN2353 ST					
16			B	0000-KL-041-0801	6	H0001	0368993	KLEMK. MET EPOXYHAR		2	2	
18			B	5310-17-915-1028	1	H0001	0268985	MOER, FLENS-		4	2	
						D8286	DIN6923-M8X17,9X8X13X8					
19			B	5305-17-103-0050	4	H0001	0362030	SCHROEF, ZESKANT KOP		4	2	
						D8286	DIN6921-M8X25X21X18,0X13X8.8					
20			B	4730-17-101-5455	6	H0001	0285449	KNIE, PYP		1	2	
21			B	5310-12-145-2077	0	H0001	0107233	MOER, ZESKANT	L.A. + R.V.	1	2	
						D8286	DIN80705-M16X1,5-A2P					
22			B	5310-12-131-4478	0	H0001	0124399	MOER (1), ZESKANT		3	2	

PN 002083

KOPPELINGSKOPPEN VOLGWAGEN

MOSNR 1206-0003 BLAD:

1

**Y-CHE.ME**

**YCHIE.ME**

PROJECTNUMMER: 002083  
MOSNUMMER : 1206-0004

# BUFFER RESERVOIR

DATUM 871102  
BLAD 1 VAN 1 BLADEN

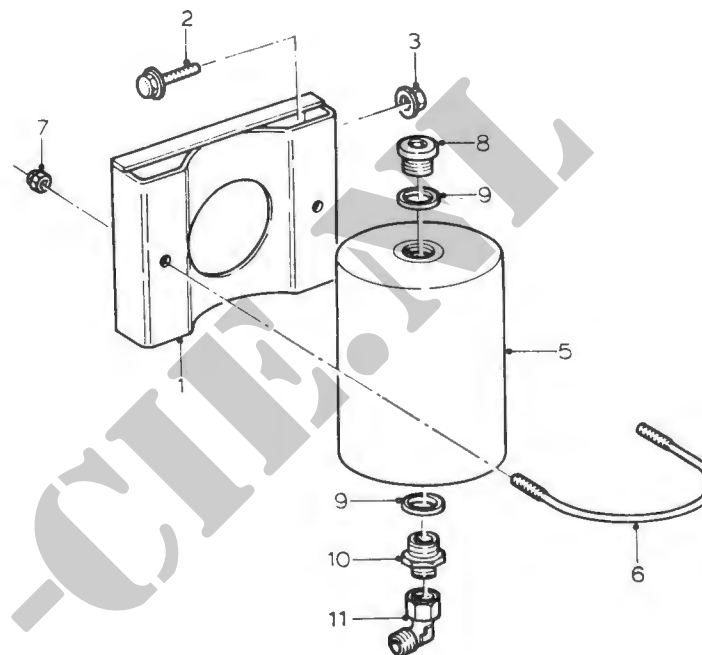
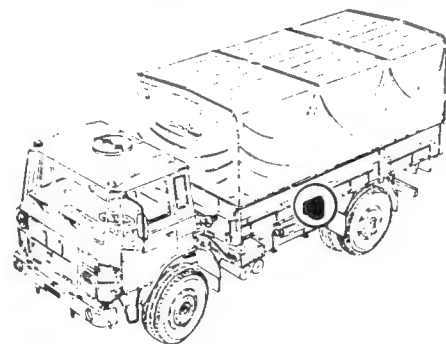

1206-0004

PN 002083

MOSNR 1206-0004

BUFFER RESERVOIR

DATUM: 890905 BLAD: 1

FIGNR	N	MC	B	NSN	C	FCN	REFERENTIENUMMER (= FAN)	ARTIKELOMSCHRIJVING TOELICHTING	AANT ECH	OPMERKINGEN
2			B	5305-17-103-0050	4	H0001	0362030	SCHROEF, ZESKANT KOP	2	2
						D8286	DIN.6921 M8X25X21X18,0X13X8.8			
3			B	5310-17-915-1028	1	H0001	0268985	MOER, FLENS-	2	2
						D8286	DIN.6923 M8X17,9X8X13X8			
7			B	5310-12-167-1881	1	D8286	DIN982-M8-8-A2P	MOER, ZELFBORGEND, ZE	2	2
8			B	5365-17-103-4429	5	H0001	0281264	STOP, CILINDRISCHE S	1	2
9			B	5330-17-015-9817	3	H0001	0147120	PAKKING MET HOUDER	2	2
						H0001	M22X1,5X27,0X2,5DAFN9105			
10			B	0000-KL-041-0688	3	H0001	0369226	KLEMK. MET EPOXYHAR	1	2
11			B	4730-17-101-5455	6	H0001	0285449	KNIE, PYP	1	2

PN 002083

BUFFER RESERVOIR

MOSNR 1206-0004 BLAD: 1

95

-LAATSTE BLAD-

**Y-CHE.ME**

**YCHIE.ME**

PROJECTNUMMER: 002083  
MOSNUMMER : 1401-0001

STUURKOLOM EN STUURWIEL

DATUM 871102  
BLAD 1 VAN 1 BLADEN

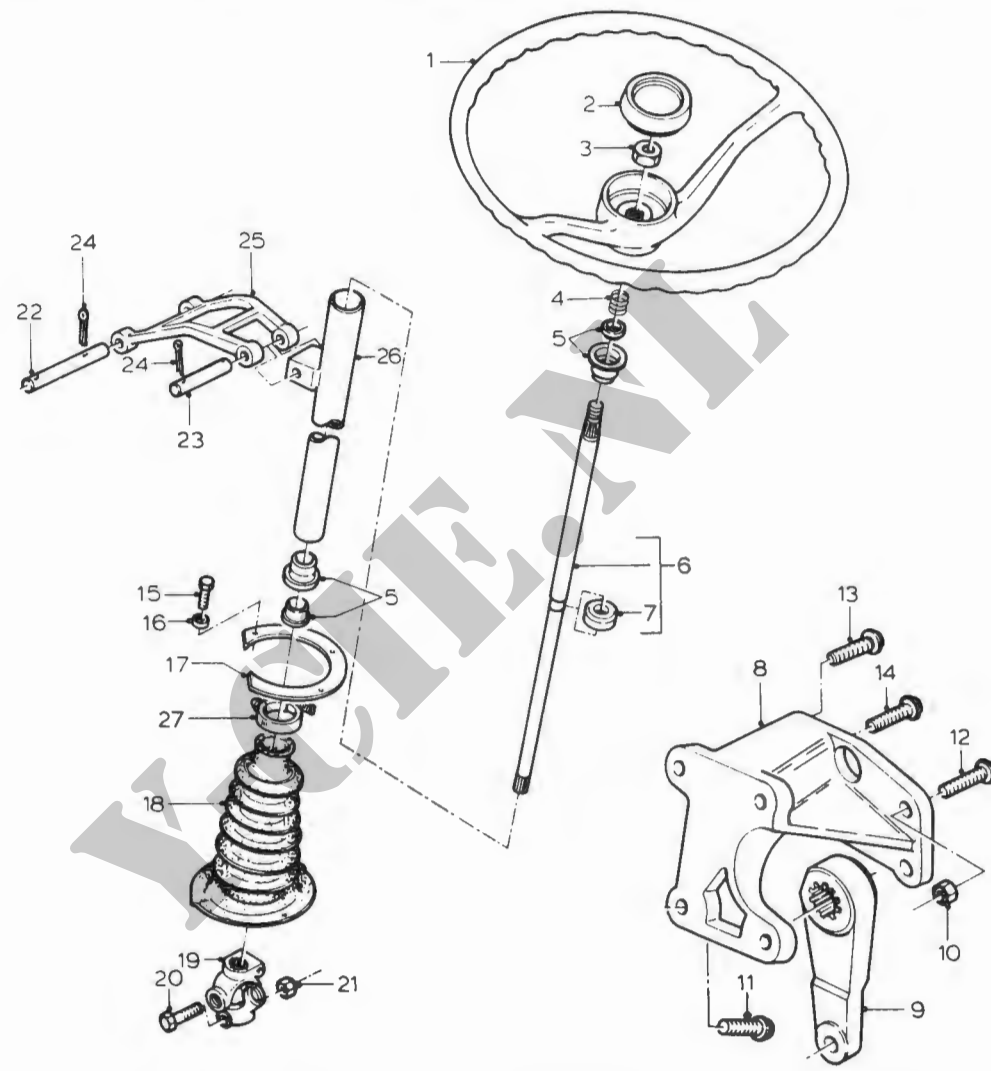
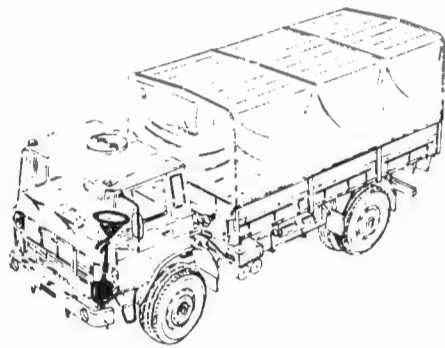

1401-0001

PN 002083

MOSNR 1401-0001

STUURKOLOM EN STUURWIEL

DATUM: 890905 BLAD: 1

FIGNR	N	MC	B	NSN	C	FCN	REFERENTIENUMMER (= FAN)	ARTIKELOMSCHRIJVING TOELICHTING	AANT ECH	OPMERKINGEN
19			B	2520-12-172-7350	8	H0001	0378176	KRUISKOPPELING	1	2
						D0741	7026310302			
20			B	5306-17-102-9685	2	H0001	0369314	BOUT, PAS-	2	2
21			B	5310-12-177-3465	0	D8286	DIN982-M10-8-A2P	MOER, ZELFBORGEND, ZE	2	2
				5310-12-165-1803						DIT NSN IS VERVALLEN BIJ BESTELLING

Y-CHE.ML

PN 002083

STUURKOLOM EN STUURWIEL

MOSNR 1401-0001 BLAD: 1

**YCHIE.ME**

**YCHIE.ME**

PROJECTNUMMER: 002083  
MOSNUMMER : 1401-0002

STUURSTANG

DATUM 871102  
BLAD 1 VAN 1 BLADEN

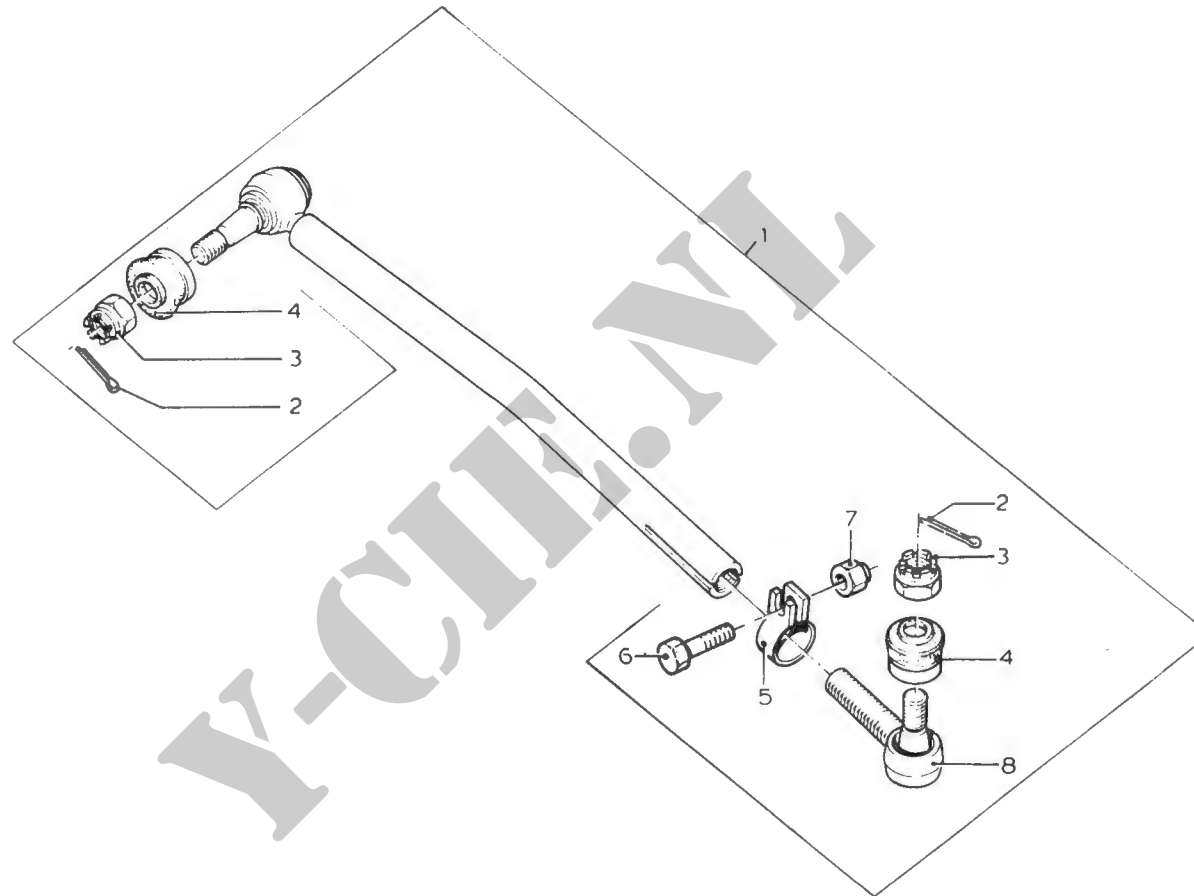
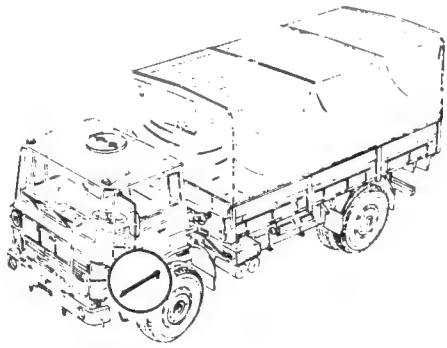

1401-0002

PN 002083

MOSNR 1401-0002

STUURSTANG

DATUM: 890905

BLAD: 1

FIGNR	N	MC	B	NSN	C	FCN	REFERENTIENUMMER (= FAN)	ARTIKELOMSCHRIJVING TOELICHTING	AANT ECH	OPMERKINGEN
1			B	2530-17-910-6850	0	H0001	0391406 D8128 0400231312265	STUURSTANG	1 2	R
2			B	5315-12-197-6054	2	H0001	0251878 D8286 DIN94-5X71-ST-ZNPHR10F	PEN, SPLIT	2 2	
3			B	5310-12-143-2594	8	H0001	0325397 D8286 DIN937-M24X1,5-22H-A2P	MOER, KROON, ZESKANT	1401/0002/00001 2 2	
4			B	2530-12-171-2437	0	H0001	0606924 D8128 0400102554009	BESCHERMHOES, STOF E	1401/0002/00001 2 2	
5			B	5340-17-910-7146	9	H0001	0692587	BEUGEL, KLEM-	1401/0002/00001 1 2	
6			B	5305-12-165-1256	1	H0001	0326375 D8286 DIN960-M12X1,5X65-S-8.8-A3P	SCHROEF, ZESKANTE KO	1401/0002/00001 1 2	
7			B	5310-12-168-7096	3	H0001	0692590 D8286 DIN980-NM12X1,5-8-A2P	MOER, ZELFBORGEND, ZE	1401/0002/00001 1 2	
									1401/0002/00001	

PN 002083

STUURSTANG

MOSNR 1401-0002 BLAD: 1

**YCHIE.ME**

**Y-CHE.ME**

PROJECTNUMMER: 002083

MOSNUMMER : 1401-0003

SPOORSTANG

DATUM 871102

BLAD 1 VAN 1 BLADEN

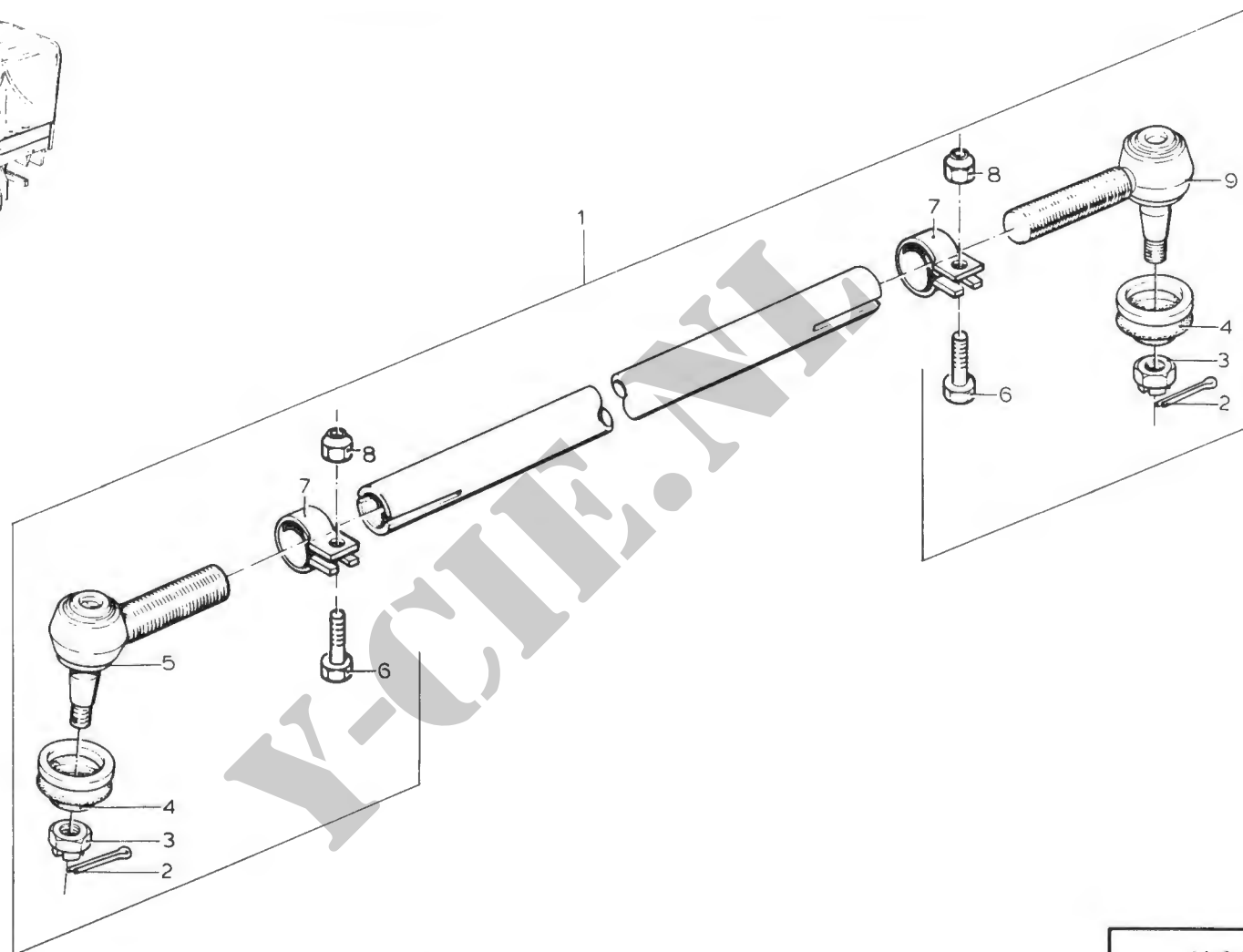
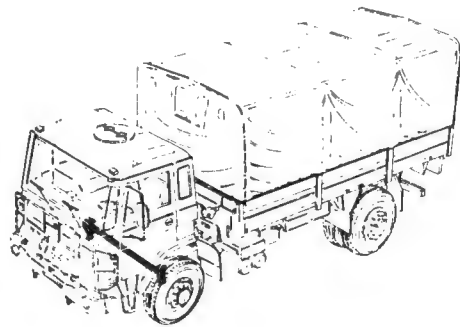

1401-0003

PN 002083

MOSNR 1401-0003

SPOORSTANG

DATUM: 890905 BLAD: 1

FIGNR	N	MC	B	NSN	C	FCN	REFERENTIENUMMER (= FAN)	ARTIKELOMSCHRIJVING TOELICHTING	AANT ECH	OPMERKINGEN
1			B	2530-12-175-1696	0	H0001	0616405	SPOORSTANG	1	2
						D8128	035.5231.041.265			
2			B	5315-17-001-6676	5	H0001	0720714	PEN, SPLIT	2	2
						D8286	DIN94-4X40-ST-ZNPHR10F			1401/0003/00001
3			B	5310-12-144-4726	7	H0001	0124280	MOER, KROON, ZESKANT	2	2
						D8286	DIN937-M20X1,5-22H-A2P			1401/0003/00001
4			B	2530-12-172-0568	2	H0001	0608001	BESCHERMHOES, STOF E	2	2
						D8128	0350102554009			1401/0003/00001
5			B	2530-12-172-1737	5	H0001	0607999	KOGELGEWRIJCHT, ENKEL	1	2
						D8128	4350131543000			1401/0003/00001
6			B	5305-12-165-1256	1	H0001	0326375	SCHROEF, ZESKANTE KO	2	2
						D8286	DIN960-M12X1,5X65-S-8.8-A3P			1401/0003/00001
7			B	5340-17-910-7146	9	H0001	0692587	BEUGEL, KLEM-	2	2
										1401/0003/00001
8			B	5310-17-910-7145	8	H0001	0609534	MOER, ZELFBORGEND	2	2
						D8084	96104190020			1401/0003/00001
9			B	2530-12-172-1735	3	H0001	0607998	KOGELGEWRIJCHT, ENKEL	1	2
						D8128	3350131543000			1401/0003/00001

PN 002083

SPOORSTANG

MOSNR 1401-0003 BLAD: 1

**YCHIE.ME**

**Y-CHE.ME**

PROJECTNUMMER: 002083  
MOSNUMMER : 1403-0002

# HYDRAULISCHE STUURLEIDINGEN

DATUM 871102  
BLAD 1 VAN 1 BLADEN

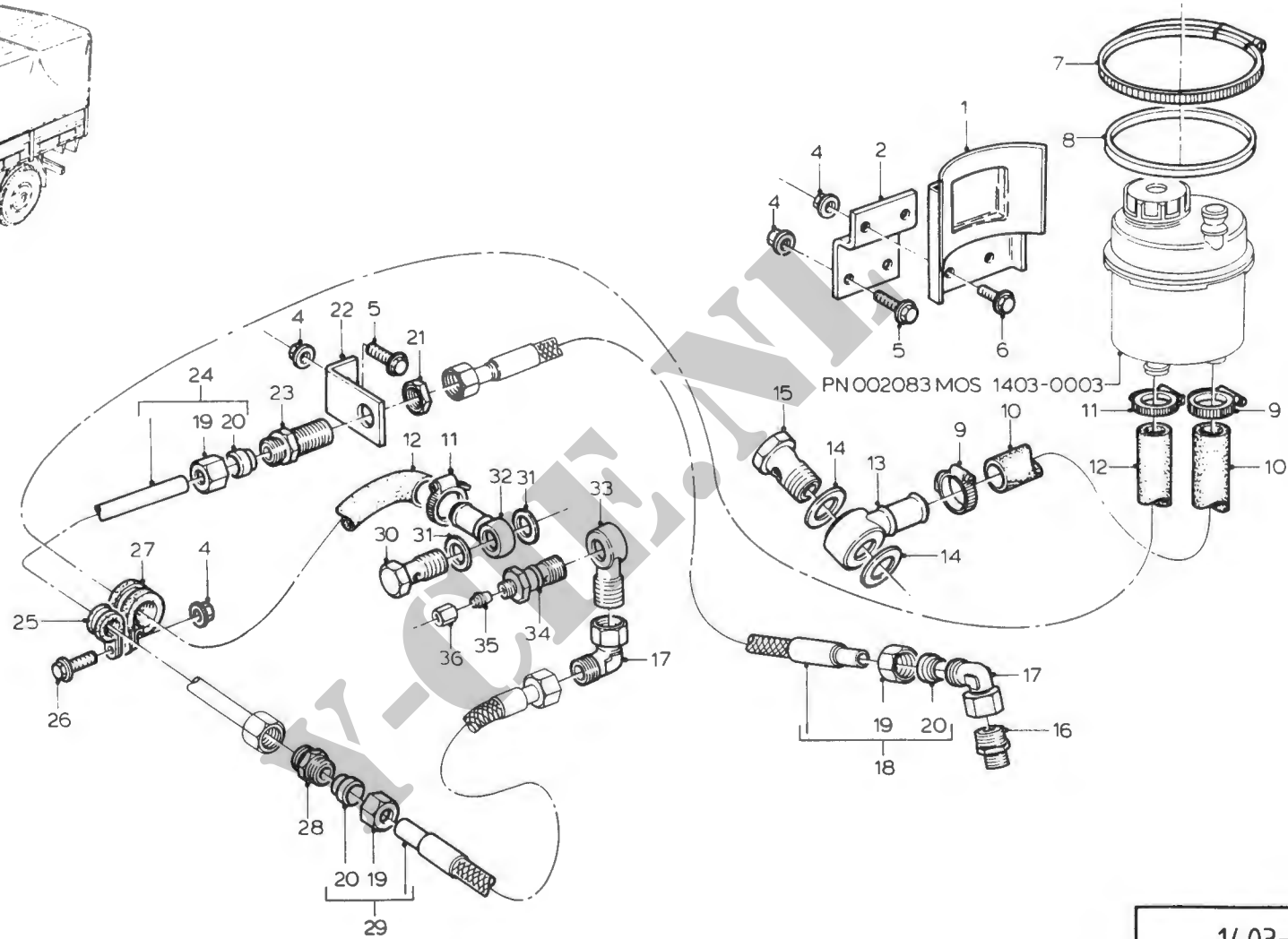
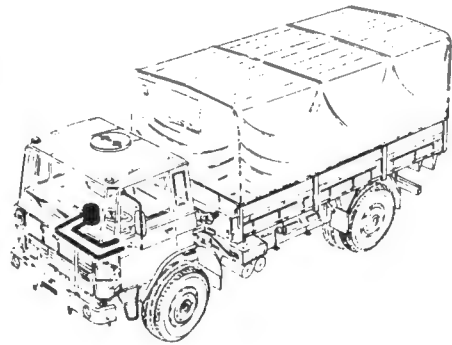

1403-0002

PN 002083

MOSNR 1403-0002

HYDRAULISCHE STUURLEIDINGEN

DATUM: 890905 BLAD: 1

FIGNR	N	MC	B	NSN	C	FCN	REFERENTIENUMMER (= FAN)	ARTIKELOMSCHRIJVING TOELICHTING	AANT ECH	OPMERKINGEN
4			B	5310-17-915-1028	1	H0001	0268985	MOER, FLENS-	7	2
						D8286	DIN.6923 M8X17,9X8X13X8			
5			B	5306-12-317-5568	0	H0001	0268977	BOUT, MACHINE	3	2
						D8286	DIN6921-M8X20-8.8-A2P			
7			B	4730-12-169-4923	9	H0001	0272388	KLEM, SLANG-	2	2
						D8286	DIN3017-AS120-140C8-W2			
9			B	0000-KL-041-0857	7	H0001	0649056	KLEMBAND	2	2
						D8773	SGT20-32 13C7W2			
10			B	4720-17-103-3963	1	H0001	0799098	SLANG, NIET-METAAL	NB	2
11			B	0000-KL-041-0859	9	H0001	0287657	KLEM, SLANG-	2	2
						D8773	SGT16-25 13C7W2			
12			B	4720-17-103-3964	2	H0001	0799099	SLANG, NIET-METAAL	NB	2
13			B	4730-17-103-3965	3	H0001	0361301	AANSLUITSTUK, MEERV	1	2
14			B	5330-12-124-1000	1	H0001	0119135	GASKET	2	2
						D8286	DIN7603-A26X32-CU			
15			B	0000-KL-041-0743	3	H0001	0202535	BOUT, BANJO-	1	2
						D8286	DIN7623-DXM26X1,5X20X13,5			
16			B	4730-12-132-1913	9	H0001	0615916	AANPASSTUK, RECHT, PY	1	2
						H0001	M18X1,5XLX15XM22X1,5DAFN.9122			
17			B	4730-17-055-2436	0	H0001	0118243	KNIFE, PYP	2	2
						H0001	15X15XLXM22X1,5XM22X1,5DAF9130			
18			B	4720-17-103-3966	4	H0001	0222613	SLANGSAMENSTEL, GEL	1	2
19			B	4730-12-132-1910	6	H0001	0719243	MOER, PYPKOPPELING	6	2
						D8286	DIN3870-AL15			
20			B	4730-12-131-3696	9	H0001	0226481	HULS, INPERS-, PYPFIT	6	2
						D8286	DIN3861-L15-ST-A3P			
21			B	5310-12-144-4041	4	H0001	0226492	MOER, ZESKANT	1	2
23			B	4730-12-143-0125	3	H0001	0179920	NIPPEL, PYP	1	2
						H0001	15X15XLXM22X1,5XM22X1,5DAF9121			
25			B	5340-12-159-4283	8	H0001	0610734	KLEM, LUS	2	2
						D8286	DIN3016-D1-15X20-W1-2			
26			B	5305-17-103-0050	4	H0001	0362030	SCHROEF, ZESKANT KOP	2	2
						D8286	DIN.6921 M8X25X21X18,0X13X8.8			
27			B	5340-12-199-8969	4	H0001	0116596	KLEM, LUS	2	2
						D8286	DIN3016-D1-25X20-W1-2			
28			B	4730-17-101-4440	3	H0001	0265681	NIPPEL, PYP	1	2
						H0001	15X15XLXM22X1,5XM22X1,5DAF9120			
29			B	4720-17-103-3967	5	H0001	0291237	SLANGSAMENSTEL, GEL	1	2
30			B	4730-12-124-4656	5	H0001	0325458	BOUT, BANJO	1	2
						D8286	DIN7623-A13			
31			B	5330-12-156-4527	7	H0001	0331331	GASKET	2	2
						D8286	DIN7603-A18X24-CU			

PN 002083

HYDRAULISCHE STUURLEIDINGEN

MOSNR 1403-0002 BLAD: 1

**YCHIE.ME**

PN 002083

MOSNR 1403-0002

HYDRAULISCHE STUURLEIDINGEN

DATUM: 890905 BLAD: 2

FIGNR	N	MC	B	NSN	C	FCN	REFRENTIENUMMER (= FAN)	ARTIKELOMSCHRIJVING TOELICHTING	AANT ECH	OPMERKINGEN
32			B	4730-17-103-3737	6	H0001	0372830	AANSLUITSTUK, MEERV	1 2	
33			B	0000-KL-041-0867	6	H0001	0618042	HUIS, BANJO-	1 2	
						D8134	XSWVE 15LM			
34			B	0000-KL-041-0868	7	H0001	0366035	BOUT, BANJO-	1 2	
						D8134	HS M18X1,5/SA10/A3C			
35			B	2815-17-103-3968	6	H0001	0294228	PROP, CONISCH	1 2	
36			B	4730-12-132-5661	6	H0001	0226483	MOER, PYPKOPPELING	1 2	
						D8286	DIN3870-AL6			

KCH.MB

PN 002083

HYDRAULISCHE STUURLEIDINGEN

MOSNR 1403-0002 BLAD: 2

100

-LAATSTE BLAD-

**YCHIE.ME**

**YCHIE.ME**

PROJECTNUMMER: 002083  
MOSNUMMER : 1403-0003

HYDR. STUURPOMPTANK

DATUM 871102  
BLAD 1 VAN 1 BLADEN

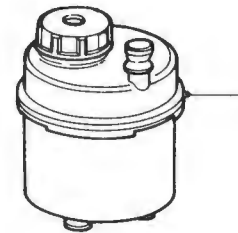
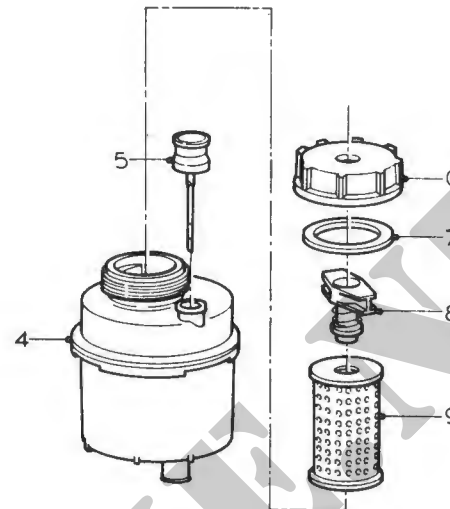
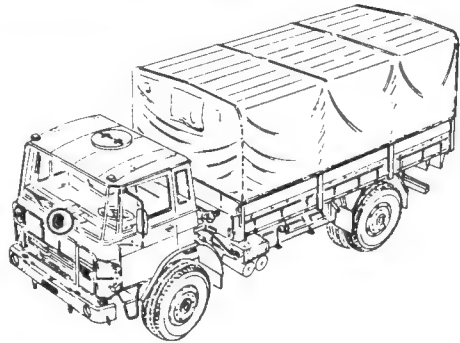

1403-0003

PN 002083

MOSNR 1403-0003

HYDR. STUURPOMPTANK

DATUM: 890905 BLAD: 1

FIGNR N MC B NSN C FCN REFERENTIENUMMER (= FAN)

ARTIKELOMSCHRIJVING TOELICHTING AANT ECH OPMERKINGEN

9 B 2940-12-166-3602 5 H0001 0229348  
D8086 6730253196

FILTER ELEMENT, FLUI 1 2

Y-CHE.ML

PN 002083

HYDR. STUURPOMPTANK

MOSNR 1403-0003 BLAD: 1

101

-LAATSTE BLAD-

**Y-CHE.ME**

**YCHIE.ME**

PROJECTNUMMER: 002083  
MOSNUMMER : 1802-0005

# PORTIEREN

DATUM 871102  
BLAD 1 VAN 1 BLADEN

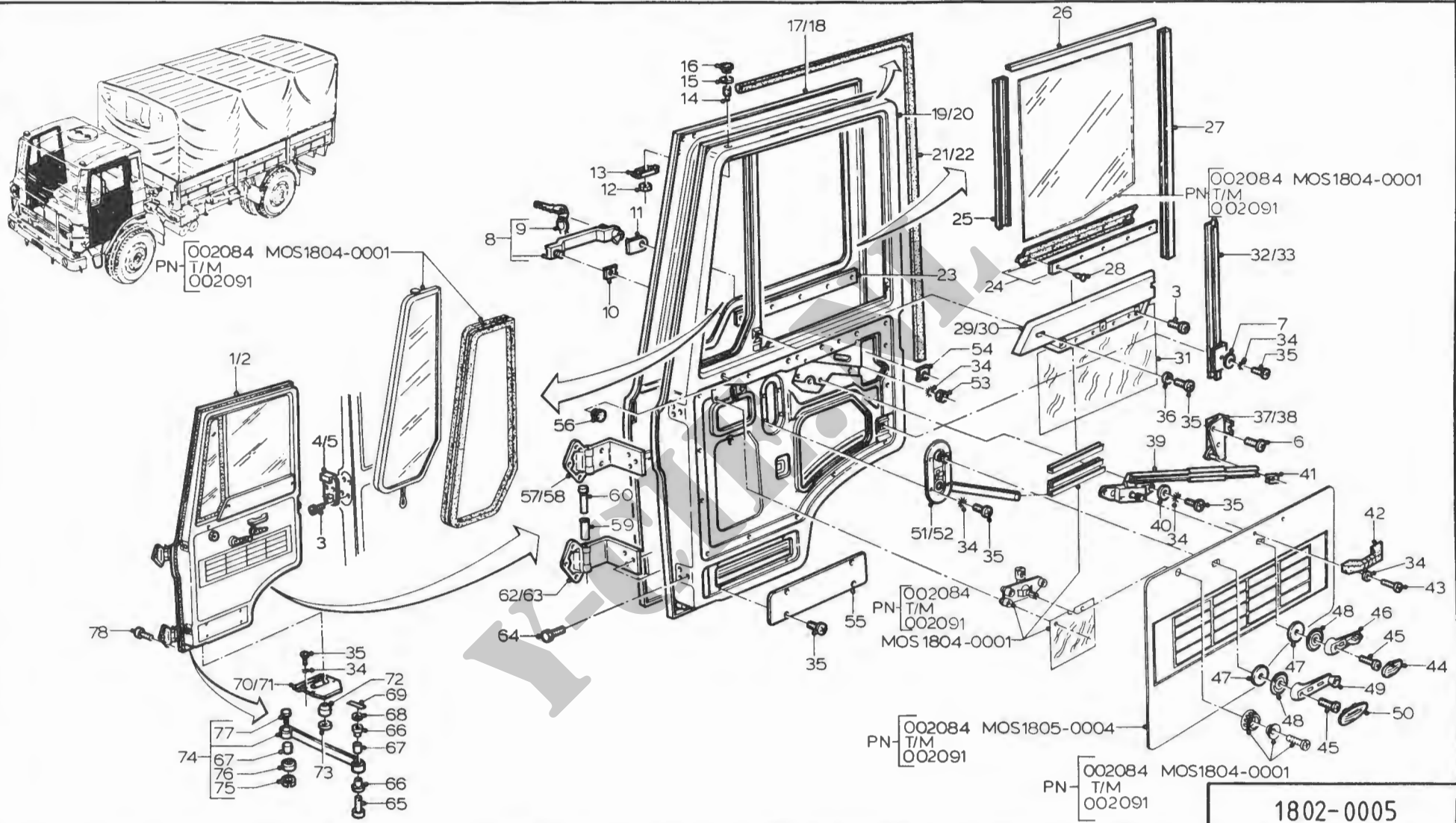

PN 002083

MOSNR 1802-0005

PORTIEREN

DATUM: 890905

BLAD: 1

FIGNR	N MC	B	NSN	C	FCN	REFERENTIENUMMER (= FAN)	ARTIKELOMSCHRIJVING	TOELICHTING	AANT ECH	OPMERKINGEN
3		B	5305-12-167-5871	9	D8286	DIN966-M6X12-4.8-H	SCHROEF, MACHINE		8 2	
4		B	5340-17-049-7831	9	H0001	0622005	SLUITPLAAT, SLOT	LINKS	1 2	
5		B	5340-17-049-7830	8	H0001	0622006	SLUITPLAAT, SLOT	RECHTS	1 2	
8		B	2540-12-177-7781	4	H0001	0629979	GRIFBAGGRUPPE, TUE		2 2	
					D0883	00-392-0000				
9		B	2540-17-102-0310	0	H0001	0696119	SLEUTEL, DEUR		2 2	
										1802/0005/00008
10		B	5310-17-049-7864	9	H0001	0501418	ONDERLEGRING, VLAK		2 2	
11		B	5330-17-049-7834	1	H0001	0597681	GASKET		2 2	
13		B	5340-17-049-7921	0	H0001	0331447	MOERHOUDER		2 2	
14		B	5305-17-049-7923	2	H0001	0501820	STELSCHROEF		2 2	
15		B	5310-12-144-6214	0	H0001	0251275	MOER, ZESKANT		2 2	
					D8286	DIN934-M8-8-A2P				
21		B	5330-17-049-9042	0	H0001	0597709	AFDICHTING, RUBBER S		1 2	
22		B	5330-17-049-9043	0	H0001	0597710	AFDICHTING, RUBBER S		1 2	
35		B	5305-12-142-5568	0	H0001	0521832	SCHROEF, MACHINE		34 2	
					D8286	DIN7985-M6X12-4.8-H-A2P				
36		B	5310-12-142-0644	4	D8286	DIN125-B6, 4-ST-A3P	ONDERLEGRING, VLAK		8 2	
37		B	5340-12-192-4173	8	H0001	0622003	SLOT, INLATEND	LINKS	1 2	
					C1583	1497 LS				
38		B	5340-17-049-7656	0	H0001	0622004	PORTIERSLOT	RECHTS	1 2	
					C1583	1496				
39		B	5340-17-050-6519	7	H0001	0597505	BEDIENINGSSTANG		2 2	
					D0883	016952				
40		B	5310-12-142-0644	4	D8286	DIN125-B6, 4-ST-A3P	ONDERLEGRING, VLAK		4 2	
41		B	5340-12-177-4346	1	H0001	0559346	KLEM, VEER-		2 2	
					D9414	6SXN08				
42		B	5340-17-049-7828	6	H0001	0597758	HANDGREEP, VAST		2 2	
43		B	5305-12-142-5576	8	H0001	0318918	SCHROEF, MACHINE		4 2	
					D8286	DIN7985-M6X20-4.8-H-A2P				
44		B	2540-12-176-6605	4	H0001	0597771	DECKPLATTE		2 2	
					C1727	045-114-00-0				
45		B	0000-KL-041-0870	9	H0001	0124018	SCHROEF		2 2	
					D8286	DIN966-M5X12X7,5				
46		B	2540-17-049-7068	5	H0001	0512605	DEURKRUK		2 2	
47		B	5330-12-124-4409	0	H0001	0226488	GASKET		4 2	
					D8286	DIN7603-A12X18-VF				
48		B	5340-17-049-7744	0	H0001	0621989	ROZET		4 2	
49		B	2540-17-915-1377	9	H0001	0679028	KRUK, RAAMMECHANISME		2 2	
50		B	2540-12-176-6606	5	H0001	0597773	DECKPLATTE		2 2	
					C1727	045-116-00-0				

PN 002083

PORTIEREN

MOSNR 1802-0005 BLAD:

1

FIGNR	N	MC	B	NSN	C	FCN	REFERENTIENUMMER (= FAN)	ARTIKELOMSCHRIJVING	TOELICHTING	AANT	ECH	OPMERKINGEN
55			B	5340-17-049-8621	7	H0001	0512610	SCHOPPLAAT, DEUR		2	2	
56			B	5325-17-043-9746	4	H0001	0539318	TULE, RUBBER		2	2	
57			B	0000-KL-041-0871	0	H0001	0539868	SCHARNIER	LINKS	1	2	
58			B	0000-KL-041-0872	0	H0001	0539869	SCHARNIER	RECHTS	1	2	
59			B	5340-12-318-0219	8	H0001	0067787	BRACKET, MOUNTING		4	2	**
						D0491	63796					
60			B	5340-12-318-0220	9	H0001	0067788	TORSIESTAAF, SCHARN		4	2	**
						D0491	66877					
62			B	5340-12-318-1379	2	H0001	0539866	SCHARNIER (1), DEUR	LINKS	1	2	**
63			B	5340-12-318-0218	7	H0001	0539867	SCHARNIER (1), DEUR	RECHTS	1	2	**
64			B	5305-17-103-0050	4	H0001	0362030	SCHROEF, ZESKANT KOP		12	2	
						D8286	DIN6921-M8X25-8.8-A2P					
65			B	5315-17-103-3739	8	H0001	0398911	PEN, GEGROEFD, MET		2	2	
66			B	3120-17-049-9221	2	H0001	0573647	LAGER, BUS		4	2	
67			B	3120-17-049-7919	9	H0001	0331428	LAGER, BUS		4	2	
68			B	5310-17-101-7429	0	H0001	0251916	ONDERLEGRING, VLAK		2	2	R
69			B	0000-KL-041-0875	3	H0001	0398811	SPLITPEN		2	2	
						D9414	12X4SXN55					
70			B	2540-17-049-7843	0	H0001	0596225	GELEIDINGSPLAAT, DEU		2	2	
71			B	2540-17-049-7842	9	H0001	0596301	GELEIDINGSPLAAT, DEU		2	2	
72			B	3120-17-049-7914	4	H0001	0331425	LAGER, BUS		4	2	
73			B	5310-12-156-4899	5	H0001	0202950	ONDERLEGRING, VLAK		2	2	
						D8286	DIN125-B13-ST-A3P					
74			B	5360-17-103-3969	7	H0001	0597536	VEER (1), BLAD		2	2	
75			B	5365-12-156-4445	2	H0001	0251977	RING, BORG-, VEREND		2	2	
						D8286	DIN471-12X1					
76			B	2540-17-049-7872	6	H0001	0331430	LOOPROL, DEURUITSTEL		4	2	
77			B	5315-17-049-7915	5	H0001	0613152	PEN, GEGROEFD, MET KO		2	2	
78			B	5306-17-102-9686	3	H0001	0673433	BOUT, INWENDIG AAN		12	2	

**Y-CHE.ME**

PROJECTNUMMER: 002083  
MOSNUMMER : 1802-0006

GRILLE

DATUM 871102  
BLAD 1 VAN 1 BLADEN

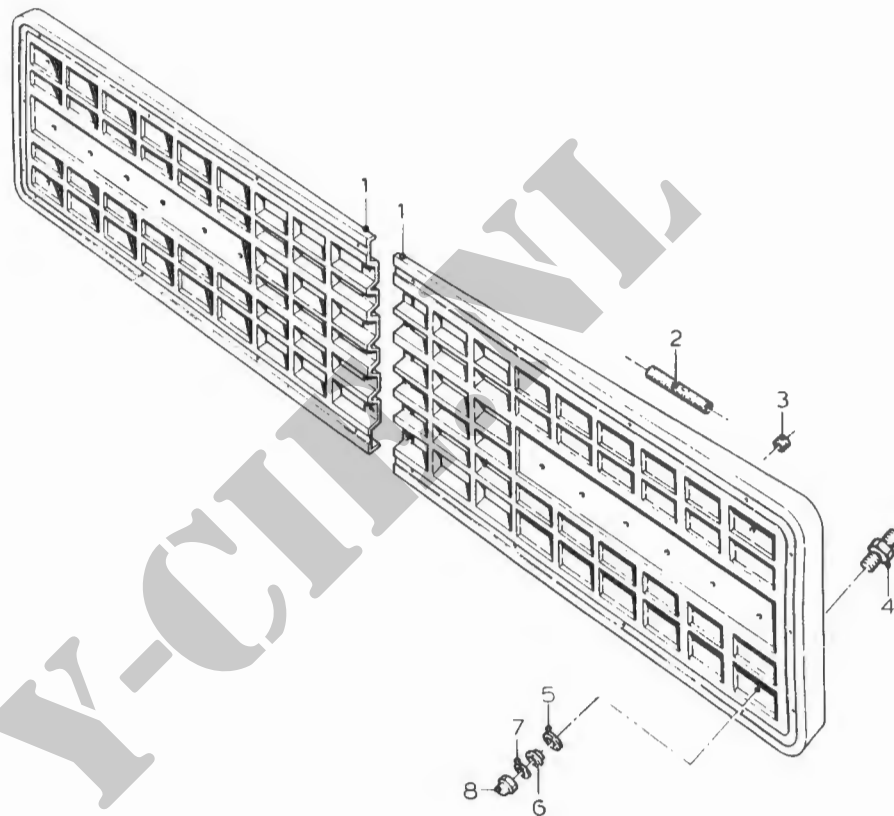
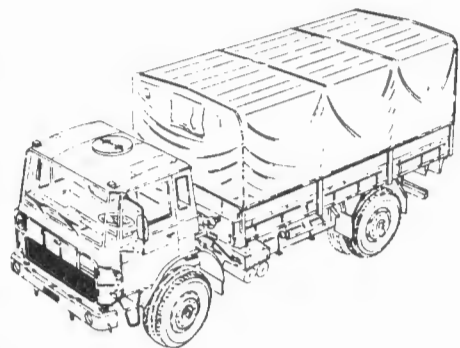

1802-0006

PN 002083

MOSNR 1802-0006

GRILLE

DATUM: 890905 BLAD: 1

FIGNR	N	MC	B	NSN	C	FCN	REFERENTIENUMMER (= FAN)	ARTIKELOMSCHRIJVING TOELICHTING	AANT	ECH	OPMERKINGEN
1			B	2510-17-103-3738	7	H0001	0670806	GRILLE, KUNSTSTOF	2	2	
2			B	4720-17-103-3970	8	H0001	0633776	SLANG, NIET-METAAL	2	2	
3			B	5340-17-103-3971	9	H0001	0632705	BUFFER, RUBBER	12	2	
4			B	5307-17-103-3972	0	H0001	0597386	TAPEIND, BORST	8	2	
5			B	5330-17-103-3973	0	H0001	0597387	PAKKING, VOORGEVORM	8	2	
6			B	3120-17-103-3899	3	H0001	0264942	LAGER, BUS	8	2	
7			B	5310-17-103-3974	1	H0001	0264941	ONDERLEGRING (1), V	8	2	
8			B	5310-17-103-3975	2	H0001	0506348	MOER (1), DOP	8	2	

PN 002083

GRILLE

MOSNR 1802-0006 BLAD: 1

104

-LAATSTE BLAD-

**YCHIE.ME**

**YCHIE.ME**

PROJECTNUMMER: 002083  
MOSNUMMER : 1803-0002

SPATSCHERMEN ACHTER

DATUM 871102  
BLAD 1 VAN 1 BLADEN

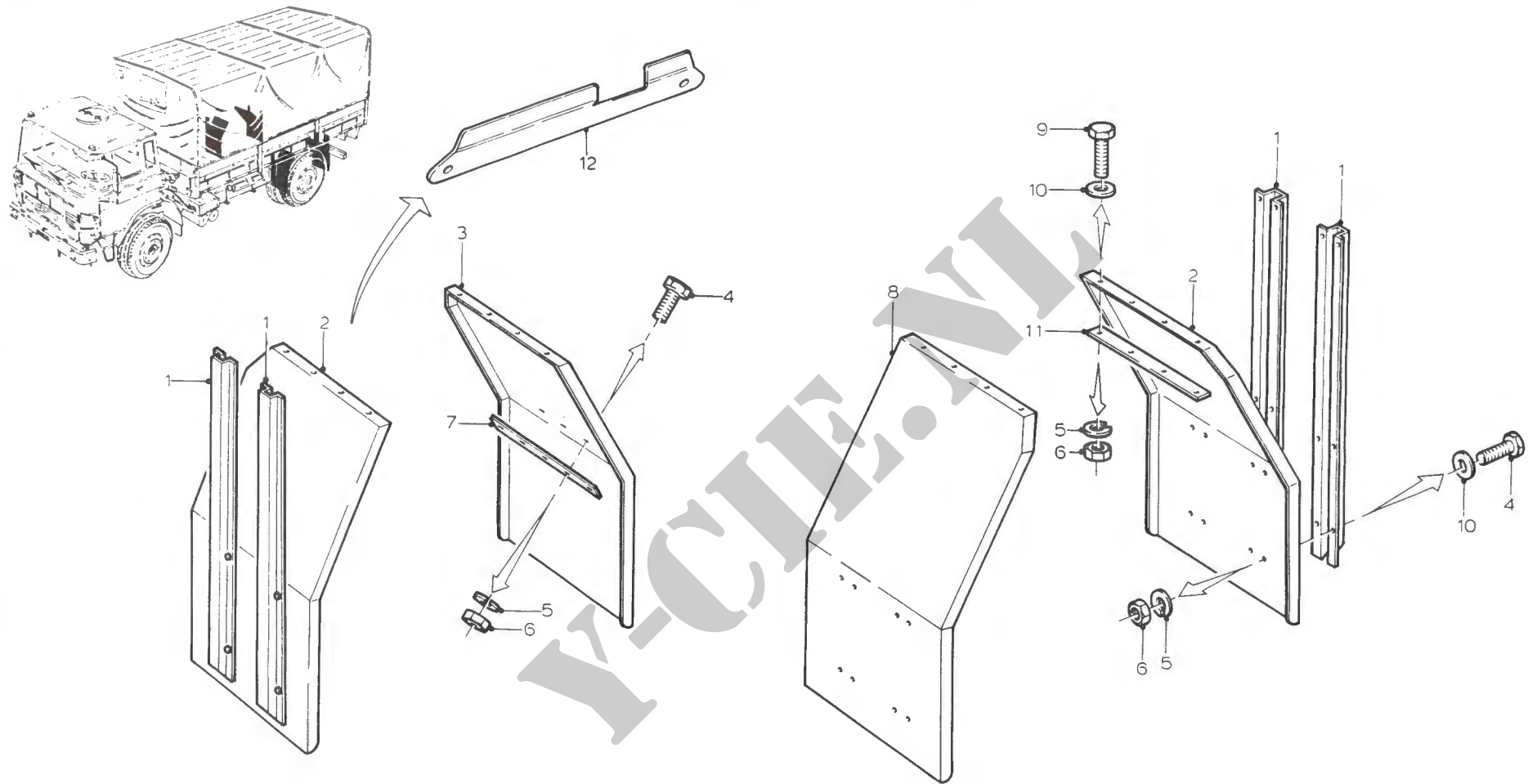

1803-0002

PN 002083

MOSNR 1803-0002

SPATSCHERMEN ACHTER

DATUM: 890905 BLAD: 1

FIGNR	N MC	B	NSN	C	FCN	REFERENTIENUMMER (= FAN)	ARTIKELOMSCHRIJVING TOELICHTING	AANT ECH	OPMERKINGEN
1		B	2510-17-103-3980	7	H0001	0824987	STEUN, SPATSCHERM	8 2	
2		B	2540-17-103-4055	5	H0001	0840562	SPATSCHERM, VOERTUIG	2 2	
3		B	2540-17-103-4056	6	H0001	0840564	SPATSCHERM, VOERTUIG	1 2	
4		B	5305-12-156-4861	0	D8286	DIN933-M6X25-8.8-A2P	SCHROEF, ZESKANTE KO	53 2	
					H0001	0251614			
5		B	5310-12-162-2129	2	H0001	0251927	ONDERLEGRING, BORG-	53 2	
					D8286	DIN128-A6-FST			
6		B	5310-12-156-4991	9	H0001	0251274	MOER, ZESKANT	69 2	
					D8286	DIN934-M6-8-A2P			
7		B	2510-17-050-7939	8	H0001	0821996	STRIP	1 2	
8		B	2540-17-103-4057	7	H0001	0840563	SPATSCHERM, VOERTUIG	1 2	
9		B	5305-12-146-2633	6	H0001	0126718	SCHROEF, ZESKANTE KO	22 2	
					D8286	DIN933-M6X16-8.8-A2P			
10		B	5310-12-142-0644	4	D8286	DIN125-B6,4-ST-A3P	ONDERLEGRING, VLAK	64 2	
11		B	5340-17-103-3979	6	H0001	0824988	STRIP, BEVESTIGING	2 2	
12		B	0000-KL-044-0801	9	H0001	0840105	STRIP, BEVESTIGINGS- LINKS	1 2	
12A		B	0000-KL-044-0802	0	H0001	0840106	STRIP, BEVESTIGINGS- RECHTS	1 2	

PN 002083

SPATSCHERMEN ACHTER

MOSNR 1803-0002 BLAD: 1

105

-LAATSTE BLAD-

**Y-CHE.ME**

**Y-CHE.ME**

PROJECTNUMMER: 002083  
MOSNUMMER : 1805-0001

STOEL BESTUURDER

DATUM 871102  
BLAD 1 VAN 2 BLADEN

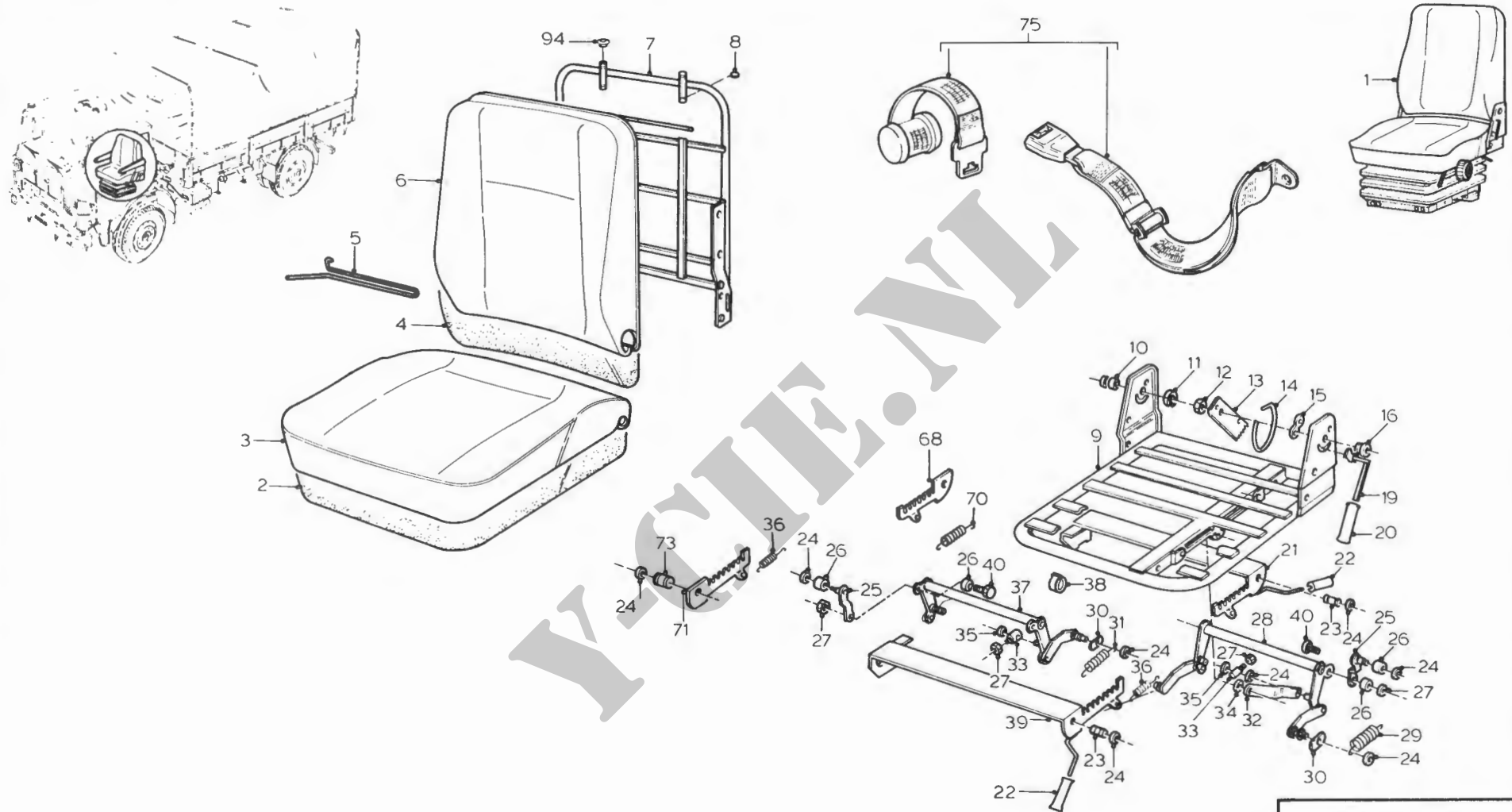

1805-0001

**YCHIE.ME**

PROJECTNUMMER: 002083  
MOSNUMMER : 1805-0001

STOEL BESTUURDER

DATUM 871102  
BLAD 2 VAN 2 BLADEN

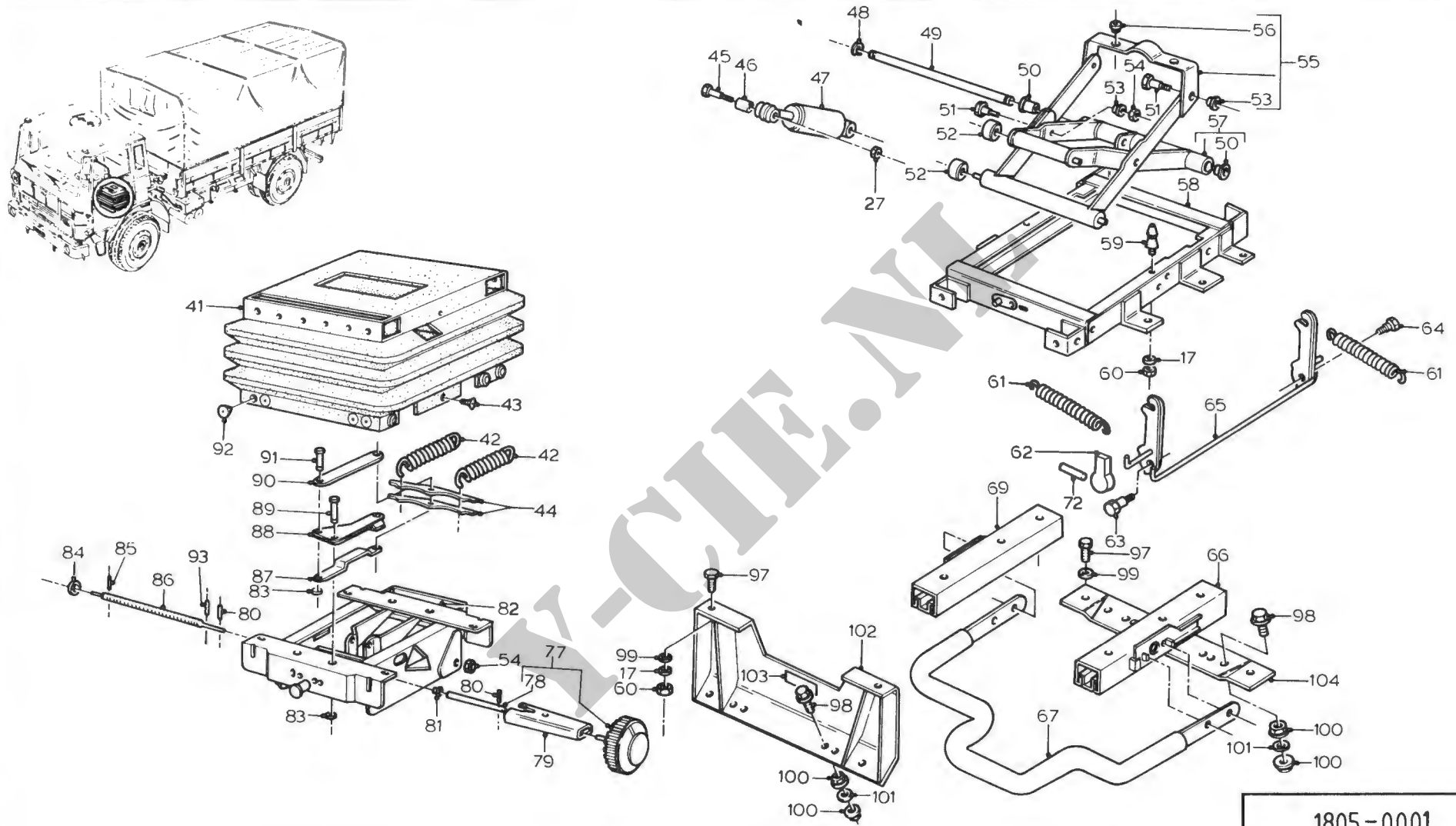

1805-0001

PN 002083

MOSNR 1805-0001

STOEL, BESTUURDER

DATUM: 890905 BLAD: 1

FIGNR	N	MC	B	NSN	C	FCN	REFERENTIENUMMER (= FAN)	ARTIKELOMSCHRIJVING TOELICHTING	AANT	ECH	OPMERKINGEN
10			B	0000-KL-041-1069	0	H0001	0698733	BUS, LAGER-	1	2	
						D8173	40222				
11			B	0000-KL-041-1070	0	H0001	0698732	RING, BORG-	1	2	
						D8173	60042				
12			B	5310-17-034-0954	3	H0001	0243806	MOER, ZESKANT	1	2	
13			B	0000-KL-046-5875	3	H0001	0068962	PLAAT, AFSTEL-	1	2	
						D8173	40843 X				
16			B	0000-KL-041-1074	4	H0001	0698728	BUS, LAGER-	1	2	
						D8173	40874				
19			B	0000-KL-046-5876	4	H0001	0066076	HANDEL, BEDIENINGS-	1	2	
						D8173	44367				
20			B	0000-KL-046-5906	1	H0001	0066075	KNOP	1	2	
						D8173	4022401				
22			B	0000-KL-046-5905	0	H0001	0066072	KNOP	2	2	
						D8173	4059801				

PN 002083

STOEL, BESTUURDER

MOSNR 1805-0001 BLAD: 1

106

-LAATSTE BLAD-

**YCHIE.ME**

**YCHIE.ME**

PROJECTNUMMER: 002083  
MOSNUMMER : 1805-0007

AFDEKMIDDELEN

DATUM 871102  
BLAD 1 VAN 1 BLADEN

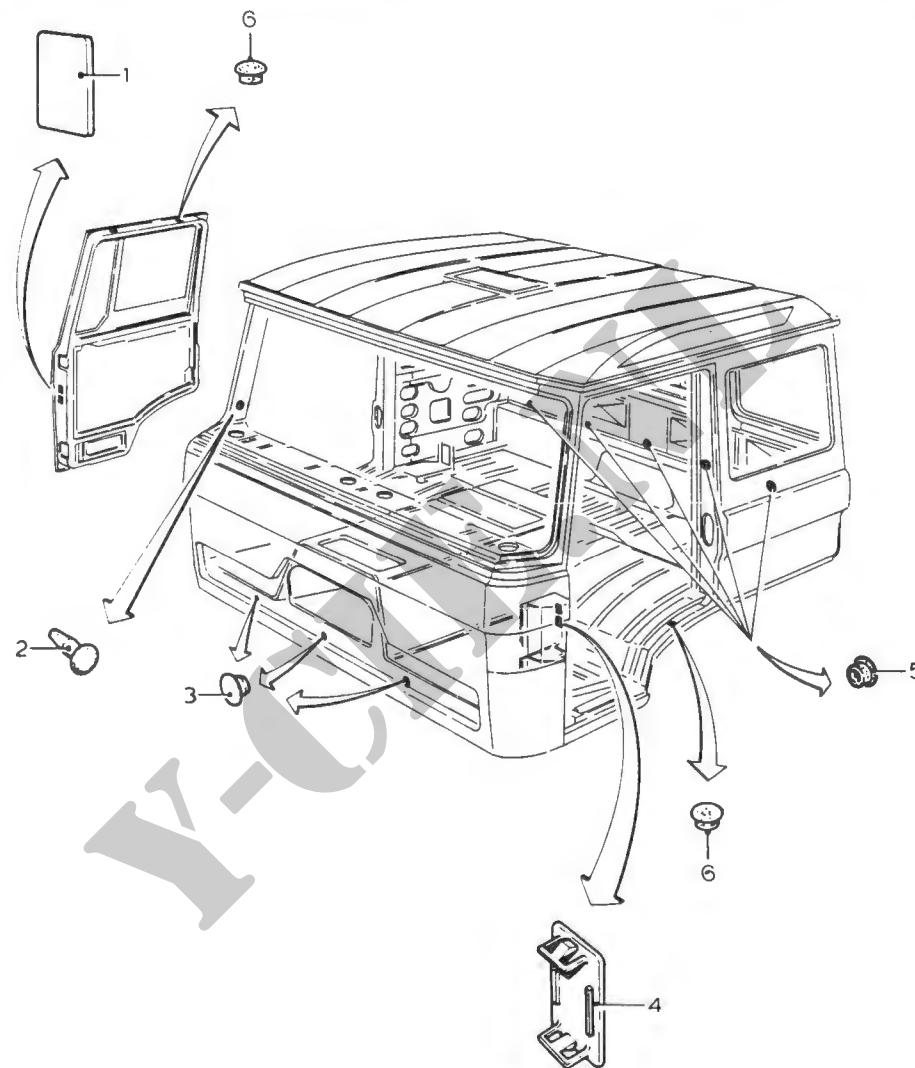

1805-0007

PN 002083

MOSNR 1805-0007

AFDEKMIDDELEN

DATUM: 890905

BLAD: 1

FIGNR	N	MC	B	NSN	C	FCN	REFERENTIENUMMER (= FAN)	ARTIKELOMSCHRIJVING	TOELICHTING	AANT	ECH	OPMERKINGEN
1			B	2540-17-102-9697	3	H0001	0656225	AFDEKKING, BINNENPLA		NB	2	
2			B	5325-12-181-3975	8	H0001	0593328	SIERKNOOPSLUITING		NB	2	
						C0300	254-0130-000					
3			B	5340-12-300-0116	8	H0001	0633023	STOP, BESCHERM-, STOF		NB	2	
						D8794	12611					
4			B	2540-17-102-9698	4	H0001	0656226	AFDEKKING, BINNENPL		NB	2	
5			B	2590-17-907-1025	1	H0001	0662611	TECTIELDOPJE		NB	2	
						D8794	0521475					
6			B	0000-KL-041-0890	7	H0001	0369485	STOP		NB	2	
						D8794	12774 PE181S					

KCH.ML

PN 002083

AFDEKMIDDELEN

MOSNR 1805-0007 BLAD: 1

-LAATSTE BLAD-

**Y-CHE.ME**

**YCHIE.ME**

PROJECTNUMMER: 002083  
MOSNUMMER : 1805-0008

CENTRAALKAST IN KABINE

DATUM 871102  
BLAD 1 VAN 1 BLADEN

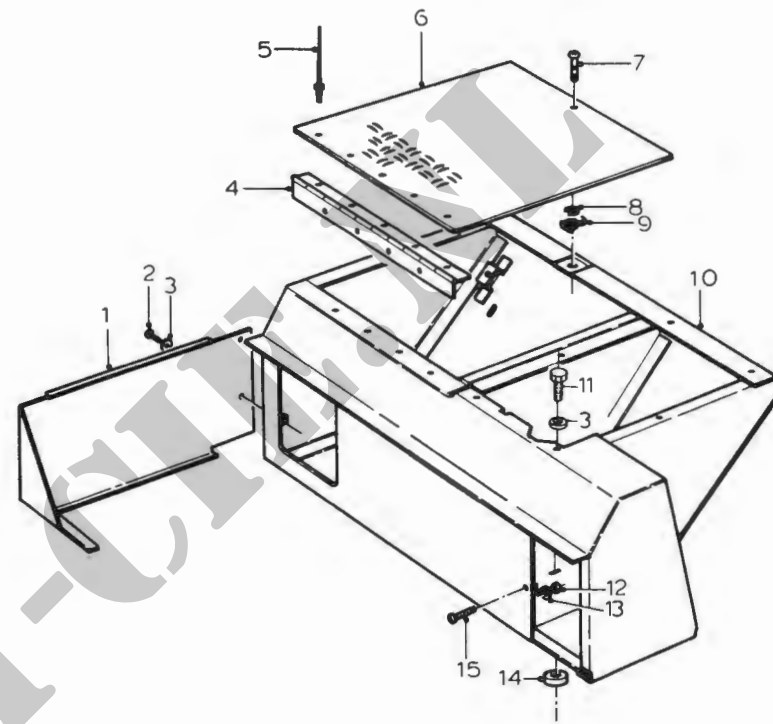

1805-0008

PN 002083

MOSNR 1805-0008

INTERIEUR

DATUM: 890905

BLAD: 1

FIGNR	N	MC	B	NSN	C	FCN	REFERENTIENUMMER (= FAN)	ARTIKELOMSCHRIJVING TOELICHTING	AANT ECH	OPMERKINGEN
7			B	0000-KL-041-0896	2	H0001	0667245	KERFSTIFT	1 2	
8			B	0000-KL-041-0897	3	H0001	0667247	PLAAT, AFSTEL-BR. POM	1 2	
9			B	5340-17-915-1232	7	H0001	0667246	LOCK, QUICK, ACTION	1 2	

Y-CHE.ML

PN 002083

INTERIEUR

MOSNR 1805-0008

BLAD: 1

108

-LAATSTE BLAD-

**Y-CHE.ME**

Y-CHE.ME

PROJECTNUMMER: 002083

MOSNUMMER : 1807-0001

OPBERGKAST DEKZEIL

DATUM 871102

BLAD 1 VAN 1 BLADEN

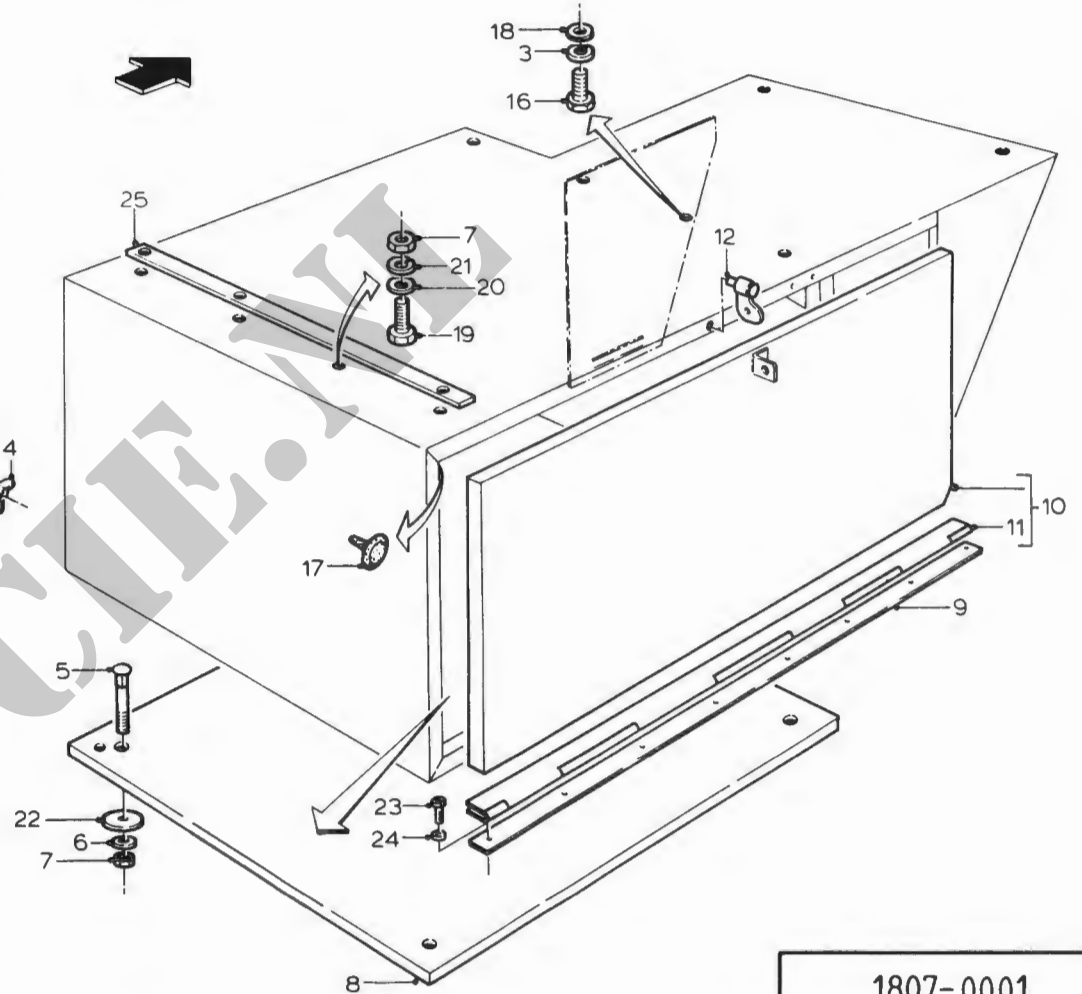
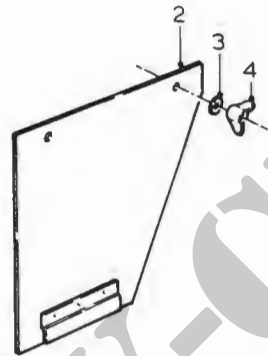
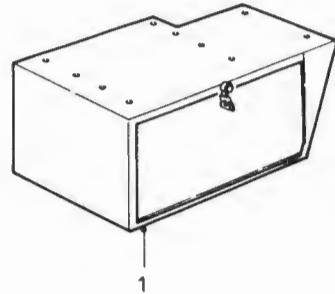
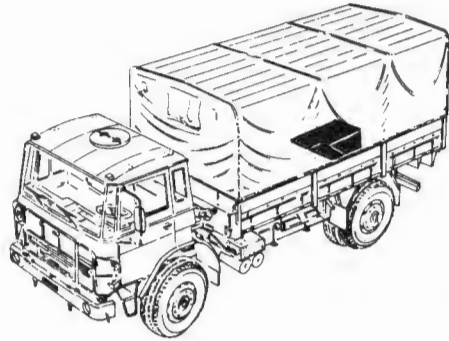

1807-0001

PN 002083

MOSNR 1807-0001

OPBERGKAST DEKZEIL

DATUM: 890905

BLAD: 1

FIGNR	N MC	B	NSN	C	FCN	REFERENTIENUMMER (= FAN)	ARTIKELOMSCHRIJVING TOELICHTING	AANT ECH	OPMERKINGEN
1		B	2540-17-103-4054	4	H0001	0840541	KAST VOOR ZEILWERK	1 2	
3		B	5310-12-162-2129	2	H0001	0251927	ONDERLEGRING, BORG-	6 2	
					D8286	DIN128-A6-FST			
4		B	5310-12-143-1187	9	H0001	0251379	MOER, VLEUGEL	2 2	
					D8286	DIN315-M6-5-B-A2P			
5		B	0000-KL-041-0900	6	H0001	0574960	BOUT, SLOT-	4 2	
6		B	5310-12-142-0645	5	H0001	0251905	ONDERLEGRING, VLAK	4 2	
7		B	5310-12-144-6214	0	H0001	0251275	MOER, ZESKANT	4 2	
					D8286	DIN934-M8-8-A2P			
9		B	5340-17-049-9435	7	H0001	0821953	MONTAGESTRIP, SCHARN	1 2	
11		B	5340-17-049-9098	0	H0001	0821957	SCHARNIER, DEUR	1 2	
									1807/0001/00010
12		B	5340-17-049-3692	6	H0001	0819559	KNEVEL MET TOEBEHOR	1 2	
16		B	5305-12-156-4861	0	H0001	0251614	SCHROEF, ZESKANTE KO	4 2	
					D8286	DIN933-M6X25-8.8-A2P			
17		B	5340-17-022-3322	5	H0001	0193675	BUFFER, RUBBER	2 2	
18		B	5310-12-142-0644	4	D8286	DIN125-B6,4-ST-A3P	ONDERLEGRING, VLAK	4 2	
19		B	5305-12-156-4863	2	H0001	0251621	SCHROEF, ZESKANTE KO	6 2	
					D8286	DIN933-M8X20-8.8-A2P			
20		B	5310-12-149-4353	2	H0001	0325421	ONDERLEGRING, VLAK	6 2	
					D8286	DIN125-A8,4-ST-A3P			
21		B	5310-12-162-2131	4	H0001	0251928	ONDERLEGRING, BORG-	6 2	
					D8286	DIN128-A8			
22		B	0000-KL-044-1296	9	H0001	0245077	ONDERLEGRING, VLAK	4 2	
23		B	5305-12-168-2229	9	D8286	DIN84-M5X12-4.8-A2P	SCHROEF, MACHINE	7 2	
24		B	5310-12-158-6218	6	H0001	0251937	ONDERLEGRING, BORG-	7 2	
					D8286	DIN6798-A5,1			

PN 002083

OPBERGKAST DEKZEIL

MOSNR 1807-0001 BLAD:

1

**YCHIE.ME**

**YCHIE.ME**

PROJECTNUMMER: 002083  
MOSNUMMER : 1807-0002

PIONIERREK

DATUM 871102  
BLAD 1 VAN 1 BLADEN

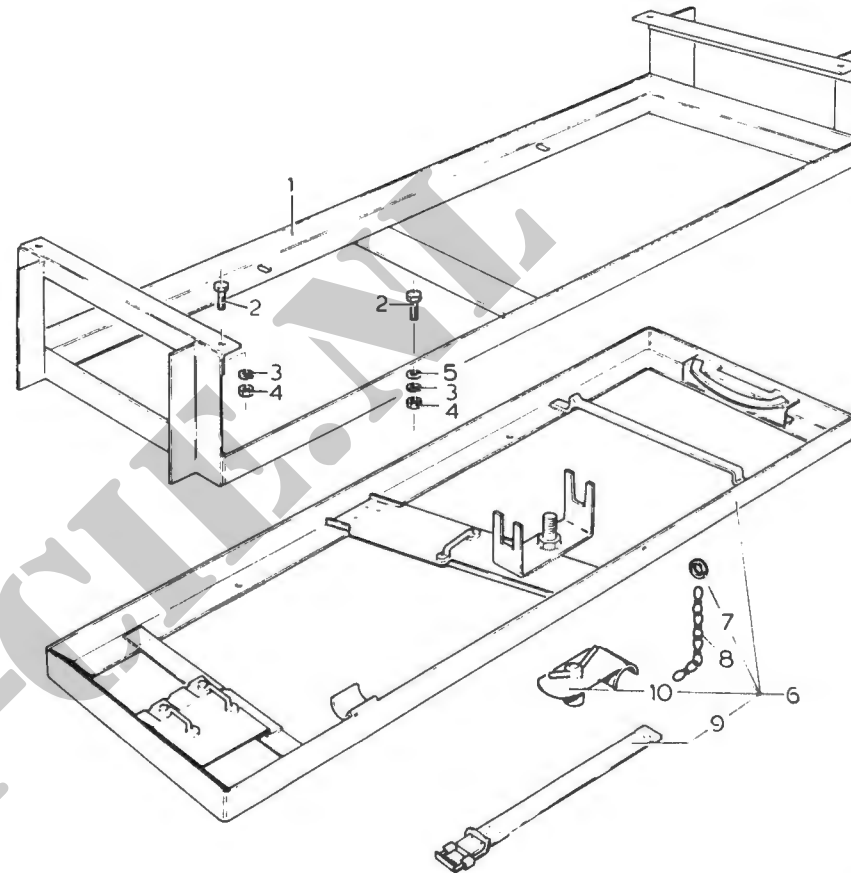
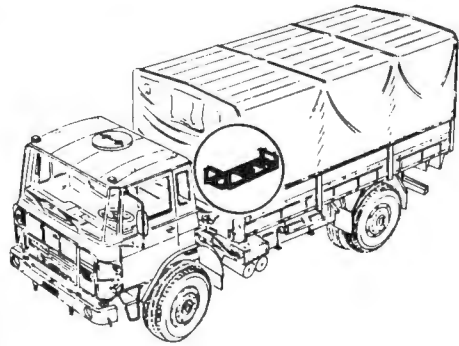

1807-0002

PN 002083

MOSNR 1807-0002

PIONIERREK

DATUM: 890905

BLAD: 1

FIGNR	N	MC	B	NSN	C	FCN	REFERENTIENUMMER (= FAN)	ARTIKELOMSCHRIJVING TOELICHTING	AANT	ECH	OPMERKINGEN
2			B	5305-12-156-4863	2	H0001	0251621	SCHROEF, ZESKANTE KO	8	2	
						D8286	DIN933-M8X20-8.8-A2P				
3			B	5310-12-162-2131	4	H0001	0251928	ONDERLEGRING, BORG-	8	2	
						D8286	DIN128-A8				
4			B	5310-12-144-6214	0	H0001	0251275	MOER, ZESKANT	8	2	
						D8286	DIN934-M8-8-A2P				
5			B	5310-12-149-4353	2	H0001	0325421	ONDERLEGRING, VLAK	4	2	
						D8286	DIN125-A8,4-ST-A3P				
6			B	2540-17-706-1562	7	H0001	0305161	REK, PIONIERSGEREEDS	1	2	R
7			B	5365-17-022-4723	9	H0001	0132910	RING, VERBINDING, RON	2	2	
											1807/0002/00006
8			B	4010-12-131-0924	9	H0001	0305261	KETTING, NIET GELAST	NB	2	MR
						D8286	DIN5686-1,6-VZK				
											1807/0002/00006
9			B	5340-17-017-3044	8			RIEM, WEBBING	2	2	
											1807/0002/00006
10			B	5340-17-049-4639	7	H0001	0305164	KLEM, RANDKLEMMING	1	2	
											1807/0002/00006

PN 002083

PIONIERREK

MOSNR 1807-0002

BLAD: 1

110

-LAATSTE BLAD-

**YCHIE.ME**

**Y-CHE.ME**

PROJECTNUMMER: 002083

MOSNUMMER : 1809-0001

BUMPER

DATUM 871102

BLAD 1 VAN 1 BLADEN

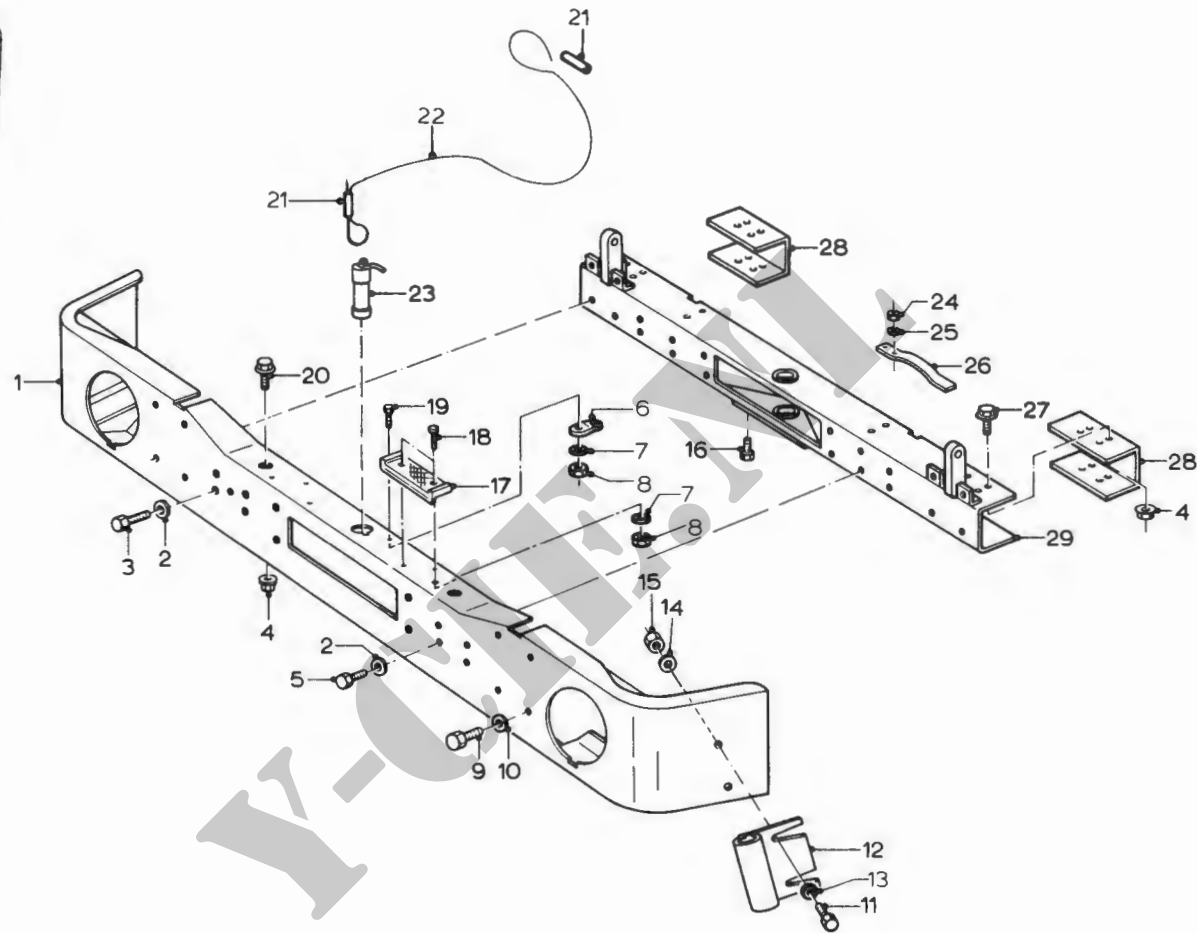
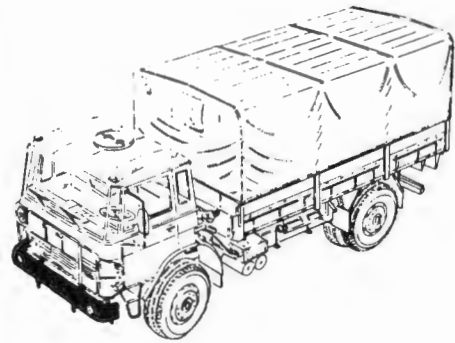

1809-0001

PN 002083

MOSNR 1809-0001

BUMPER

DATUM: 890905

BLAD: 1

FIGNR	N	MC	B	NSN	C	FCN	REFERENTIENUMMER (= FAN)	ARTIKELOMSCHRIJVING TOELICHTING	AANT	ECH	OPMERKINGEN
1			B	2540-17-103-3982	9	H0001	0391580	BUMPER, VOERTUIG	1	2	
2			B	5310-12-125-0063	0	D8286	DIN137-B5	ONDERLEGRING, VEER-	8	2	
3			B	5305-12-142-5270	0	H0001	0311211	SCHROEF, ZESKANTE KO	4	2	
						D8286	DIN961-M14X1,5X25-8.8-A3P				
4			B	5310-17-050-7984	9	H0001	0638050	MOER, KRAAG, ZESKANT	24	2	
5			B	5305-12-156-4926	0	D8286	DIN961-M14X1,5X30-8.8-A3P	SCHROEF, ZESKANTE KO	6	2	
7			B	5310-12-162-2129	2	H0001	0251927	ONDERLEGRING, BORG-	7	2	
						D8286	DIN128-A6-FST				
8			B	5310-12-156-4991	9	H0001	0251274	MOER, ZESKANT	5	2	
						D8286	DIN934-M6-8-A2P				
9			B	5305-12-178-8770	4	D8286	DIN961-M12X1,25X25-8.8-A3P	SCHROEF, ZESKANTE KO	14	2	
						H0001	0311198				
10			B	5310-12-124-0198	2	H0001	0187448	ONDERLEGRING, VEER-	12	2	
						D8286	DIN137-R12				
11			B	5305-12-171-8929	2	H0001	0311200	SCHROEF, ZESKANTE KO	4	2	
						D8286	DIN961-M12X1,25X35-8.8-A2P				
12			B	8345-17-055-1438	2	H0001	0667603	HOUDER, VLAGGESTOK	2	2	
13			B	5310-12-156-4899	5	H0001	0202950	ONDERLEGRING, VLAK	4	2	
						D8286	DIN125-B13-ST-A3P				
14			B	5310-12-162-2132	5	H0001	0251930	ONDERLEGRING, BORG-	4	2	
						D8286	DIN128-A12				
15			B	5310-12-196-2387	8	H0001	0523872	MOER, ZESKANT	4	2	
						D8286	DIN934-M12X1,25-8-A2P				
16			B	5305-12-155-6878	3	H0001	0126720	SCHROEF, ZESKANTE KO	2	2	
						D8286	DIN933-M8X16-8.8-A2P				
18			B	5305-12-171-6723	7	H0001	0319096	SCHROEF, MACHINE	4	2	
						D8286	DIN965-M6X22-4.8-H-A2P				
19			B	5305-12-146-2633	6	H0001	0126718	SCHROEF, ZESKANTE KO	1	2	
						D8286	DIN933-M6X16-8.8-A2P				
20			B	5306-17-050-8005	8	H0001	0638043	BOUT, BORST	12	2	
21			B	0000-KL-047-1903	3	H0001	0080701	KLEMSTUK	2	2	
22			B	0000-KL-047-1904	4	H0001	0080604	KABFL, TREK-	NB	2	MR
23			B	2540-17-049-7534	9	H0001	0255713	GRENDEL PEN	1	2	
24			B	5310-12-144-6214	0	H0001	0251275	MOER, ZESKANT	2	2	
						D8286	DIN934-M8-8-A2P				
25			B	5310-12-162-2131	4	H0001	0251928	ONDERLEGRING, BORG-	2	2	
						D8286	DIN128-A8				
26			B	2540-17-047-6191	6	H0001	0198721	BORGVEER, SLEEPEN	1	2	
27			B	5306-17-050-8004	7	H0001	0638044	BOUT, MACHINE	12	2	
29			B	2540-17-103-3670	5	H0001	0391396	STEUN, BUMPER, VOERTU	1	2	

PN 002083

BUMPER

MOSNR 1809-0001 BLAD: 1

**KCH.ME**

**YCHIE.ME**

PROJECTNUMMER: 002083  
MOSNUMMER : 1809-0002

BESCHERMROOSTER RADIATEUR

DATUM 871102  
BLAD 1 VAN 1 BLADEN

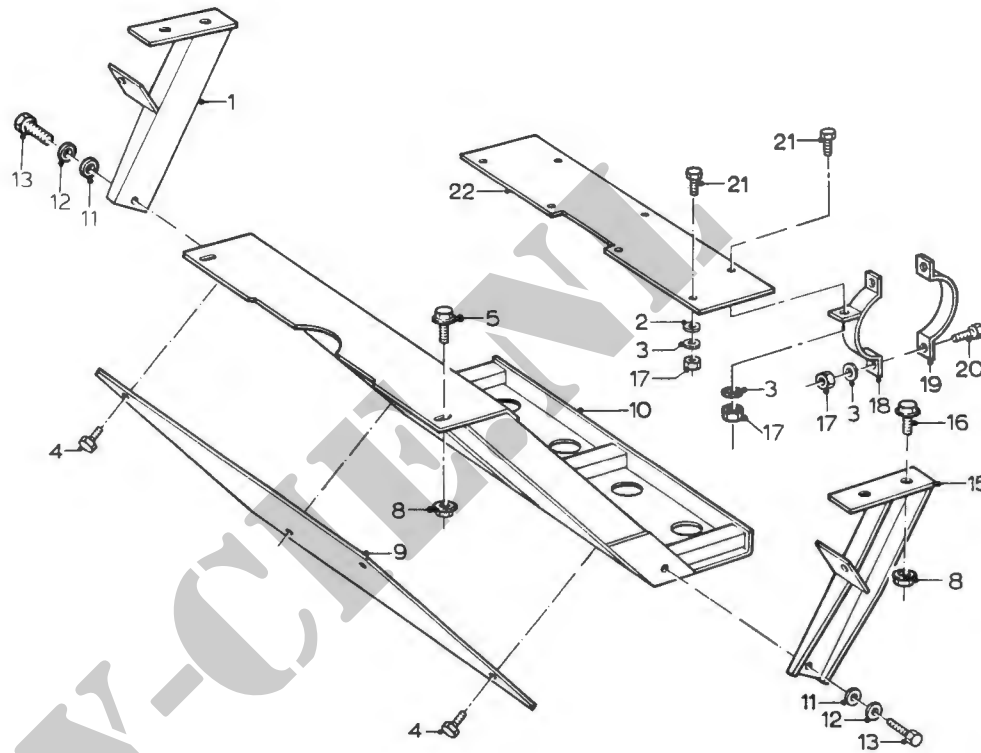
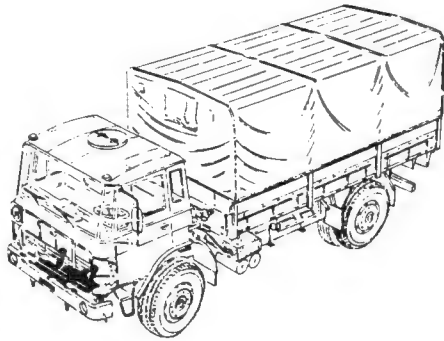

1809-0002

PN 002083

MOSNR 1809-0002

BESCHERMROOSTER RADIATEUR

DATUM: 890905

BLAD: 1

FIGNR	N	MC	B	NSN	C	FCN	REFERENTIENUMMER (= FAN)	ARTIKELOMSCHRIJVING	TOELICHTING	AANT	ECH	OPMERKINGEN
2			B	5310-12-142-0645	5	H0001	0251905	ONDERLEGRING, VLAK		4	2	
						D8286	DIN125-B8, 4-ST-A3P					
3			B	5310-12-162-2131	4	H0001	0251928	ONDERLEGRING, BORG-		9	2	
						D8286	DIN128-A8					
4			B	5306-12-317-5568	0	H0001	0268977	BOUT, MACHINE		6	2	
						D8286	DIN6921-M8X20-8.8-A2P					
5			B	5306-17-103-2456	1	H0001	0268981	BOUT, GEASSEMBLEERD		2	2	
8			B	5310-17-103-2457	2	H0001	0268986	MOER, GEASSEMBLEERD		6	2	
11			B	5310-17-003-9675	3	H0001	0577679	ONDERLEGRING, VLAK		2	2	
12			B	5310-12-162-2132	5	H0001	0251930	ONDERLEGRING, BORG-		6	2	
						D8286	DIN128-A12					
13			B	5305-12-178-8770	4	H0001	0311198	SCHROEF, ZESKANTE KO		14	2	
						D8286	DIN961-M12X1,25X25-8.8-A3P					
16			B	0000-KL-044-1297	0	H0001	0272256	BOUT, MACHINE		16	2	
17			B	5310-12-144-6214	0	H0001	0251275	MOER, ZESKANT		9	2	
						D8286	DIN934-M8-8-A2P					
18			B	5340-17-103-3917	0	H0001	0224236	BEUGEL, INSTALLATIE		1	2	
19			B	5340-17-103-3916	9	H0001	0386780	BEUGEL, INSTALLATIE		1	2	
20			B	5305-12-143-7855	0	H0001	0251622	SCHROEF, ZESKANTE KO		2	2	
						D8286	DIN933-M8X22-8.8-A2P					
21			B	5305-12-156-4962	2	H0001	0251620	SCHROEF, ZESKANTE KO		7	2	
						D8286	DIN933-M8X18-8.8-A2P					

PN 002083

BESCHERMROOSTER RADIATEUR

MOSNR 1809-0002 BLAD: 1

**YCHIE.ME**

**YCHIE.ME**

PROJECTNUMMER: 002083

MOSNUMMER : 1809-0003

# TAKKENSCHERM

DATUM 871102

BLAD 1 VAN 1 BLADEN

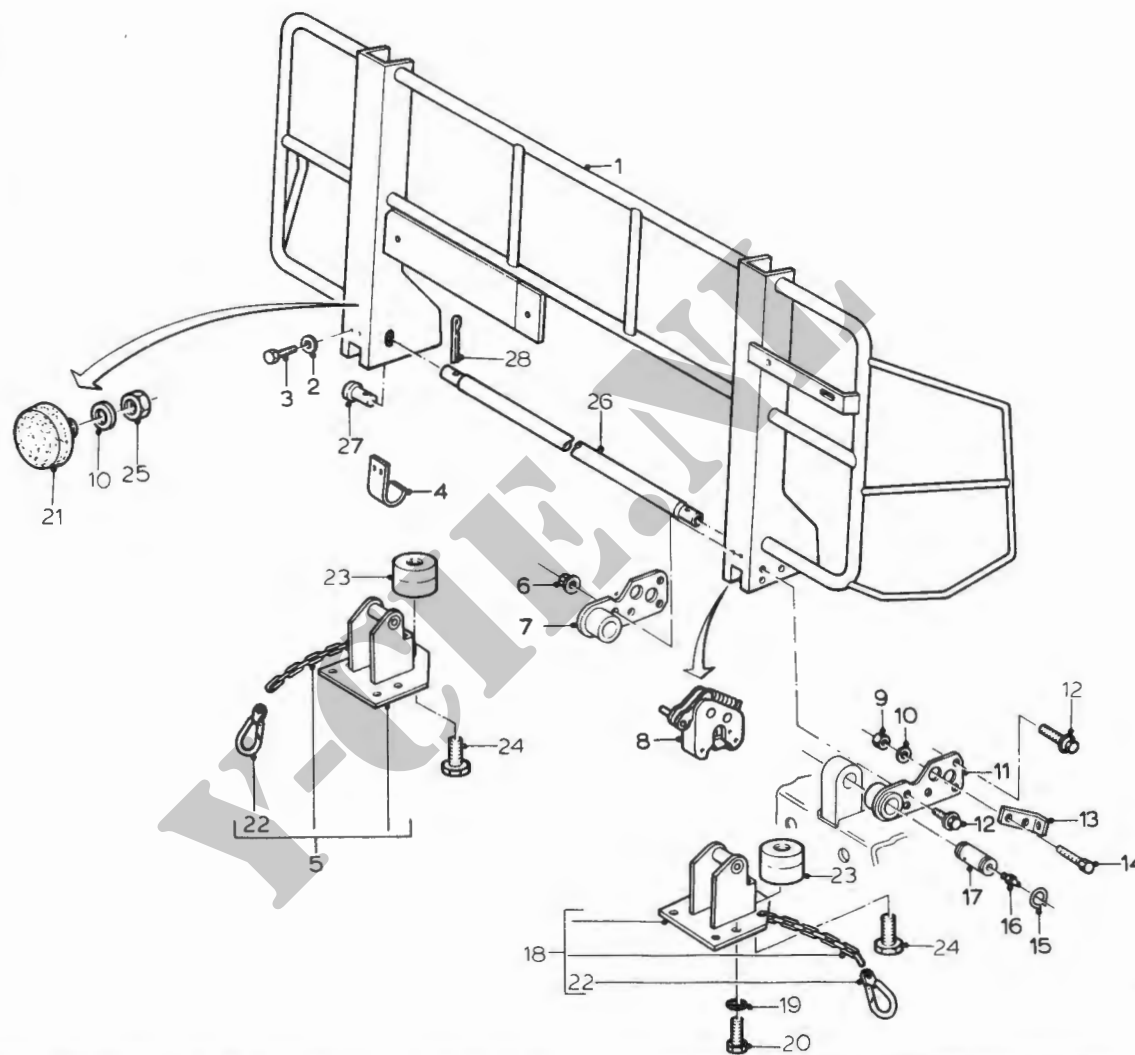
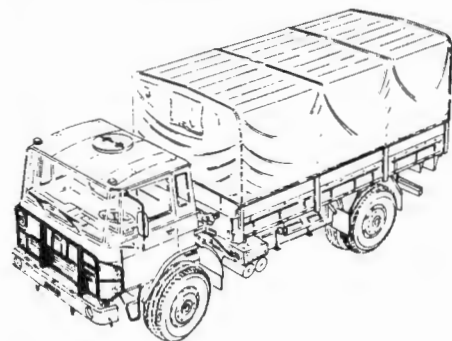

1809-0003

PN 002083

MOSNR 1809-0003

TAKKENSCHERM

DATUM: 890905

BLAD: 1

FIGNR	N	MC	B	NSN	C	FCN	REFERENTIENUMMER (= FAN)	ARTIKELOMSCHRIJVING TOELICHTING	AANT	ECH	OPMERKINGEN
1			B	2510-17-103-3905	9	H0001	0391458	GRILLE, METAAL	1	2	
2			B	5310-12-162-2129	2	H0001	0251927	ONDERLEGRING, BORG-	4	2	
3			B	5305-12-141-9839	2	H0001	0251609	SCHROEF, ZESKANTE KO	2	2	
5			B	2540-17-103-3733	2	H0001	0590526	STEUN, BUMPER, VOERTU	1	2	
15			B	5365-12-156-4436	4	H0001	0251983	RING, BORG-, VEREND	4	2	
16			B	4730-12-125-0313	8	H0001	0202864	NIPPEL, SMEER-	2	2	
17			B	5315-17-103-3983	0	H0001	0391474	PEN, GEGROEFD, ZOND	2	2	
18			B	2540-17-103-3919	1	H0001	0590525	STEUN, BUMPER, VOERTU	1	2	
23			B	0000-KL-044-0803	0	H0001	0394955	AANSLAGPROP	2	2	
24			B	5305-12-141-9870	0	H0001	0251625	SCHROEF, ZESKANTE KO	2	2	
25			B	5310-12-196-2387	8	H0001	0523872	MOER, ZESKANT	2	2	
27			B	0000-KL-044-0805	2	H0001	0329784	PEN, KOP-	2	2	
28			B	5315-12-156-4412	2	H0001	0251869	PEN, SPLIT	2	2	
						D8286	DIN933-M8X35-8.8-A2P				
						D8286	DIN934-M12X1,25-8-A2P				
						D8286	DIN1435 12X20X5X55				
						D8286	DIN94-4X45-ST				

PN 002083

TAKKENSCHERM

MOSNR 1809-0003 BLAD: 1

**YCHIE.ME**

**YCHIE.ME**

PROJECTNUMMER: 002083  
MOSNUMMER : 1810-0001

# TREKHAAK

DATUM 871102  
BLAD 1 VAN 1 BLADEN

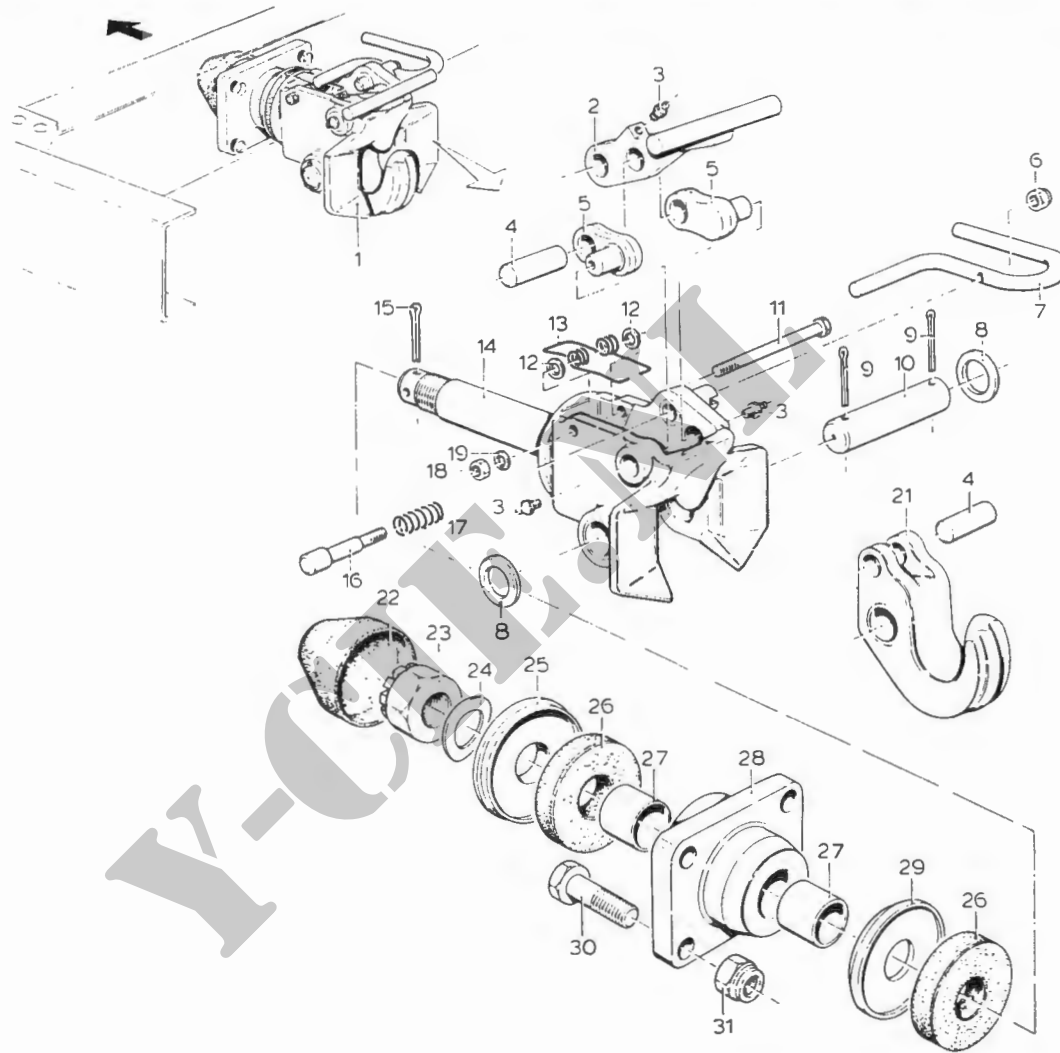
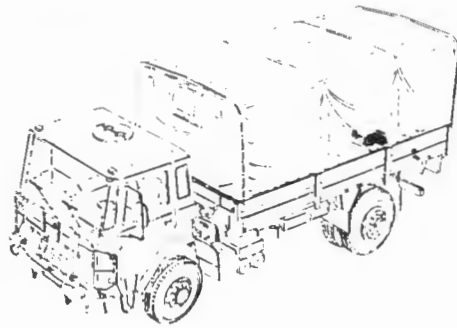

1810-0001

PN 002083

MOSNR 1810-0001

TREKHAAK

DATUM: 890905

BLAD: 1

FIGNR	N MC	B	NSN	C	FCN	REFERENTIENUMMER (= FAN)	ARTIKELOMSCHRIJVING TOELICHTING	AANT ECH	OPMERKINGEN
1		B	2540-12-164-8958	2	H0001	0621517	TREKHAAKSAMENSTEL	3	2
					D8449	6534-400-2			
3		B	4730-12-125-0313	8	H0001	0202864	NIPPEL, SMEER-	1	2
					D8286	DIN71412-AM8X1			
15		B	5315-12-196-7398	3	D8286	DIN94-8X80-ST-ZNPHR10F	PEN, SPLIT	1	2
22		B	5340-12-165-0436	6	H0001	0811220	KAP, BESCHERM-, STOF-	1	2
					D8449	6440-408-029-1			
23		B	5310-12-151-3231	4	H0001	0811200	MOER, KROON, ZESKANT	1	2
					D8286	DIN935-M45X3-6-A2P			
24		B	5310-12-177-2606	0	H0001	0811223	ONDERLEGRING, VEER-	1	2
					D8286	DIN137-B45			
25		B	5310-12-165-2287	9	H0001	0811216	ONDERLEGRING, VERZON	1	2
					D8449	6440-408-021-6			
26		B	5340-12-165-0437	7	H0001	0811217	BUFFER, RUBBER	2	2
					D8449	6440-408-023-2			
27		B	3120-12-165-0438	8	H0001	0811219	LAGER, BUS	2	2
					D8449	6440-408-026-6			
29		B	5310-12-175-8124	4	H0001	0825027	ONDERLEGRING, VERZON	1	2
					D8449	6440-408-025-6			
30		B	5305-12-142-5240	2	H0001	0311127	SCHROEF, ZESKANTE KO	4	2
					D8286	DIN960-M20X1, 5X70-8.8-A3P			
31		B	5310-12-170-7454	0	H0001	0124383	MOER, ZELFBORGEND, ZE	4	2
					D8286	DIN980-NM20X1, 5-8-A2P			

PN 002083

TREKHAAK

MOSNR 1810-0001 BLAD: 1

**YCHIE.ME**

**YCHIE.ME**

PROJECTNUMMER: 002083

MOSNUMMER : 1810-0002

SLEEPOGEN

DATUM 871102

BLAD 1 VAN 1 BLADEN

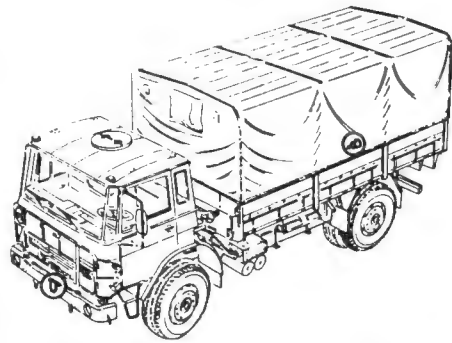

PNO02083MOS:1809-0001

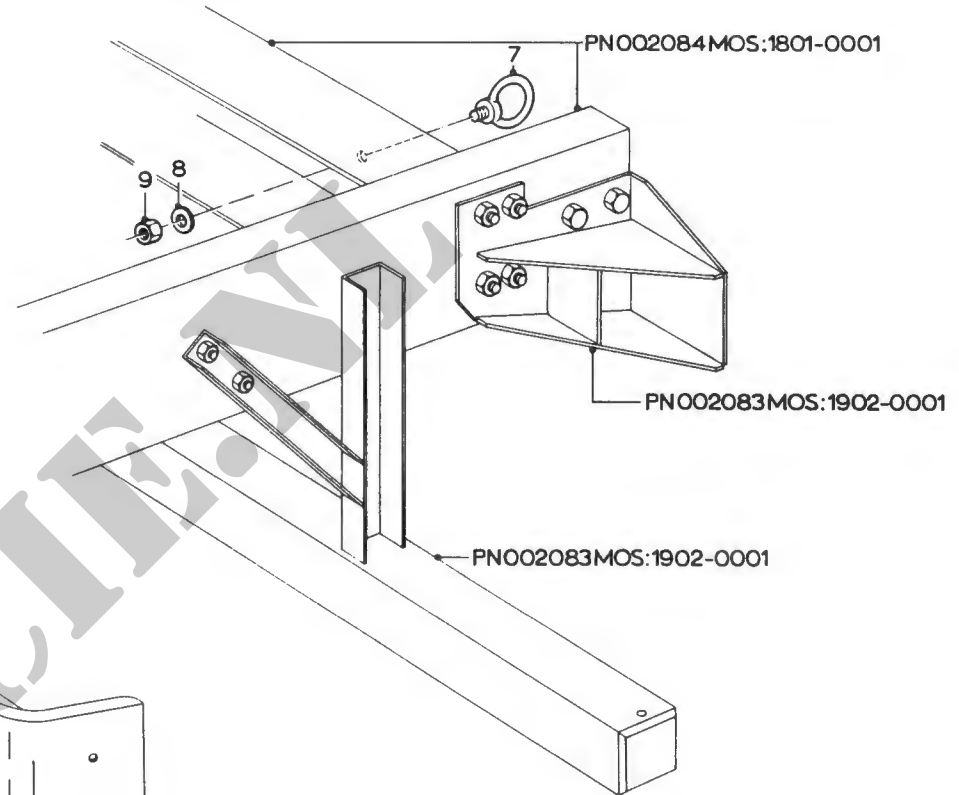
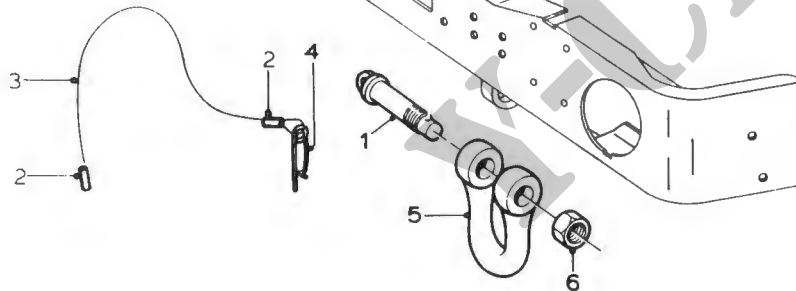

PNO02084MOS:1801-0001

PNO02083MOS:1902-0001

PNO02083MOS:1902-0001

1810-0002

PN 002083

MOSNR 1810-0002

SLEEPOGEN

DATUM: 890905 BLAD: 1

FIGNR	N	MC	B	NSN	C	FCN	REFERENTIENUMMER (= FAN)	ARTIKELOMSCHRIJVING TOELICHTING	AANT ECH	OPMERKINGEN
2			B	5365-17-022-4723	9	H0001	0132910	RING, VERBINDING, RON	4 2	
3			B	4010-17-049-7437	0	H0001	0200085	KETTING, M/BORGSPELD	2 2	1810/0002/00003
4			B	5315-17-026-3776	1	H0001	0200086	PEN, SLUIT-, MET HAAK	2 2	
5A			B	4030-12-131-4902	5	D8286	C3DIN82101-FZN600	SLUITING	2 2	1810/0002/00003
6			B	5310-12-133-8650	4	H0001	0634126	MOER, ZESKANT	2 2	
						D8286	DIN936-M27-17H			
7			B	5306-12-142-9149	6	H0001	0633731	BOUT, OOG	2 2	1810/0002/00005A
						D8286	DIN580-M20			
8			B	5310-12-166-0907	5	H0001	0251934	ONDERLEGRING, BORG-	2 2	
						D8286	DIN128-A20-A3P			
				5310-12-311-6476						DIT NSN IS VERVALLEN
9			B	5310-12-145-2658	8	H0001	0251279	MOER, ZESKANT	2 2	BIJ BESTELLING
						D8286	DIN934-M20-8-A2P			

PN 002083

SLEEPOGEN

MOSNR 1810-0002 BLAD: 1

115

-LAATSTE BLAD-

**YCHIE.ME**

**Y-CHE.ME**

PROJECTNUMMER: 002083  
MOSNUMMER : 1811-0001

RESERVEWIELDRAGER

DATUM 871102  
BLAD 1 VAN 1 BLADEN

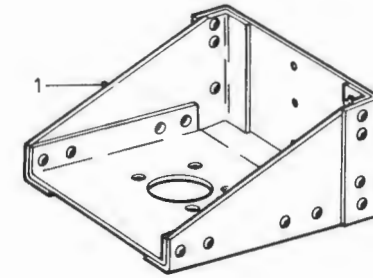
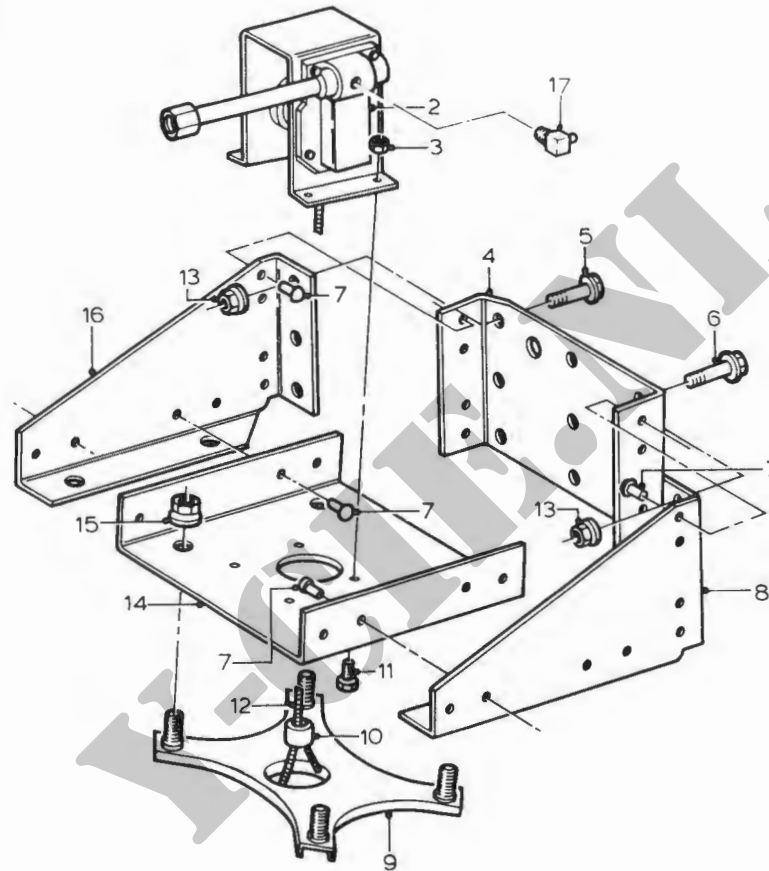
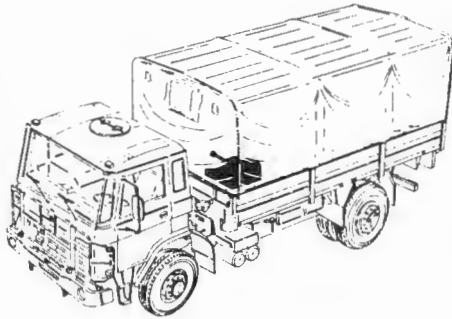

1811-0001

PN 002083

MOSNR 1811-0001

RESERVEWIELDRAGER

DATUM: 890905

BLAD: 1

FIGNR	N	MC	B	NSN	C	FCN	REFERENTIENUMMER (= FAN)	ARTIKELOMSCHRIJVING TOELICHTING	AANT	ECH	OPMERKINGEN
3			B	5310-17-915-1028	1	H0001	0268985	MOER, FLENS-	4	2	
5			B	5306-17-103-0159	3	H0001	0294485	BOUT, BORST	4	2	
6			B	5306-17-050-7993	7	H0001	0638048	BOUT, MACHINE	3	2	
10			B	0000-KL-041-0923	7	H0001	0221275	KLEMSTUK	1	2	
11			B	5306-12-317-5568	0	H0001	0268977	BOUT, MACHINE	4	2	
						D8286	DIN6921-M8X20-8.8-A2P				
12			B	0000-KL-041-0924	8	H0001	0293054	KABEL TREK	1	2	
13			B	5310-17-050-5044	6	H0001	0638051	MOER, KRAAG, ZESKANT	7	2	
15			B	5310-17-054-3357	6	H0001	0652575	MOER, GEASSEMBLEERD	4	2	
17			B	4730-12-124-1359	8	D8286	DIN71412-CM6	NIPPEL, SMEER-	1	2	

PN 002083

RESERVEWIELDRAGER

MOSNR 1811-0001 BLAD: 1

116

-LAATSTE BLAD-

**YCHIE.ME**

**Y-CHE.ME**

PROJECTNUMMER: 002083  
MOSNUMMER : 1902-0001

STOOTBALK + BUFFERS

DATUM 871102  
BLAD 1 VAN 1 BLADEN

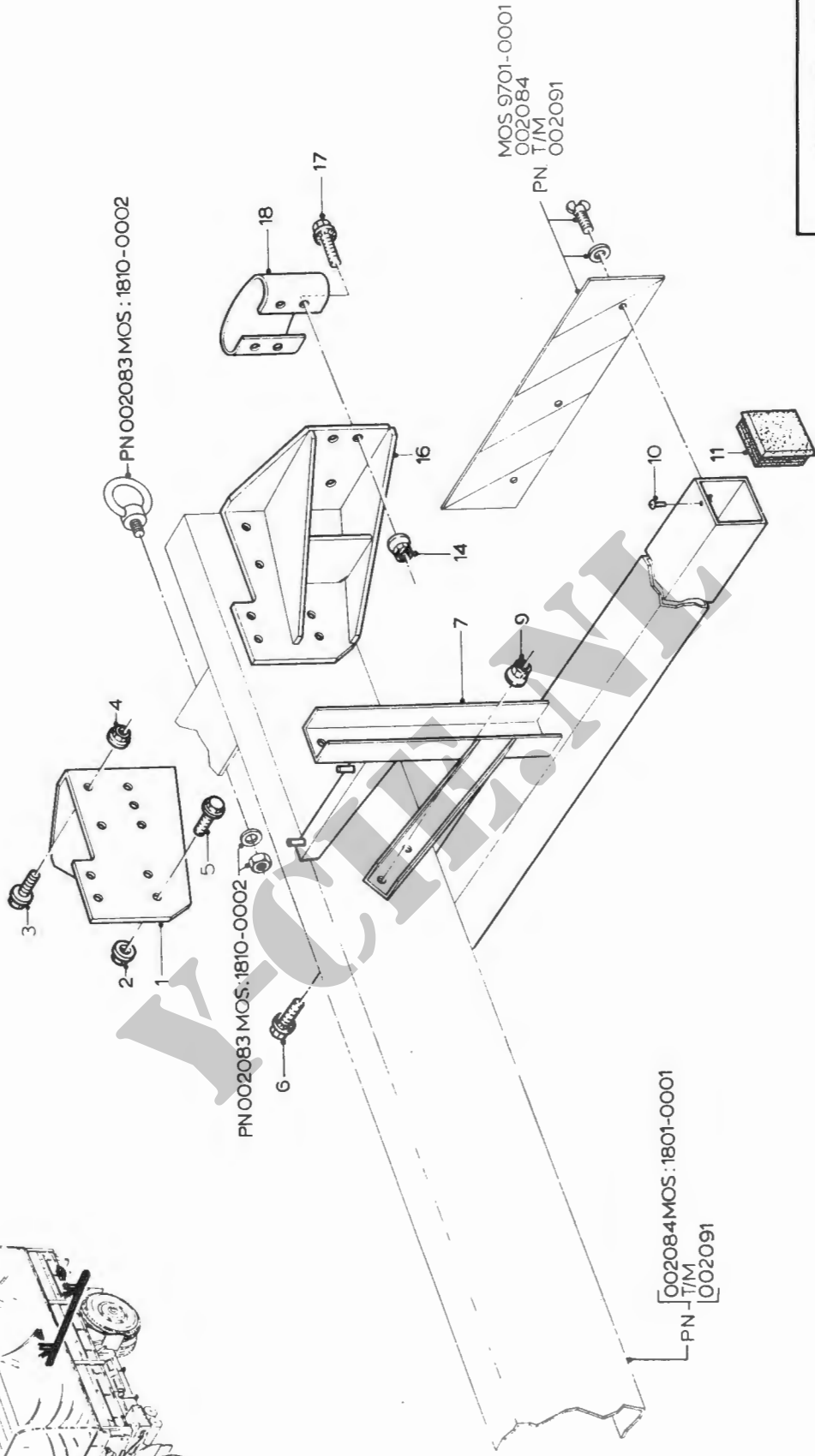
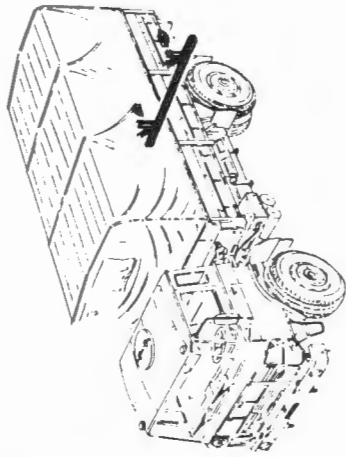

1902-0001

PN 002083

MOSNR 1902-0001

STOOTBALK+BUFFERS

DATUM: 890905 BLAD: 1

FIGNR	N	MC	B	NSN	C	FCN	REFRENTIFNUMMER (= FAN)	ARTIKEI OMSCHRIJVING TOELICHTING	AANT ECH	OPMERKINGEN
2			B	5310-17-050-5044	6	H0001	0638051	MOER, KRAAG, ZESKANT	8	2
3			B	5306-17-050-8004	7	H0001	0638044	BOUT, MACHINE	10	2
4			B	5310-17-050-7984	9	H0001	0638050	MOER, KRAAG, ZESKANT	10	2
5			B	5306-17-103-0159	3	H0001	0294485	BOUT, BORST	8	2
6			B	5306-17-102-9952	5	H0001	0268978	BOUT, GEASSEMBLEERD	8	2
7			B	2540-17-103-3735	4	H0001	0395924	BUMPER, VOERTUIG	1	2
9			B	0000-KL-040-5698	7	H0001	0645165	MOER, FLENS-METR. GLA	8	2
10			B	5305-12-142-5718	7	D8286	DIN7981-ST4, 2X13-C-H-A3P	SCHROEF, ZELFSCHROEF	4	2
11			B	5340-17-049-9830	6	H0001	0738931	BUFFER, KUNSTSTOF	2	2
14			B	5310-17-103-2457	2	H0001	0268986	MOER, GEASSEMBLEERD	8	2
17			B	5306-17-103-2456	1	H0001	0268981	BOUT, GEASSEMBLEERD	8	2

PN 002083

STOOTBALK+BUFFERS

MOSNR 1902-0001 BLAD: 1

117

-LAATSTE BLAD-

**YCHIE.ME**

**KCH.ME**

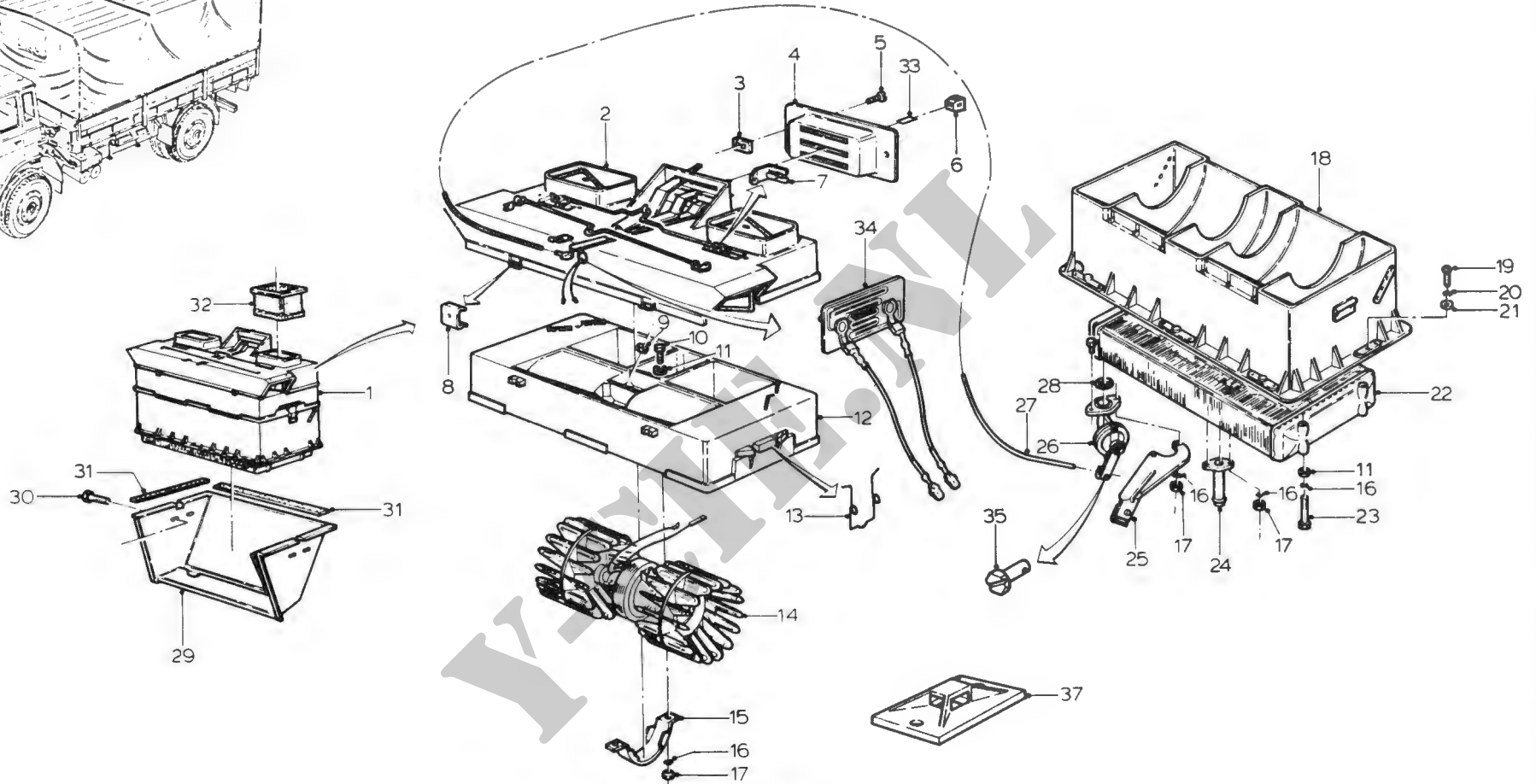
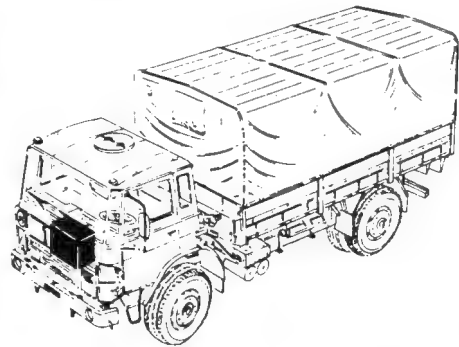

POS. NRS. 25 en 27 vormen REP SET POS 36

2501-0001

PN 002083

MOSNR 2501-0001

VERWARMINGSKACHEL

DATUM: 890905 BLAD: 1

FIGNR	N MC B	NSN	C FCN	REFERENTIENUMMER (= FAN)	ARTIKELOMSCHRIJVING TOELICHTING	AANT ECH	OPMERKINGEN
1	B	2540-14-354-1485	0		KACHEL, VOERTUIG	1 2	DR
3	B	5310-12-172-8767	6	H0001 0175153	MUTTER	2 2	
5	B	5305-12-142-5529	5	H0001 0123941	SCHROEF, MACHINE	3 2	
6	B	2540-14-354-6887	0	D8286 DIN7985-M4X10-4.8-H-A2P	CHAUFFAGE, SOUS-ASSE	3 2	
16	B	5310-12-158-6218	6	H0001 0173959	ONDFRLEGRING, BORG-	2 2	
20	B	5310-12-124-0890	1	F2111 881556	ONDERLEGRING, BORG-	8 2	
21	B	5310-12-142-0644	4	H0001 0251937	ONDERLEGRING, VLAK	8 2	
22	B	4120-14-351-3947	5	D8286 DIN6798-A5, 1	RADIATEUR, AERO-REFR	1 2	
23	B	5305-12-196-6640	4	H0001 0251938	SCHROEF, ZESKANTE KO	3 2	
24	B	4710-14-353-0687	3	D8286 DIN6798-A6, 4	PYPSAMENSTEL, METAAL	1 2	
25	B	5340-14-353-0688	4	H0001 0175170	ANKERSTRIP	1 2	
26	B	4810-14-354-1479	4	D8286 DIN931-M5X60-8.8-A2P	AFSLUITER, STOP-, MEM	1 2	
27	B	5360-17-910-6370	3	H0001 0259395	VEER, TREK-, SCHROEFL	1 2	
28	B	5330-14-351-3948	6	F2111 T01001	GASKETSTEL	2 2	
30	B	5306-17-910-8562	6	H0001 0259396	BOUT, FLENS-	4 2	
31	B	9330-17-049-8303	8	F2111 Z201	KUNSTSTOFSTROOK, ZEL	NB 2	MR
32	B	4720-17-050-1965	7	H0001 0513732	SLANG, CIRCULATIELUC	2 2	
33	B	5340-17-054-0255	6	H0001 0259394	KLEMPLAAT	1 2	
35	B	4730-17-911-0138	9	F2111 T01105	KLEMMOER	1 2	
				H0001 0177449			
				H0001 0170511			
				H0001 0509147			
				F2111 018125H			
				H0001 0107696			
				F2111 018126U			

PN 002083

VERWARMINGSKACHEL

MOSNR 2501-0001 BLAD: 1

118

-LAATSTE BLAD-

Y-CHE.ME